3.5PC

Aluminium gear pumps

Technical Catalogue

E0.114.0416.02.00IM03



GEAR PUMPS

SALAMI gear pumps are available with displacements from 1.4 cm³/rev to 99 cm³/rev (from 0.09 cu.in/rev to 6.03 cu.in/rev).

Multiple pumps can always be realized combining stages taken from different or same series.

Several options of shafts, flanges and ports as for European, German and American standards are available for all the pumps.

SALAMI gear pumps offer:

- High volumetric efficiency thanks to an innovative design and an accurate control of machining tolerances.
- Axial compensation achieved by the use of floating bushes that allow high volumetric efficiency throughout the working pressure range.
- DU bearings to ensure high pressure capability.
- 12 teeth integral gear and shaft.
- Aluminium body.
- Cast iron flange and cover.
- Double shaft seals.
- Nitrile seals as standard and Viton seals in high temperature applications.
- All pumps are hydraulically tested after assembly to ensure the highest standard performance.
- Gear pumps are ideal for mobile equipment including: snow plows, light duty equipment, farm vehicles, town trucks, cherry pickers, lift gates, utility vehicles, aerial devices, hoists, spreaders, fan drive.
- Also available Bidirectional rotation.

TECHNICAL DATA

- Pump inlet pressure (absolute pressure)	0.8 to 1.5 bar (11.6 to 21.7 psi)
- Minimum operating fluid viscosity	12 mm ² / sec
- Max starting viscosity	800 mm ² / sec
- Suggested fluid viscosity range	17 - 65 mm ² / sec
- Fluid operating temperature range	-20 to 80 °C
- Fluid operating temperature range with FPM seals (Viton)	-15 to 110°C
- Fluid operating temperature range with HNBR seals*	-30 to 110°C
- Hydraulic fluid	mineral oil

*Available on request.

Important:

in case of assembling of pumps without shaft seals (eg. B4 - B5....), you have to keep the value of min. suction pressure (0.8 bar (abs)) in the vane between pump and coupling too.
Lower pressure can lead to suction of oil through the front flange (seat of the shaft without seal); this can damage seriously the pump.

DEFINITION OF PRESSURES

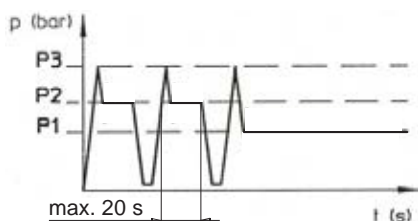

- P3 = Peak pressure
- P2 = Intermittent operating pressure (1/3 of working time)
- P1 = Continuous operating pressure

EO.100.0416.02.001M00



DRIVE SHAFTS

Radial and axial loads on the shafts must be avoided since they reduce the life of the unit. In order to avoid misalignment during the assembly with the primary engine, a connection with “Oldham” coupling (or coupling having convex toothed hub) is recommended.

ROTATION

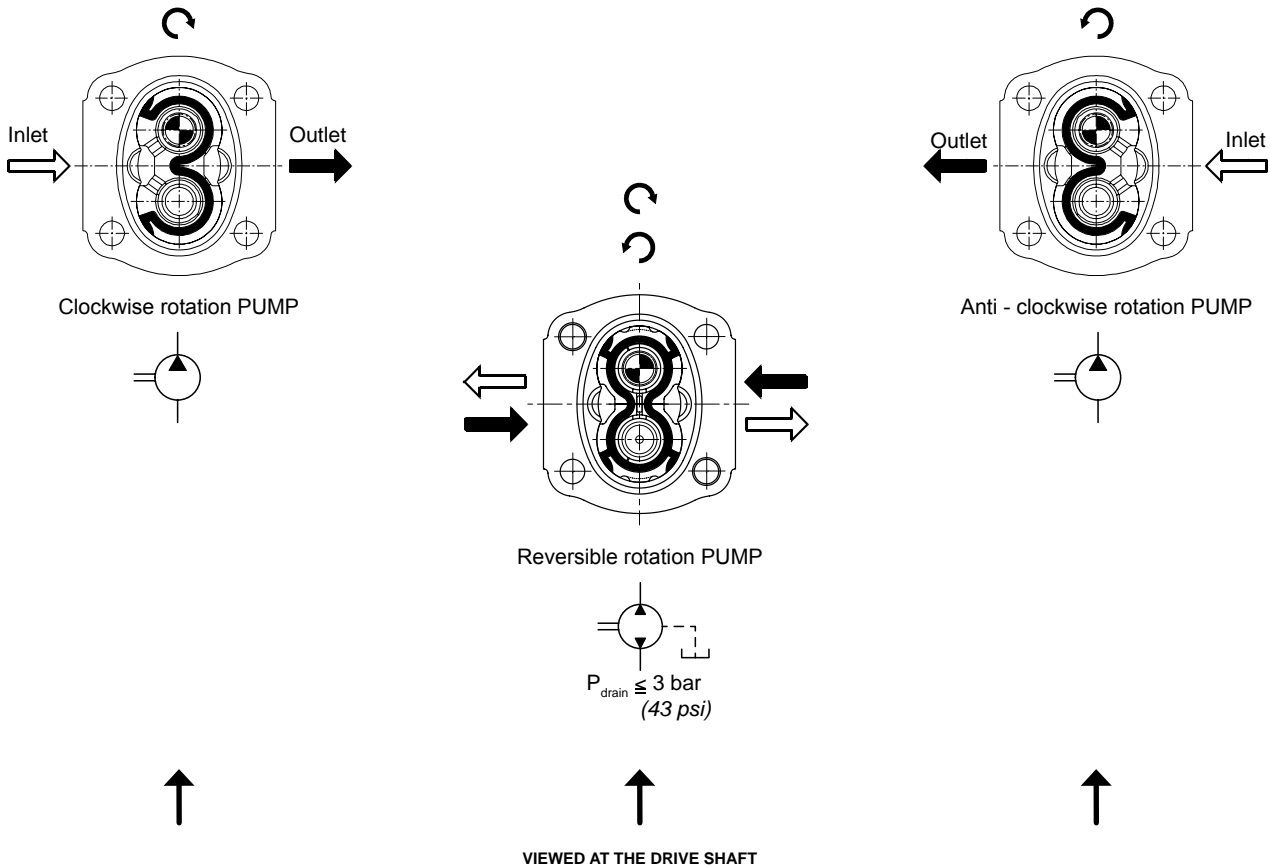

HYDRAULIC PIPE LINE

To ensure favorable suction conditions it is important to keep pressure drop in suction pipe line to a minimum value (see TECHNICAL DATA). To calculate hydraulic pipe line size, the designer can use; as an approximate guide, the following fluid speed figures:

From 1 to 2 m/sec on suction pipe line
From 6 to 10 m/sec on pressure pipe line

From 3.28 to 6.36 ft/sec on suction pipe line
From 19.7 to 32.8 ft/sec on pressure pipe line

The lowest fluid speed values in pipe lines is recommended when the operating temperature range is high and/or for continuous duty.

The highest value is recommended when the temperature difference is low and/or for intermittent duty.

When tandem pumps are supplied by 2 different reservoirs with 2 different fluids it is necessary to specify “AS” version.

E0.100.0416.02.00IM00



FILTRATION INDEX RECOMMENDED

Working pressure	>200 bar/2900 psi	<200 bar/2900 psi
Contamination class NAS 1638	9	10
Contamination class ISO 4406	19/18/15	20/19/16
Achieved with filter $\beta_x=75$	15 μm	25 μm

FIRE RESISTENT FLUID

Type	Description	Max pressure	Max speed (rpm)	Temperature
HFB	Oil emulsion with 40% water	130 bar/1880 psi	2500	3°C+65°C
HFC	Water glycol	180 bar/2600 psi	1500	-20°C+65°C
HFD	Phosphate esters		1750	-10°C+80°C

COMMON FORMULAS FOR PUMPS

$$C = \text{Input torque} = \frac{q \cdot \Delta p}{62.8 \cdot \eta_m} \text{ (Nm)}$$

$$P = \text{Input power} = \frac{q \cdot n \cdot \Delta p \cdot 10^{-3}}{600 \eta_m} \text{ (kW)}$$

$$Q = \text{Outlet flow} = \frac{q \cdot n \cdot \eta_v}{1000} \text{ (l/min)}$$

LEGENDA

Δp = Working pressure (bar)

q = Displacement (cm^3/rev)

n = Speed (min^{-1})

η_m = Mechanical eff. (0.92)

η_v = Volumetric eff. (0.95)

IDENTIFICATION LABEL

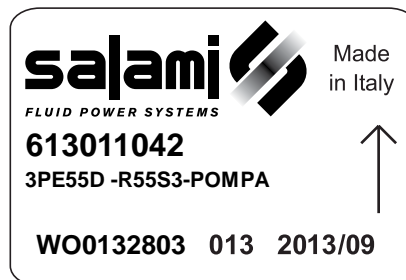

Salami part number
Product short description

Rotation sense

Product code (for Salami management)

Month and year of made
Number of assembling

EO.100.0416.02.001M00



WORKING CONDITIONS

	Displacement		Working pressure P ^{1**}		Intermittent pressure P ²		Peak pressure P ³		Max. speed	Min. speed
	cm ³ /rev	cu.in/rev	bar	psi	bar	psi	bar	psi		
GROUP 1.5 - E SERIES									min ⁻¹	
1.5PE - 1.4	1.4	0.09	250	3625	270	3915	290	4205	5000	700
1.5PE - 2.1	2.1	0.13	250	3625	270	3915	290	4205	5000	700
1.5PE - 2.8	2.8	0.17	250	3625	270	3915	290	4205	4500	700
1.5PE - 3.5	3.5	0.21	250	3625	270	3915	290	4205	4500	700
1.5PE - 4.1	4.1	0.25	250	3625	270	3915	290	4205	4000	700
1.5PE - 5.2	5.2	0.32	230	3335	250	3625	270	3915	4000	700
1.5PE - 6.2	6.2	0.38	230	3335	250	3625	270	3915	3600	600
1.5PE - 7.6	7.6	0.46	200	2900	220	3190	250	3625	3300	600
1.5PE - 9.3	9.3	0.57	180	2610	200	2900	240	3480	3000	600
1.5PE - 11	11	0.67	170	2465	190	2755	220	3190	3000	600

	Displacement		Working pressure P ^{1**}		Intermittent pressure P ²		Peak pressure P ³		Max. speed	Min. speed
	cm ³ /rev	cu.in/rev	bar	psi	bar	psi	bar	psi		
GROUP 2 - E SERIES									min ⁻¹	
2PE - 3.2*	3.2	0.19	250	3625	280	4060	300	4350	4000	600
2PE - 3.9*	3.9	0.24	250	3625	280	4060	300	4350	4000	600
2PE - 4.5	4.6	0.27	250	3625	280	4060	300	4350	4000	600
2PE - 6.5	6.5	0.4	250	3625	280	4060	300	4350	4000	600
2PE - 8.3	8.2	0.5	250	3625	280	4060	300	4350	3500	500
2PE - 10.5	10.6	0.65	250	3625	280	4060	300	4350	3500	500
2PE - 11.3	11.5	0.68	250	3625	280	4060	300	4350	3500	500
2PE - 12.5	12.7	0.77	250	3625	280	4060	300	4350	3500	500
2PE - 13.8	13.8	0.84	250	3625	280	4060	300	4350	3500	500
2PE - 16	16.6	1.01	250	3625	280	4060	300	4350	3000	400
2PE - 19	19.4	1.15	220	3140	240	3480	260	3750	3000	400
2PE - 22.5	22.9	1.37	200	2900	220	3140	240	3480	2750	400
2PE - 26	25.8	1.58	180	2610	200	2900	220	3190	2500	400

*Available only as rear pump

	Displacement		Working pressure P ^{1**}		Intermittent pressure P ²		Peak pressure P ³		Max. speed	Min. speed
	cm ³ /rev	cu.in/rev	bar	psi	bar	psi	bar	psi		
GROUP 2.5 - B SERIES									min ⁻¹	
2.5PB - 5.5*	5.97	0.36	250	3625	280	4060	300	4350	3000	600
2.5PB - 8.3*	8.29	0.50	250	3625	280	4060	300	4350	3000	600
2.5PB - 11.5*	11.76	0.72	250	3625	280	4060	300	4350	3000	600
2.5PB - 13.8*	14.07	0.86	250	3625	280	4060	300	4350	3000	600
2.5PB - 16	16	0.97	250	3625	280	4060	300	4350	3000	600
2.5PB - 19	19.3	1.17	250	3625	280	4060	300	4350	3000	600
2.5PB - 22	22.2	1.35	250	3625	280	4060	300	4350	3000	500
2.5PB - 25	25.2	1.53	250	3625	280	4060	300	4350	3000	500
2.5PB - 28	27.6	1.68	250	3625	280	4060	300	4350	3000	500
2.5PB - 32	32.4	1.97	230	3330	250	3625	260	3750	3000	500
2.5PB - 38	38.1	2.32	200	2900	220	3140	240	3480	2750	400
2.5PB - 44	44.2	2.69	170	2465	190	2755	210	3040	2500	400

*Available only as rear pump. Displacements 11.5-13.8 are available as single pump only with drive shaft “55”.



	Displacement		Working pressure P ^{1**}		Intermittent pressure P ²		Peak pressure P ³		Max. speed	Min. speed
	cm ³ /rev	cu.in/rev	bar	psi	bar	psi	bar	psi		
GROUP 3 - E SERIES									min ⁻¹	
3PE - 21*	20.6	1.26	250	3625	280	4060	300	4350	3000	600
3PE - 27	27	1.65	250	3625	280	4060	300	4350	3000	600
3PE - 33	33.5	2.04	250	3625	280	4060	300	4350	3000	600
3PE - 38	38.7	2.36	250	3625	280	4060	300	4350	2750	500
3PE - 46	46.9	2.86	250	3625	270	3915	280	4060	2750	500
3PE - 55	54.1	3.3	220	3140	240	3480	250	3625	2500	400
3PE - 65	63.1	3.85	200	2900	220	3140	240	3480	2500	400
3PE - 75*	73.4	4.48	180	2610	200	2900	220	3140	2500	400

*Displacements 21 and 75 are special release, please contact sales department.

	Displacement		Working pressure P ^{1**}		Intermittent pressure P ²		Peak pressure P ³		Max. speed	Min. speed
	cm ³ /rev	cu.in/rev	bar	psi	bar	psi	bar	psi		
GROUP 3.5 - C SERIES									min ⁻¹	
3.5PC - 55	54.8	3.34	250	3625	280	4060	300	4350	2750	400
3.5PC - 64	63.2	3.85	250	3625	280	4060	300	4350	2750	350
3.5PC - 75	74.7	4.55	230	3330	250	3625	280	4060	2500	300
3.5PC - 87	88	5.36	210	3040	230	3330	260	3750	2250	300
3.5PC - 98*	99	6.03	200	2900	220	3140	250	3625	2000	300

*Displacement 98 are special release, please contact sales department.

**For working conditions, using exclusively pressure P¹, the value of max. speed must be reduced of 10%.

For bidirectional pump the max pressure has to be reduced of 10%.

The max pressure is referred to pumps with flanged ports, using the threaded ports the pump life could be reduced.



ROTATION CHANGING INSTRUCTIONS FOR UNITS

Before starting, be sure that the pump is cleaned externally as well as the working area to avoid that particles dangerous for pump working can find their way into the pump. Pump represented is a clockwise rotation pump.

To obtain an anti_clockwise rotation read carefully the following instructions.

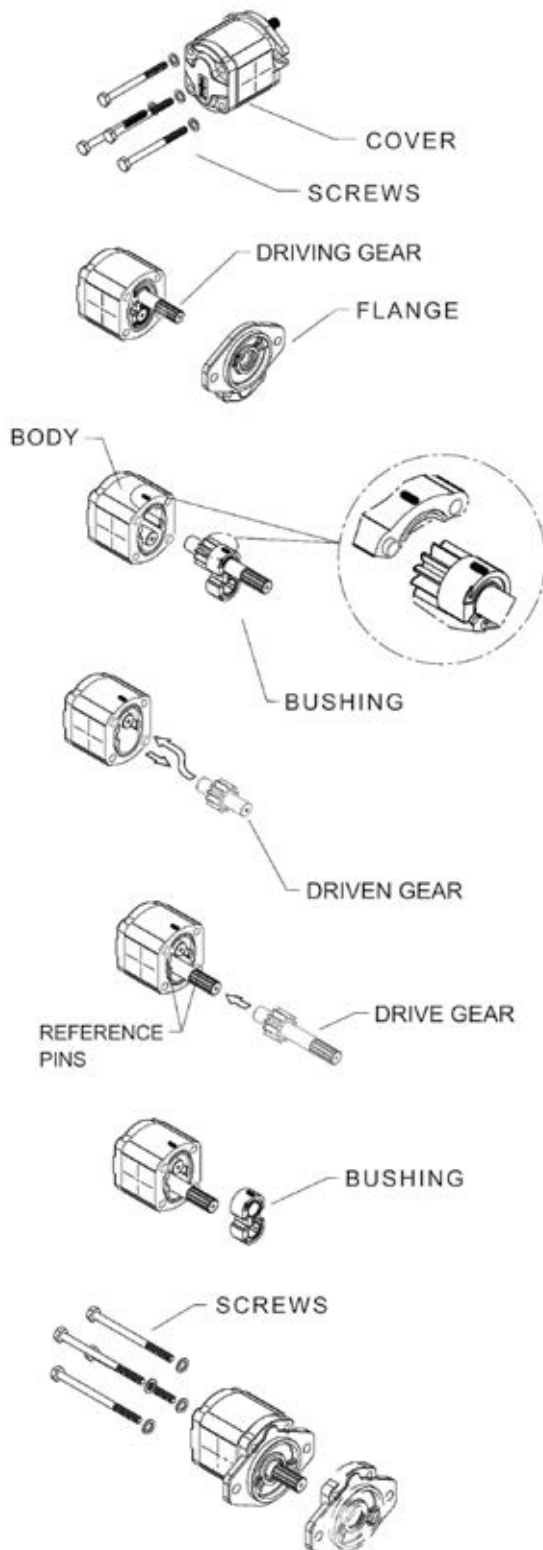

- 1 - Loosen and fully unscrew the screws.
- 2 - Lay the pump on the working area in order to have the mounting flange turned upside.
- 3 - Coat the shaft extension with grease to avoid damaging the shaft seal.
- 4 - Remove the flange and lay it on the working area; verify that the seal is correctly located in the body seat.

- 1 - Mark the position of the bushing and eventually the thrust plate, relative to the body.
- 2 - Remove the bushing, thrust plate and the driving gear taking care to avoid driven gear axial shifts.

- 1 - Draw out the driven gear from its housing, taking care to avoid rear cover axial shifts.
- 2 - Re-locate the driven gear in the position previously occupied by the driving gear.

- 1 - Re-locate the driving gear in the position previously occupied by the driven gear.

- 1 - Replace the bushing and thrust plate taking care that:
 - marks are located as on the picture
 - surface containing the seal is visible
 - seal and its protection are correctly located

- 1 - Clean body and mounting flange refaced surfaces.
- 2 - Verify that the two plugs are located in the body.
- 3 - Refit the mounting flange, turned 180° from its original position.
- 4 - Replace the clamp bolts and tighten crosswise evenly to a torque you will find at page 8.
- Check that the shaft rotates freely.
- 6 - Mark on the flange the new direction of rotation.



INDEX

Shafts And Flanges Combination	109
Assembling Dimensions	110
Configuration 49P4 (4PB).....	111
Flanged And Threaded Ports.....	112
Drive Shafts	112
Mounting Flanges	113
Outrigger Bearing	114
Multiple Gear Pumps Assembling Dimensions.....	115
3.5PC Combination With 3PE	116
3.5PC Combination With 2PE	117
Performance Curves.....	118
How To Order Single Pumps	120
How To Order Multiple Pumps.....	121

Final revised edition-April 2016





The data in this catalogue refers to the standard product.

The policy of Salami S.p.A. consists of a continuous improvement of its products. It reserves the right to change the specifications of the different products whenever necessary and without giving prior information.

If any doubts, please get in touch with our sales department.

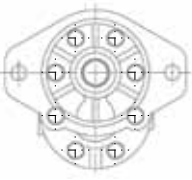
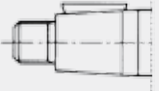

SHAFTS AND FLANGES COMBINATION

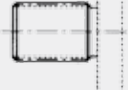
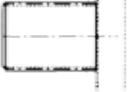
3.5PC			
	CODE P3 European standard Ø60.3	CODE P4 European standard Ø63.5	CODE S3 SAE B 2 Bolts Ø101.6
 CODE 48 - Tapered 1:8 Ø24.64	48P3		
 CODE 49 - Tapered 1:8 Ø31.75		49P4	
 CODE 55 - SAE B Splined 13T			55S3
 CODE 56 - SAE BB Splined 15T			56S3

Note: other versions available, see shafts and flanges information.

E0:114.0416:02.001M03

Displacements up to 6.03 cu.in./rev
Pressure up to 4350 psi



GEAR PUMPS

Displacements up to 99 cm³/rev
Pressure up to 300 bar

ASSEMBLING DIMENSIONS

Type		55	64	75	87	98*
Displacement	cm ³ /rev	54.8	63.2	74.7	88	99
	cu.in./rev	3.34	3.85	4.55	5.36	6.03
Dimension A	mm	165	177	184	192	197
	in	6.49	6.96	7.24	7.55	7.75
Dimension C	mm	80	86	89.5	93.5	96
	in	3.14	3.38	3.52	3.68	3.77
Weight	kg	10.7	11.4	11.9	12.5	12.8
	lbs	23.54	25.08	26.18	27.55	28.21

*Available for quantity.

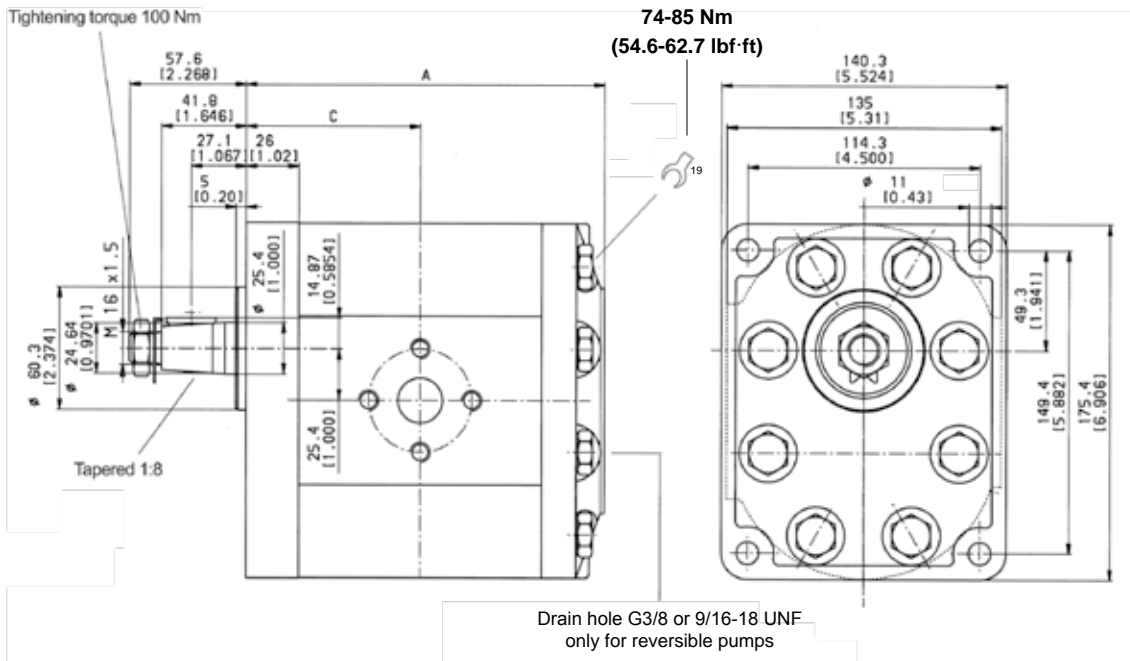

E0.114.0416.02.00IM03



Displacements up to 6.03 cu.in./rev
Pressure up to 4350 psi



Displacements up to 99 cm³/rev
Pressure up to 300 bar

**CONFIGURATION 49P4
(4PB)**

Type		75	87	98*
Displacement	cm ³ /rev	74.7	88	99
	cu.in./rev	4.55	5.36	6.03
Dimension A	mm	184	192	197
	in	7.24	7.55	7.75
Dimension C	mm	89.5	93.5	96
	in	3.52	3.68	3.77
Weight	kg	12.5	13	14
	lbs	27.5	28.6	30.8

*Available for quantity.

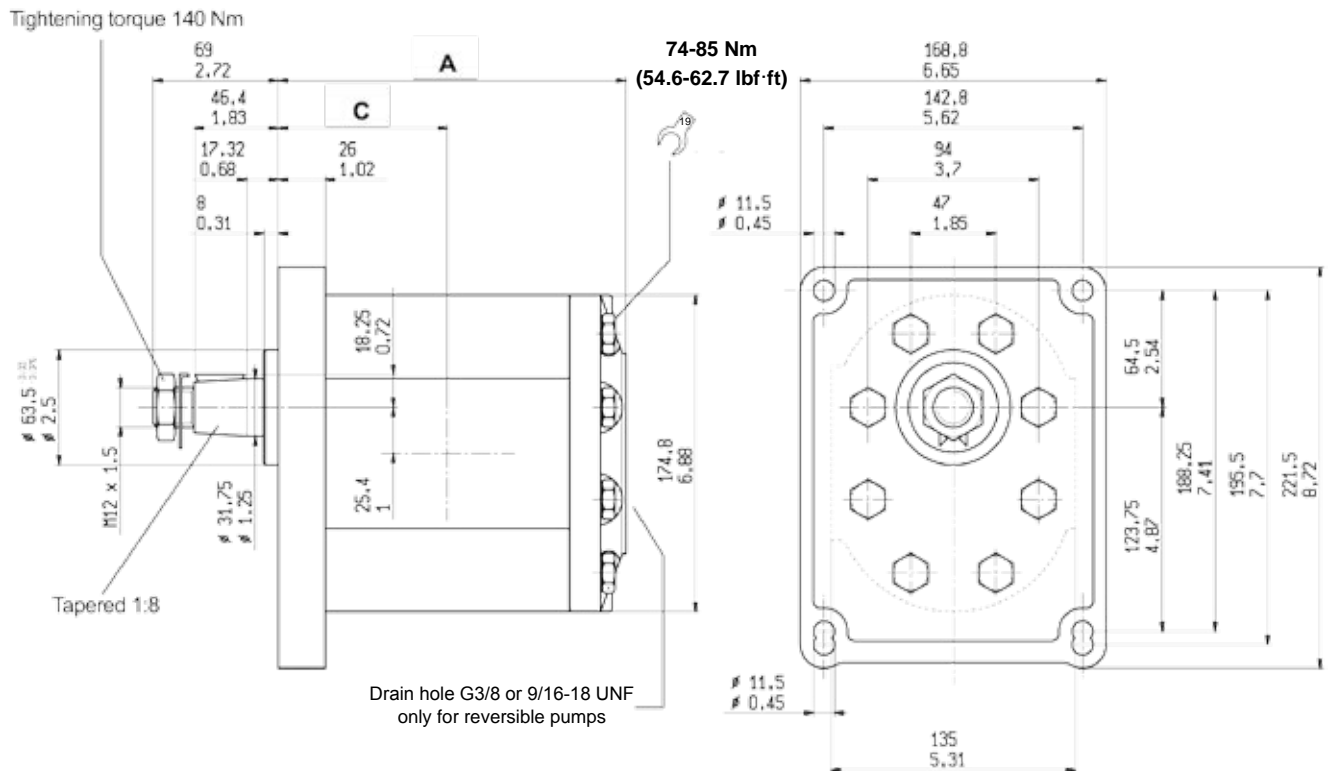

EO:114.0416:02.001M03



FLANGED AND THREADED PORTS

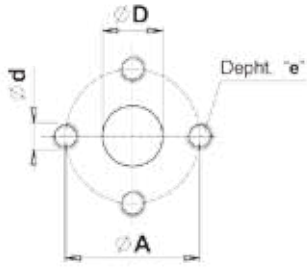

code P

Flanged ports
european standard



TYPE	INLET				OUTLET			
	Ø A	Ø D	d	e	A	Ø D	d	e
55	51 (2.01")	27 (1.06")	M10	16 (0.63")	51 (2.01")	22 (0.87")	M10	16 (0.63")
64	62 (2.44")	33 (1.30")	M12	22 (0.86")				
From 75 to 98	72 (2.85")	38 (1.50")	M12					



BI-DIRECTIONAL PUMPS Special version available on request.

For version 49P4:

Tightening torque for different threads

M10=50Nm

M12=90Nm

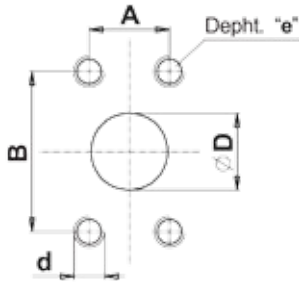

code S

Flanged ports
SAE J518
AMERICAN STANDARD
THREAD



TYPE	INLET				OUTLET			
	Ø D	B	A	d	Ø D	B	A	d
From 55 to 64	32 (1.26")	58.7 (2.31")	30.2 (1.26")	7/16-14 UNC	19 (0.75")	47.6 (1.87")	22.22 (0.87")	3/8-16 UNC
From 75 to 98	38 (1.50")	69.8 (2.75")	35.7 (1.41")		26 (1.02")	52.4 (2.06")	26.2 (1.03")	



BI-DIRECTIONAL PUMPS Special version available on request.

DRIVE SHAFTS

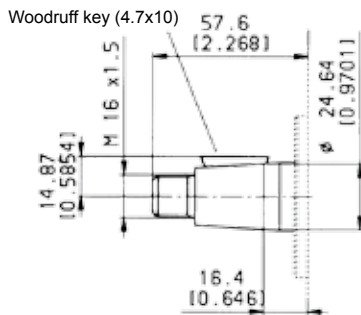

code 48 Max torque 420 Nm

Tapered 1:8

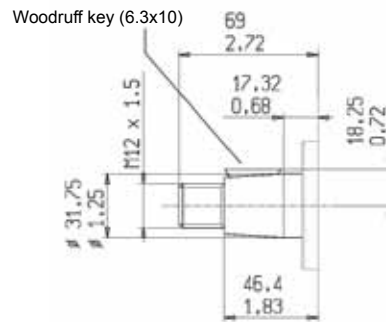

code 49 Max torque 460 Nm

Tapered 1:8 (only for P4)



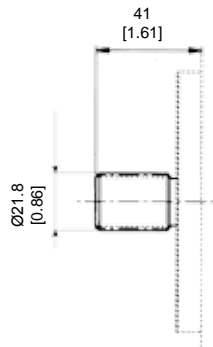

code 55 Max torque 300 Nm
SAE B Splined 13T-16/32DP
Ansi B92 1a 1976

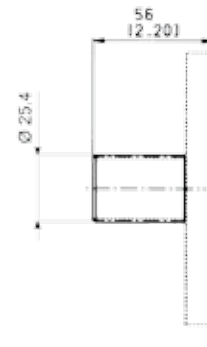

code 56 Max torque 460 Nm
SAE BB Splined 15T-16/32DP Ansi
B92 1a 1976

MOUNTING FLANGES

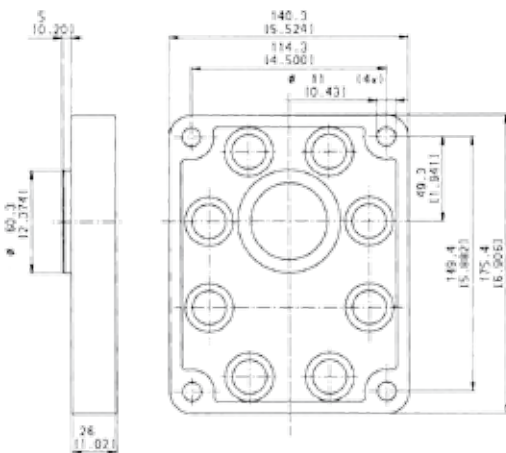

P3 European standard Ø60.3
With shaft code 48

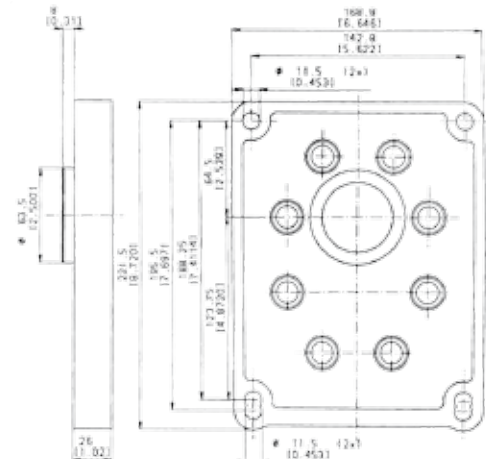

P4 European standard Ø63.5
With shaft code 49

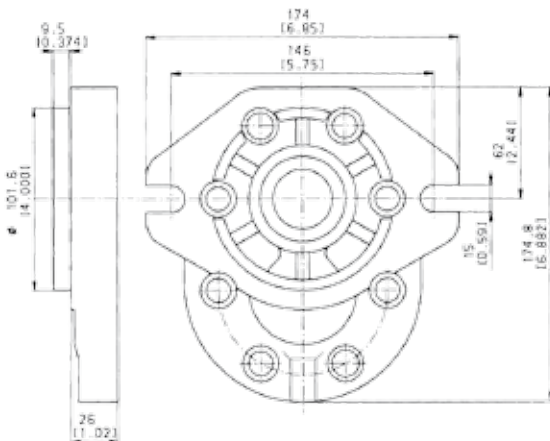

S3 SAE B 2 bolts
With shaft code 55-56

EO:114.0416.02.001M03



OUTRIGGER BEARING

Tightening torque 100 Nm

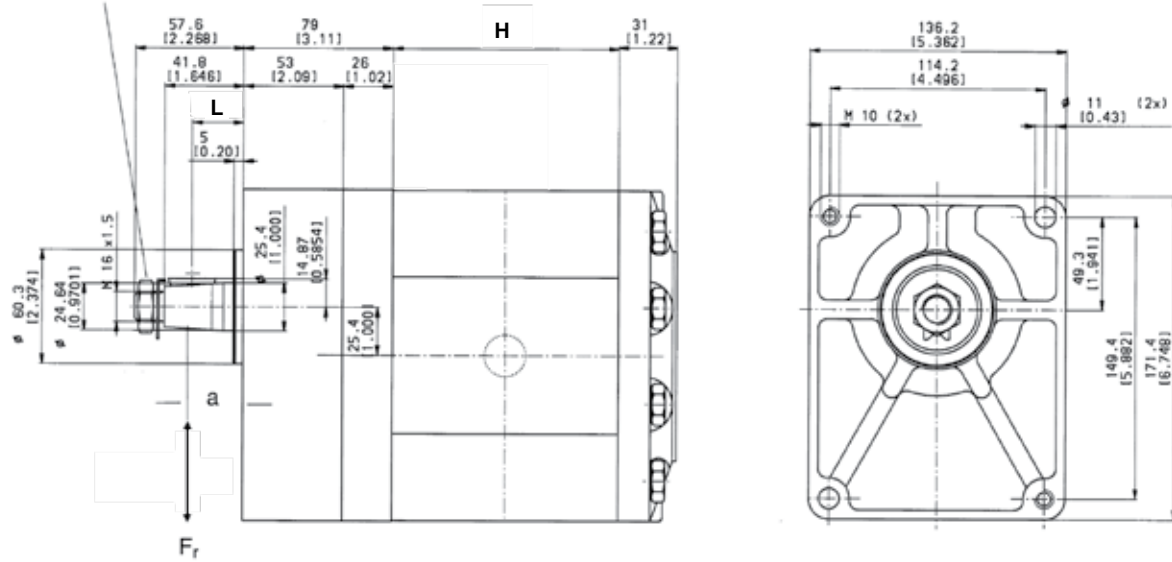

The following diagrams show radial load capability of the bearing.
Calculation according to ISO 281 at 10 cSt.

CP

European standard Ø60.3

With shaft code 48

TYPE	H
75	184 (7.24")
87	192 (7.55")
98	197 (7.75")

L=Distance between mounting flange and radial force point of application.

Example:
Fr = 5000 N
L = 25
Speed = 1500 rpm
→ Expected life: 700 hrs

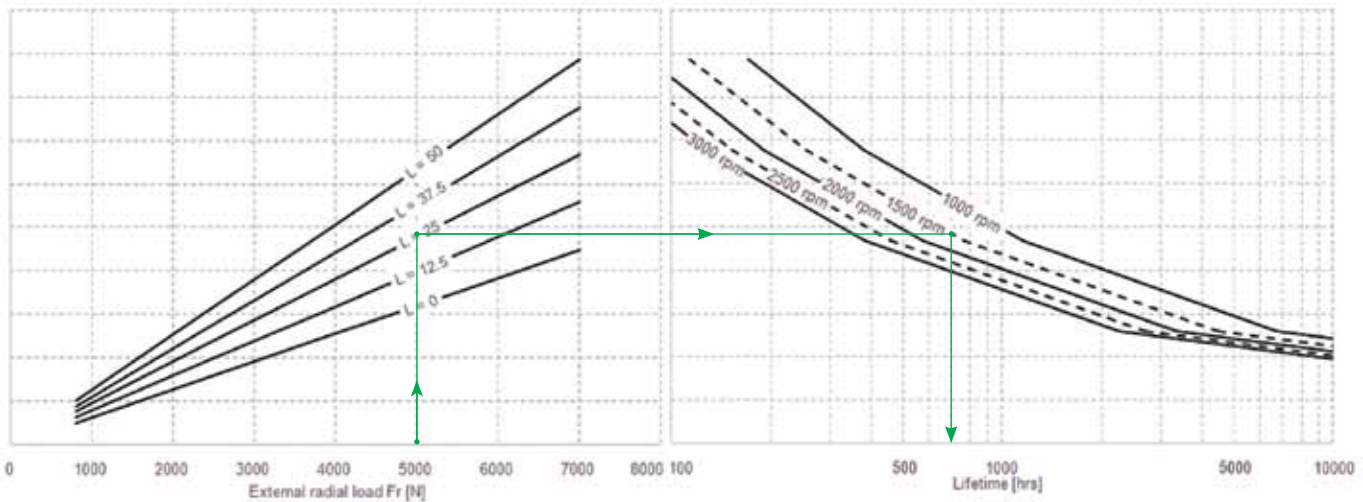

E0.114.0416.02.00IM03



**MULTIPLE GEAR PUMPS
ASSEMBLING DIMENSIONS**

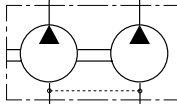

**MULTIPLE
GEAR PUMPS
with inlet port
on each body**

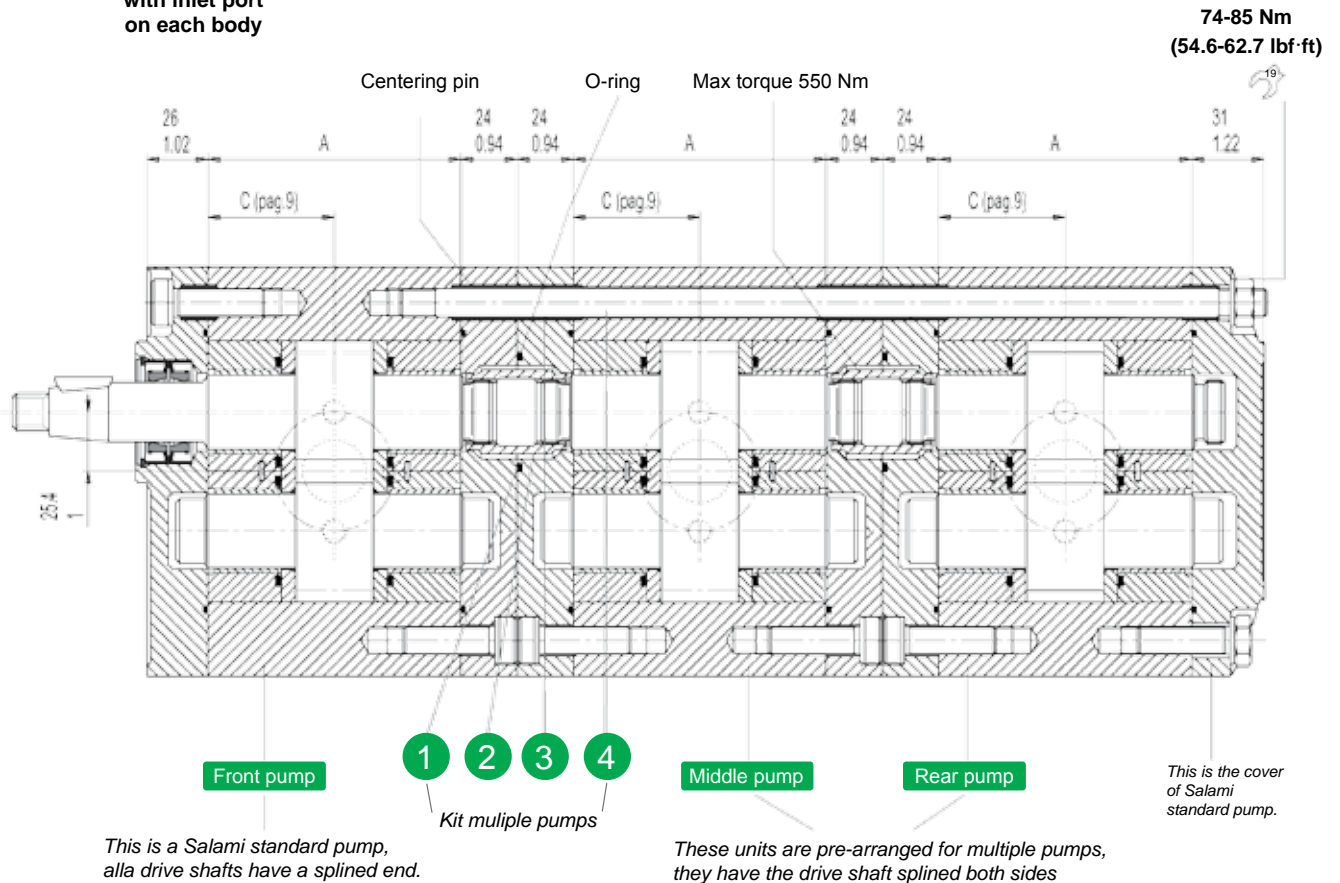

The 3.5PC pumps can be easily transformed into front pump in the multiple units. All drive shafts are pre-arranged and have a splined end according DIN 5482. The first unit must always be the same size or bigger than following units. The features and performances are the same of the corresponding single units: only in the case of simultaneous operating you have to verify that the inlet torque is lower than the max. transmissible by the drive shaft. In case of common inlet port, to avoid too high value of oil speed, 40l/min is the max. sucked flow for the downstream pump. Finally to assembly the multiple pump you need to order bolts of the right length.

*Commercial code UA.

Type		55	64	75	87	98
Dimension A	mm	108	120	127	135	140
	in	4.25	4.72	5.00	5.31	5.51
Dimension C	mm	80	86	89.5	93.5	96
	in	3.14	3.38	3.52	3.68	3.77

EO:114.0416:02.001M03



3.5PC COMBINATION WITH 3PE

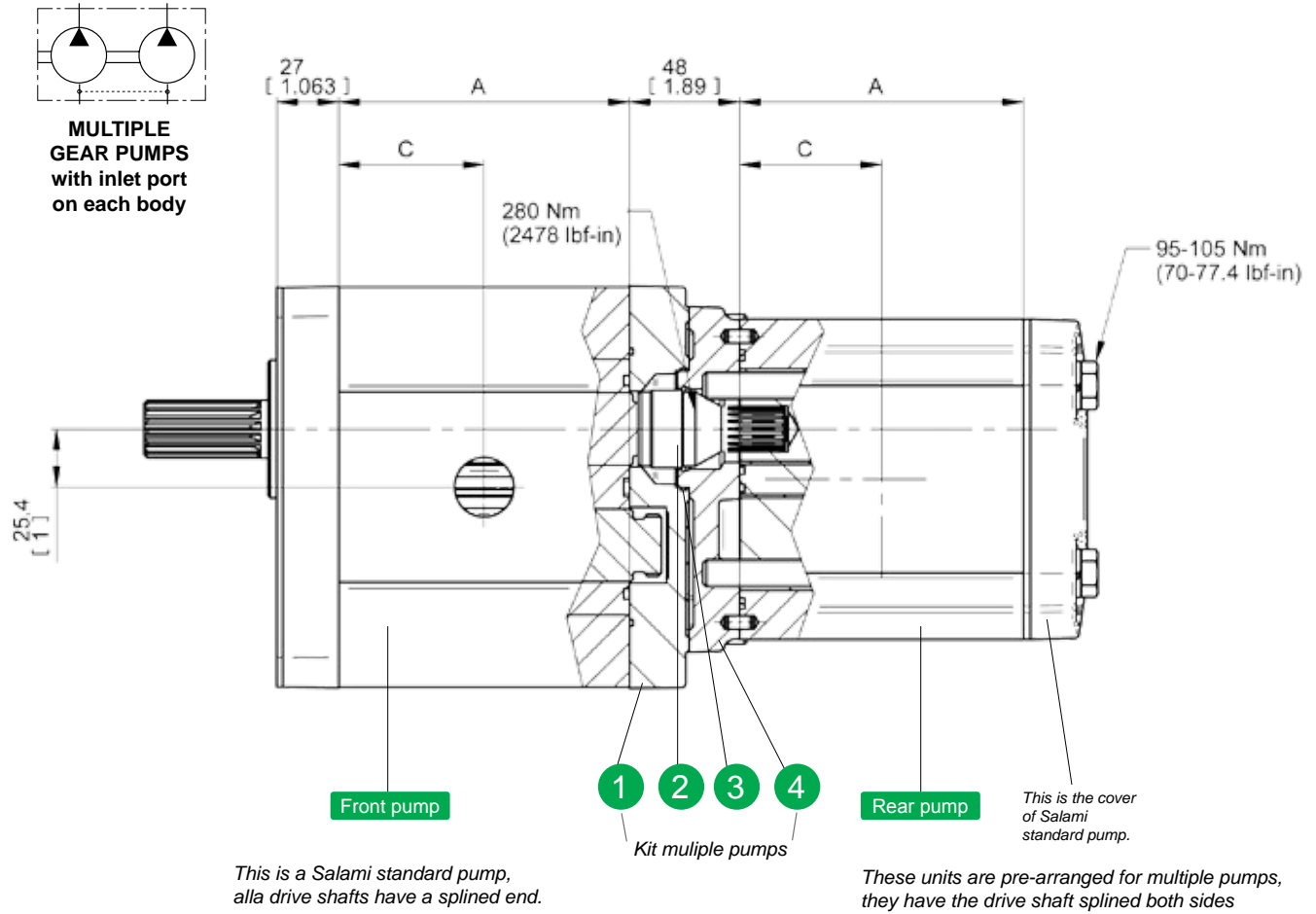

3.5PC dimensions A and C are available at the previous page.

3PE-Type		21*	27	33	38	46	55	65	75*
Dimension A	mm	74	79	84	88	104	110	117	124
	in	2.91	3.11	3.31	3.46	4.09	4.33	4.61	4.88
Dimension C	mm	37	39.5	42	44	52	55	58.5	62
	in	1.46	1.56	1.65	1.73	2.05	2.17	2.30	2.44

E0.114.0416.02.00IM03



3.5PC COMBINATION WITH 2PE

COMMUNICATING INLET PORT

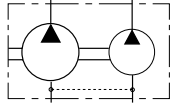

MULTIPLE GEAR PUMPS
with inlet port
on each body

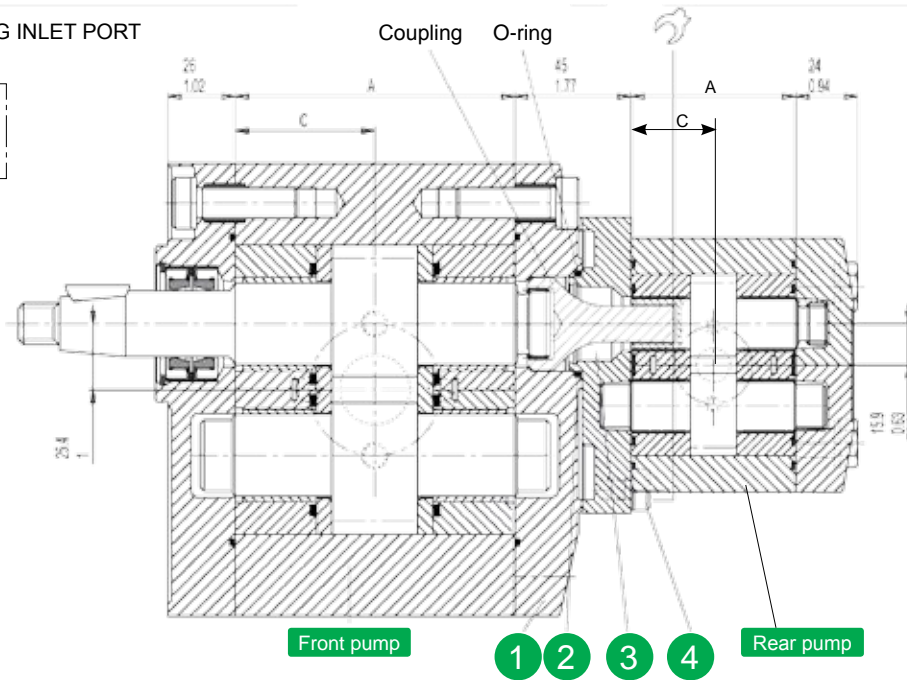

2PE-Type		3.2*	3.9*	4.5	6.5	8.3	10.5	11.3	12.5	13.8	16	19	22.5	26
Dimension A	mm in		47.1 1.83		49.95 1.97	52.8 2.07	56.3 2.22	59.7 2.35	63.5 2.5	67.5 2.65	75.6 2.97	81 3.19	86.8 3.42	
Dimension C	mm in		23.55 0.93		25 0.98	26.4 1.04	28.15 1.11	29.75 1.17	31.75 1.25	33.75 1.33	37.80 1.49	40.5 1.59	43.4 1.71	

*Available only as rear pump

SEPARATED STAGES

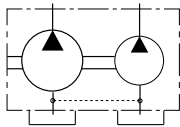

code AS

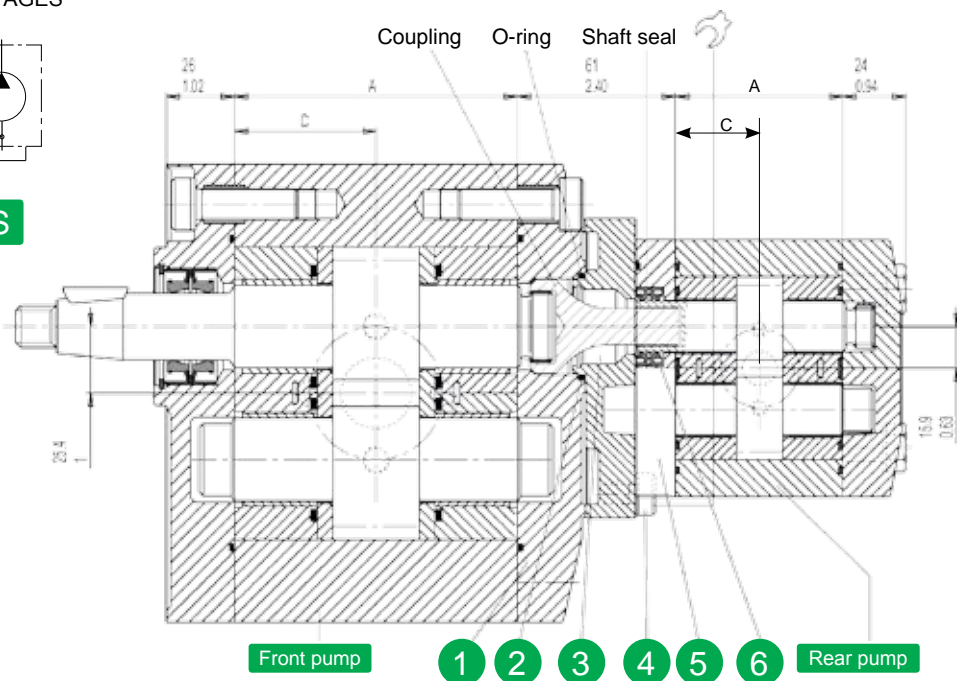

EO:114.0416.02.001M03



PERFORMANCE CURVES

Performance curves carried out with oil viscosity at 21 cSt and oil temperature at 50°C

Input power (kW)

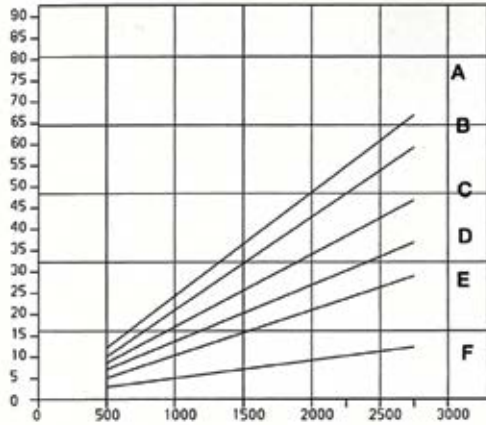

3.5PC - 55

- A=250bar - (3625 psi)
- A1=230bar - (3335 psi)
- B=220bar - (3190psi)
- C=175bar - (2538 psi)
- D=140bar - (2030 psi)
- E=105bar - (1522 psi)
- F=50bar - (725 psi)
- G=7bar - (101 psi)

Shaft speed r.p.m

Flow

U.S. g p m

l/min

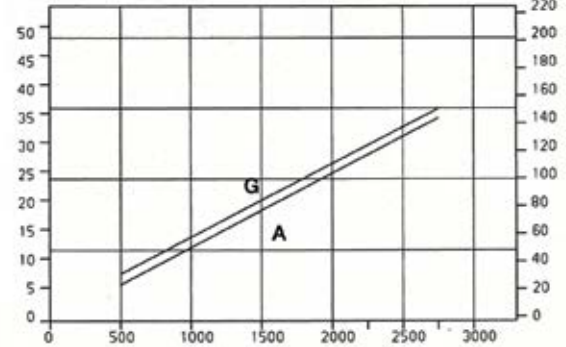

Input power (kW)

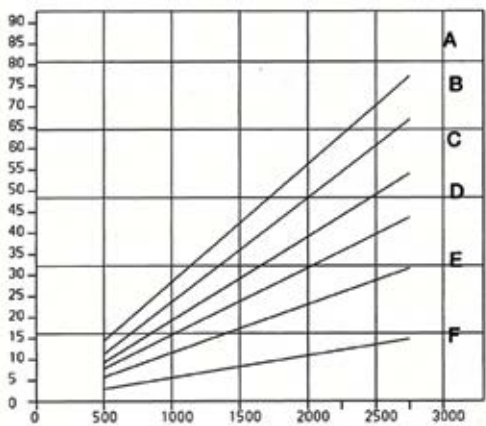

3.5PC - 64

Shaft speed r.p.m

Flow

U.S. g p m

l/min

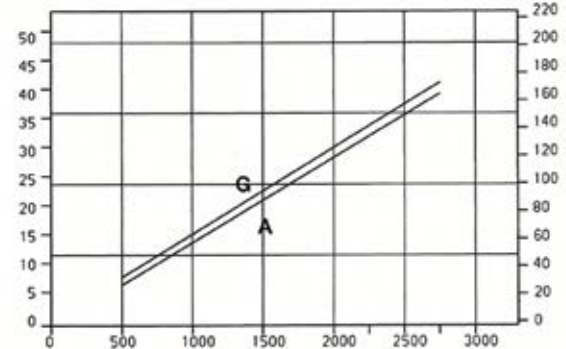

Input power (kW)

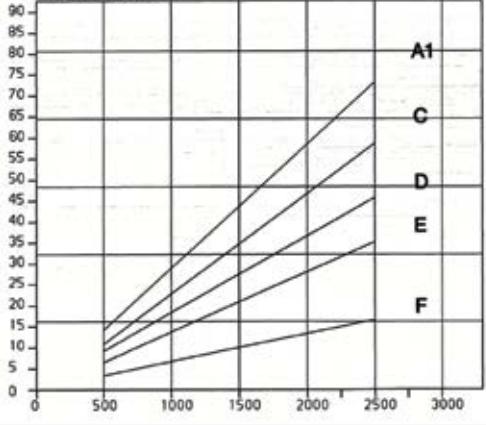

3.5PC - 75

Shaft speed r.p.m

Flow

U.S. g p m

l/min

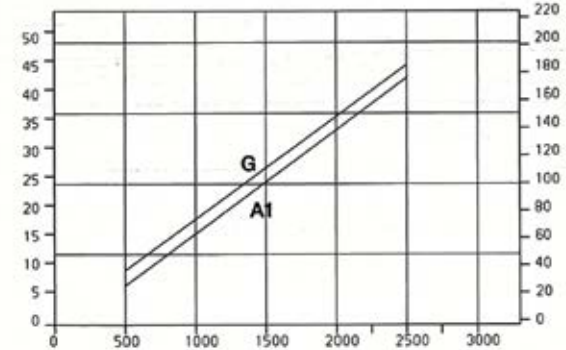

E0.114.0416.02.00IM03



Input power (kW)

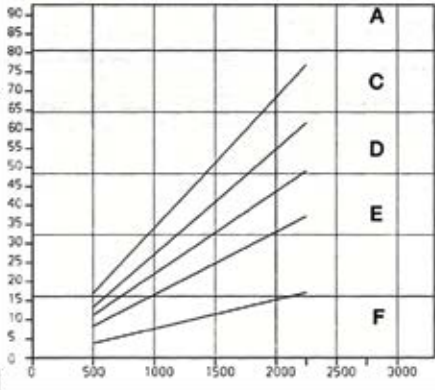

A=250bar - (3625 psi)
A1=230bar - (3335 psi)
B=220bar - (3190psi)
C=175bar - (2538 psi)
D=140bar - (2030 psi)
E=105bar - (1522 psi)
F=50bar - (725 psi)
G=7bar - (101 psi)

Shaft speed r.p.m

3.5PC - 87

Flow
U.S. g p m

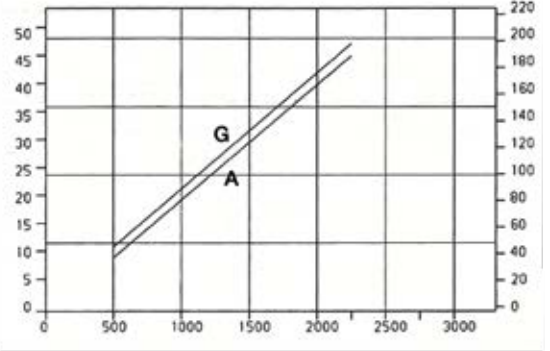

Flow
U.S. g p m

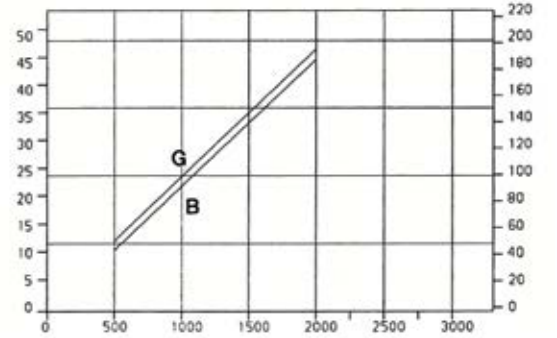

Shaft speed r.p.m

Input power (kW)

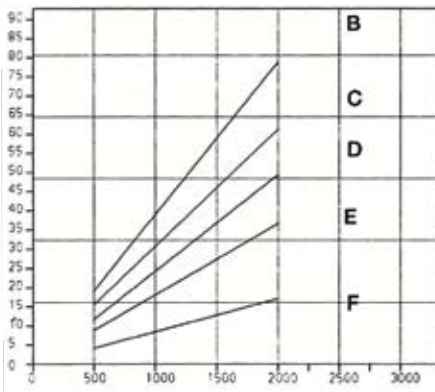

3.5PC - 98

EO:114.0416:02.001M03



SINGLE PUMPS

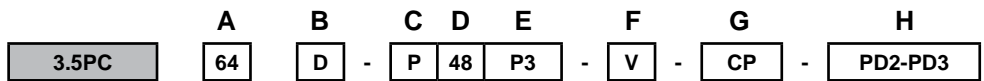

TYPE	A	DISPLACEMENTS	
55	54.8 cm ³ /rev.	3.34	cu.in/rev.
64	63.2 cm ³ /rev.	3.85	cu.in/rev.
75	74.7 cm ³ /rev.	4.55	cu.in/rev.
87	88 cm ³ /rev.	5.36	cu.in/rev.
98*	99 cm ³ /rev.	6.03	cu.in/rev.

ROTATION (page 4)	CODES	B
Clockwise	D	
Anti-clockwise	S	
Reversible	R	

PORTS (page 112)	CODES	C
Flanged ports european standard	P	
Flanged ports SAE (UNC)	S*	

DRIVE SHAFT (page 112)	CODES	D
Tapered 1:8 Ø24.64	48	
Tapered 1:8 Ø31.75	49	
SAE B splined 13T	55*	
SAE BB splined 15T	56*	

H	REAR COVER	CODES
	Pre-arranged for 3PE rear	PD3
	Pre-arranged for 2PE rear	PD2

GOUTRIGGER BEARING (page 114)	CODES
European standard	CP*

F	SEAL	CODE
	Buna standard	
	Viton	V

E	MOUNTING FLANGES (page 113)	CODES
	European standard Ø60.3	P3
	European standard interchangeable with 4PB Ø63.5	P4
	SAE B 2 bolts Ø101.6	S3*

*Available for quantity, please contact our sales department.

Order example 3.5PC 64D, ports european standard (P), drive shaft (48), mounting flange (P3)
3.5PC64D-P48P3

EO.114.0416.02.00IM03



MULTIPLE PUMPS

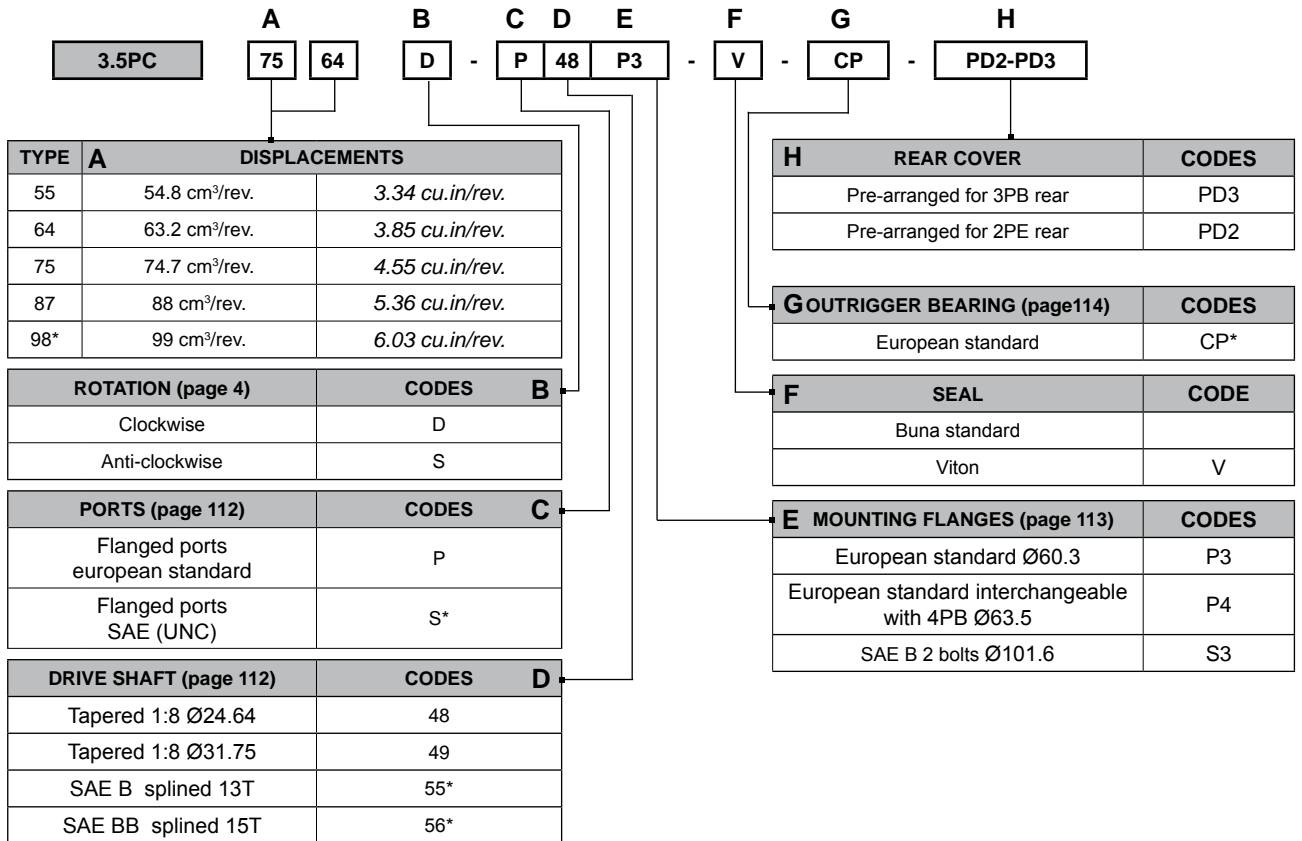

*Available for quantity, please contact our sales department.

EO:114.0416:02.00IM03

Order example 3.5PC 75/64D, ports SAE (S), drive shaft (56), mounting flange (S3):
3.5PC75/64D-S56S3

Order example 3.5PC 75, 3PB 38S ports european standard (P), drive shaft (48), mounting flange (P3):
3.5PC75/3PB38S-P48P3

Order example 3.5PC 64/2PE 16D, ports european standard (P), drive shaft (49), mounting flange (P4) - separated stages (AS):
3.5PC64/2PE16D-P49P4-AS



You can find our most up to date “STANDARD SALES CONDITIONS” on our website.

Potete trovare le nostre più aggiornate “CONDIZIONI DI VENDITA STANDARD” sul nostro sito.

www.salami.it

T. +39 059 387 411

sales@salami.it

Watch our tutorials on youtube channel



Salami Fluid Power
Salami Fluid Power World
Salami Fluid Power France
Salami Fluid Power España
Salami Fluid Power Deutsch

SALAMI S.P.A.

Via Emilia Ovest 1006
41121 Modena (Italy)
T. +39 059 387 411
F. +39 059 387 639
sales@salami.it

SALAMI ESPAÑA

Poligono Industrial Armenteres
C/Primer de Maig, 18, Nave 4
08980 San Feliu de Llobregat
Barcelona
T. +34-93-6327288
F. +34-93-6667826
info@salamispain.com

SALAMI FRANCE

22, rue Louis Saillant
69120 Valux en Velin
Lyon
T. +33-04-78809941
F. +33-04-78804264
e.pasian@salami.fr

SALAMI HYDRAULICS N.A INC

Loop Road
Baldwinsville
NY 13027 - USA
T. +1-315-295-2363
F. +1-315-295-2364
info@salamihydraulics.com