

---

# 3PE

---

## Aluminium gear pumps

---

### Technical Catalogue

E0.130.0416.02.00IM02



**GEAR PUMPS**

SALAMI gear pumps are available with displacements from 1.4 cm<sup>3</sup>/rev to 99 cm<sup>3</sup>/rev (from 0.09 cu.in/rev to 6.03 cu.in/rev).

Multiple pumps can always be realized combining stages taken from different or same series.

Several options of shafts, flanges and ports as for European, German and American standards are available for all the pumps.

SALAMI gear pumps offer:

- High volumetric efficiency thanks to an innovative design and an accurate control of machining tolerances.
- Axial compensation achieved by the use of floating bushes that allow high volumetric efficiency throughout the working pressure range.
- DU bearings to ensure high pressure capability.
- 12 teeth integral gear and shaft.
- Aluminium body.
- Cast iron flange and cover.
- Double shaft seals.
- Nitrile seals as standard and Viton seals in high temperature applications.
- All pumps are hydraulically tested after assembly to ensure the highest standard performance.
- Gear pumps are ideal for mobile equipment including: snow plows, light duty equipment, farm vehicles, town trucks, cherry pickers, lift gates, utility vehicles, aerial devices, hoists, spreaders, fan drive.
- Also available Bidirectional rotation.

**TECHNICAL DATA**

- Pump inlet pressure (absolute pressure)	0.8 to 1.5 bar (11.6 to 21.7 psi)
- Minimum operating fluid viscosity	12 mm <sup>2</sup> / sec
- Max starting viscosity	800 mm <sup>2</sup> / sec
- Suggested fluid viscosity range	17 - 65 mm <sup>2</sup> / sec
- Fluid operating temperature range	-20 to 80 °C
- Fluid operating temperature range with FPM seals (Viton)	-15 to 110°C
- Fluid operating temperature range with HNBR seals*	-30 to 110°C
- Hydraulic fluid	mineral oil

\*Available on request.

**Important:**

in case of assembling of pumps without shaft seals (eg. B4 - B5....), you have to keep the value of min. suction pressure ( 0.8 bar (abs)) in the vane between pump and coupling too.  
Lower pressure can lead to suction of oil through the front flange (seat of the shaft without seal); this can damage seriously the pump.

**DEFINITION OF PRESSURES**

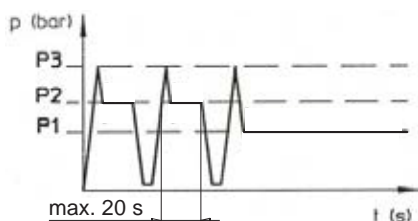

- P3 = Peak pressure
- P2 = Intermittent operating pressure (1/3 of working time)
- P1 = Continuous operating pressure

EO.100.0416.02.001M00



### DRIVE SHAFTS

Radial and axial loads on the shafts must be avoided since they reduce the life of the unit. In order to avoid misalignment during the assembly with the primary engine, a connection with “Oldham” coupling (or coupling having convex toothed hub) is recommended.

### ROTATION

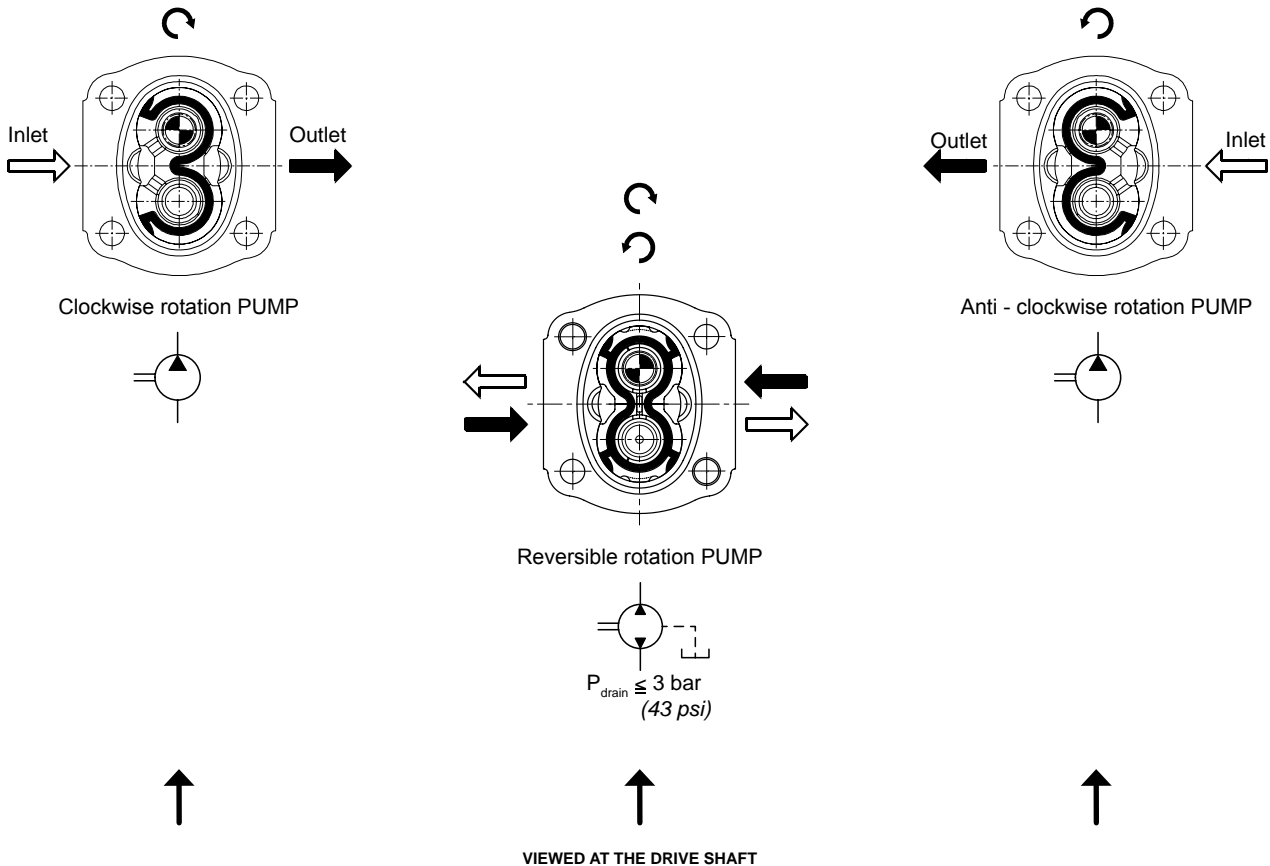

### HYDRAULIC PIPE LINE

To ensure favorable suction conditions it is important to keep pressure drop in suction pipe line to a minimum value (see TECHNICAL DATA). To calculate hydraulic pipe line size, the designer can use; as an approximate guide, the following fluid speed figures:

From 1 to 2 m/sec on suction pipe line  
From 6 to 10 m/sec on pressure pipe line

From 3.28 to 6.36 ft/sec on suction pipe line  
From 19.7 to 32.8 ft/sec on pressure pipe line

The lowest fluid speed values in pipe lines is recommended when the operating temperature range is high and/or for continuous duty.

The highest value is recommended when the temperature difference is low and/or for intermittent duty.

When tandem pumps are supplied by 2 different reservoirs with 2 different fluids it is necessary to specify “AS” version.



**FILTRATION INDEX RECOMMENDED**

Working pressure	>200 bar/2900 psi	<200 bar/2900 psi
Contamination class NAS 1638	9	10
Contamination class ISO 4406	19/18/15	20/19/16
Achieved with filter $\beta_x=75$	15 $\mu\text{m}$	25 $\mu\text{m}$

**FIRE RESISTENT FLUID**

Type	Description	Max pressure	Max speed (rpm)	Temperature
HFB	Oil emulsion with 40% water	130 bar/1880 psi	2500	3°C+65°C
HFC	Water glycol	180 bar/2600 psi	1500	-20°C+65°C
HFD	Phosphate esters		1750	-10°C+80°C

**COMMON FORMULAS FOR PUMPS**

$$C = \text{Input torque} = \frac{q \cdot \Delta p}{62.8 \cdot \eta_m} \text{ (Nm)}$$

$$P = \text{Input power} = \frac{q \cdot n \cdot \Delta p \cdot 10^{-3}}{600 \eta_m} \text{ (kW)}$$

$$Q = \text{Outlet flow} = \frac{q \cdot n \cdot \eta_v}{1000} \text{ (l/min)}$$

LEGENDA

$\Delta p$  = Working pressure (bar)

$q$  = Displacement ( $\text{cm}^3/\text{rev}$ )

$n$  = Speed ( $\text{min}^{-1}$ )

$\eta_m$  = Mechanical eff. (0.92)

$\eta_v$  = Volumetric eff. (0.95)

**IDENTIFICATION LABEL**

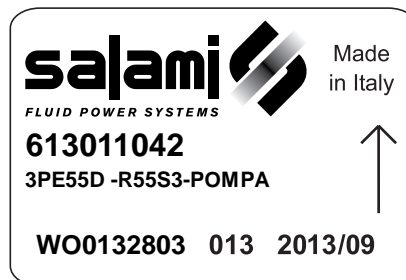

Salami part number  
Product short description

Rotation sense

Product code (for Salami management)

Month and year of made  
Number of assembling

EO.100.0416.02.001M00



### WORKING CONDITIONS

	Displacement		Working pressure P <sup>1**</sup>		Intermittent pressure P <sup>2</sup>		Peak pressure P <sup>3</sup>		Max. speed	Min. speed
	cm <sup>3</sup> /rev	cu.in/rev	bar	psi	bar	psi	bar	psi		
<b>GROUP 1.5 - E SERIES</b>									min <sup>-1</sup>	
1.5PE - 1.4	1.4	0.09	250	3625	270	3915	290	4205	5000	700
1.5PE - 2.1	2.1	0.13	250	3625	270	3915	290	4205	5000	700
1.5PE - 2.8	2.8	0.17	250	3625	270	3915	290	4205	4500	700
1.5PE - 3.5	3.5	0.21	250	3625	270	3915	290	4205	4500	700
1.5PE - 4.1	4.1	0.25	250	3625	270	3915	290	4205	4000	700
1.5PE - 5.2	5.2	0.32	230	3335	250	3625	270	3915	4000	700
1.5PE - 6.2	6.2	0.38	230	3335	250	3625	270	3915	3600	600
1.5PE - 7.6	7.6	0.46	200	2900	220	3190	250	3625	3300	600
1.5PE - 9.3	9.3	0.57	180	2610	200	2900	240	3480	3000	600
1.5PE - 11	11	0.67	170	2465	190	2755	220	3190	3000	600

	Displacement		Working pressure P <sup>1**</sup>		Intermittent pressure P <sup>2</sup>		Peak pressure P <sup>3</sup>		Max. speed	Min. speed
	cm <sup>3</sup> /rev	cu.in/rev	bar	psi	bar	psi	bar	psi		
<b>GROUP 2 - E SERIES</b>									min <sup>-1</sup>	
2PE - 3.2*	3.2	0.19	250	3625	280	4060	300	4350	4000	600
2PE - 3.9*	3.9	0.24	250	3625	280	4060	300	4350	4000	600
2PE - 4.5	4.6	0.27	250	3625	280	4060	300	4350	4000	600
2PE - 6.5	6.5	0.4	250	3625	280	4060	300	4350	4000	600
2PE - 8.3	8.2	0.5	250	3625	280	4060	300	4350	3500	500
2PE - 10.5	10.6	0.65	250	3625	280	4060	300	4350	3500	500
2PE - 11.3	11.5	0.68	250	3625	280	4060	300	4350	3500	500
2PE - 12.5	12.7	0.77	250	3625	280	4060	300	4350	3500	500
2PE - 13.8	13.8	0.84	250	3625	280	4060	300	4350	3500	500
2PE - 16	16.6	1.01	250	3625	280	4060	300	4350	3000	400
2PE - 19	19.4	1.15	220	3140	240	3480	260	3750	3000	400
2PE - 22.5	22.9	1.37	200	2900	220	3140	240	3480	2750	400
2PE - 26	25.8	1.58	180	2610	200	2900	220	3190	2500	400

\*Available only as rear pump

	Displacement		Working pressure P <sup>1**</sup>		Intermittent pressure P <sup>2</sup>		Peak pressure P <sup>3</sup>		Max. speed	Min. speed
	cm <sup>3</sup> /rev	cu.in/rev	bar	psi	bar	psi	bar	psi		
<b>GROUP 2.5 - B SERIES</b>									min <sup>-1</sup>	
2.5PB - 5.5*	5.97	0.36	250	3625	280	4060	300	4350	3000	600
2.5PB - 8.3*	8.29	0.50	250	3625	280	4060	300	4350	3000	600
2.5PB - 11.5*	11.76	0.72	250	3625	280	4060	300	4350	3000	600
2.5PB - 13.8*	14.07	0.86	250	3625	280	4060	300	4350	3000	600
2.5PB - 16	16	0.97	250	3625	280	4060	300	4350	3000	600
2.5PB - 19	19.3	1.17	250	3625	280	4060	300	4350	3000	600
2.5PB - 22	22.2	1.35	250	3625	280	4060	300	4350	3000	500
2.5PB - 25	25.2	1.53	250	3625	280	4060	300	4350	3000	500
2.5PB - 28	27.6	1.68	250	3625	280	4060	300	4350	3000	500
2.5PB - 32	32.4	1.97	230	3330	250	3625	260	3750	3000	500
2.5PB - 38	38.1	2.32	200	2900	220	3140	240	3480	2750	400
2.5PB - 44	44.2	2.69	170	2465	190	2755	210	3040	2500	400

\*Available only as rear pump. Displacements 11.5-13.8 are available as single pump only with drive shaft “55”.



	Displacement		Working pressure P <sup>1**</sup>		Intermittent pressure P <sup>2</sup>		Peak pressure P <sup>3</sup>		Max. speed	Min. speed
	cm <sup>3</sup> /rev	cu.in/rev	bar	psi	bar	psi	bar	psi		
<b>GROUP 3 - E SERIES</b>									min <sup>-1</sup>	
3PE - 21*	20.6	1.26	250	3625	280	4060	300	4350	3000	600
3PE - 27	27	1.65	250	3625	280	4060	300	4350	3000	600
3PE - 33	33.5	2.04	250	3625	280	4060	300	4350	3000	600
3PE - 38	38.7	2.36	250	3625	280	4060	300	4350	2750	500
3PE - 46	46.9	2.86	250	3625	270	3915	280	4060	2750	500
3PE - 55	54.1	3.3	220	3140	240	3480	250	3625	2500	400
3PE - 65	63.1	3.85	200	2900	220	3140	240	3480	2500	400
3PE - 75*	73.4	4.48	180	2610	200	2900	220	3140	2500	400

\*Displacements 21 and 75 are special release, please contact sales department.

	Displacement		Working pressure P <sup>1**</sup>		Intermittent pressure P <sup>2</sup>		Peak pressure P <sup>3</sup>		Max. speed	Min. speed
	cm <sup>3</sup> /rev	cu.in/rev	bar	psi	bar	psi	bar	psi		
<b>GROUP 3.5 - C SERIES</b>									min <sup>-1</sup>	
3.5PC - 55	54.8	3.34	250	3625	280	4060	300	4350	2750	400
3.5PC - 64	63.2	3.85	250	3625	280	4060	300	4350	2750	350
3.5PC - 75	74.7	4.55	230	3330	250	3625	280	4060	2500	300
3.5PC - 87	88	5.36	210	3040	230	3330	260	3750	2250	300
3.5PC - 98*	99	6.03	200	2900	220	3140	250	3625	2000	300

\*Displacement 98 are special release, please contact sales department.

\*\*For working conditions, using exclusively pressure P<sup>1</sup>, the value of max. speed must be reduced of 10%.

For bidirectional pump the max pressure has to be reduced of 10%.

The max pressure is referred to pumps with flanged ports, using the threaded ports the pump life could be reduced.



### ROTATION CHANGING INSTRUCTIONS FOR UNITS

Before starting, be sure that the pump is cleaned externally as well as the working area to avoid that particles dangerous for pump working can find their way into the pump. Pump represented is a clockwise rotation pump.

To obtain an anti\_clockwise rotation read carefully the following instructions.

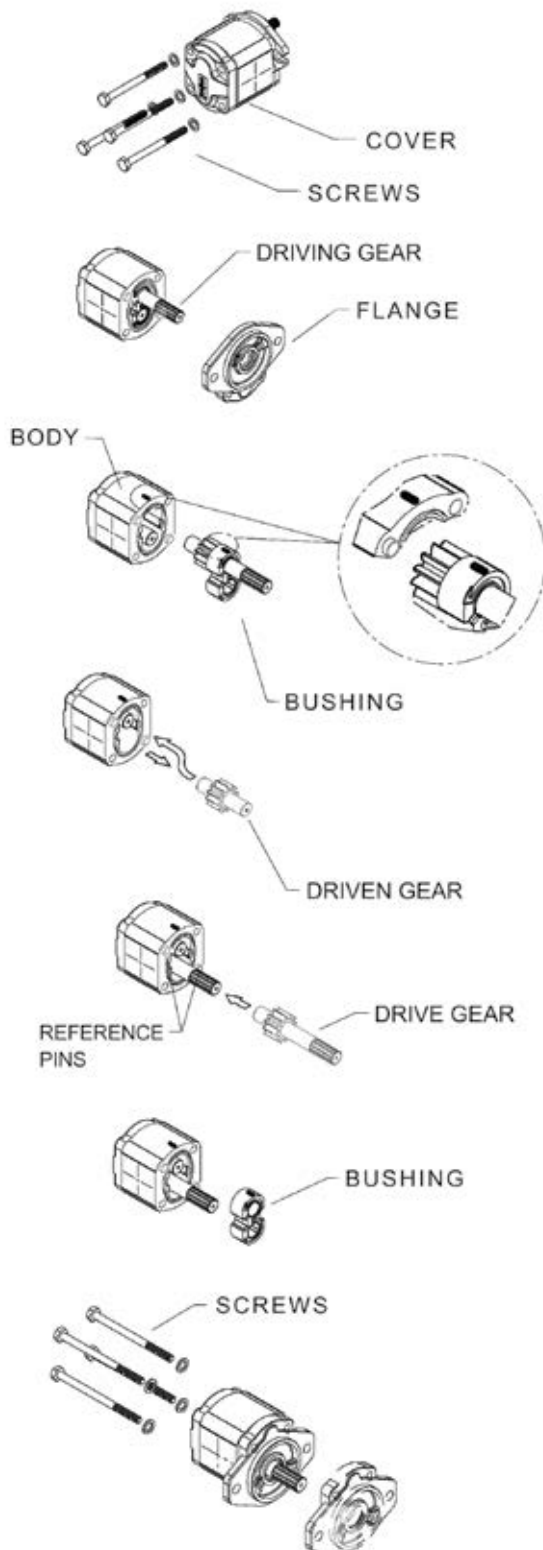

- 1 - Loosen and fully unscrew the screws.
- 2 - Lay the pump on the working area in order to have the mounting flange turned upside.
- 3 - Coat the shaft extension with grease to avoid damaging the shaft seal.
- 4 - Remove the flange and lay it on the working area; verify that the seal is correctly located in the body seat.

- 1 - Mark the position of the bushing and eventually the thrust plate, relative to the body.
- 2 - Remove the bushing, thrust plate and the driving gear taking care to avoid driven gear axial shifts.

- 1 - Draw out the driven gear from its housing, taking care to avoid rear cover axial shifts.
- 2 - Re-locate the driven gear in the position previously occupied by the driving gear.

- 1 - Re-locate the driving gear in the position previously occupied by the driven gear.

- 1 - Replace the bushing and thrust plate taking care that:
  - marks are located as on the picture
  - surface containing the seal is visible
  - seal and its protection are correctly located

- 1 - Clean body and mounting flange refaced surfaces.
- 2 - Verify that the two plugs are located in the body.
- 3 - Refit the mounting flange, turned 180° from its original position.
- 4 - Replace the clamp bolts and tighten crosswise evenly to a torque you will find at page 8.
- Check that the shaft rotates freely.
- 6 - Mark on the flange the new direction of rotation.

---

**INDEX**

---

Shafts And Flanges Combination .....	85
Assembling Dimensions .....	86
Flanged And Threaded Ports.....	88
Drive Shafts .....	90
Mounting Flanges .....	91
Outrigger Bearing .....	92
Mounting Flanges With Outrigger Bearing Support.....	93
Rear Cover .....	94
Priority Valves.....	95
Multiple Gear Pumps Assembling Dimensions.....	97
3PE Combination With Pump 2PE .....	98
3PE Combination With Pump 1.5PE .....	98
Performance Curves.....	99
How To Order Single Pump .....	103
How To Order Multiple Pumps.....	104

**Final revised edition-April 2016**

The data in this catalogue refers to the standard product.

The policy of Salami S.p.A. consists of a continuous improvement of its products. It reserves the right to change the specifications of the different products whenever necessary and without giving prior information.







***If any doubts, please get in touch with our sales department.***



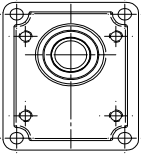
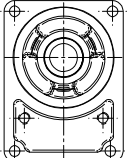
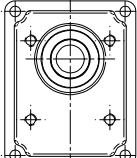
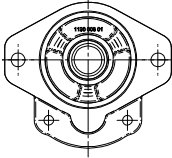

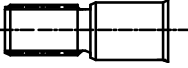

**SHAFTS AND FLANGES COMBINATION**

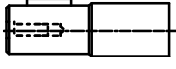
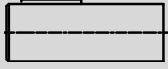
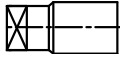
<p><b>3PE</b></p>	 <p>CODE <b>P2</b> - European stand.</p>	 <p>CODE <b>B6</b> - German stand.</p>	 <p>CODE <b>P3</b> - European stand. for 3,5PC</p>	 <p>CODE <b>S3</b> - SAE B</p>
 <p>CODE <b>35</b> - Tapered 1:5</p>		<p>35B6</p>		
 <p>CODE <b>38</b> - Tapered 1:8</p>	<p>38P2</p>			
 <p>CODE <b>48</b> - Tapered 1:8 for 3,5PC</p>			<p>48P3</p>	
 <p>CODE <b>55</b> - SAE B 13T</p>				<p>55S3</p>
 <p>CODE <b>56</b> - SAE BB 15T</p>				<p>56S3</p>
 <p>CODE <b>87</b> - SAE B parallel</p>				<p>87S3</p>
 <p>CODE <b>88</b> - SAE BB parallel</p>				<p>88S3</p>
 <p>CODE <b>05</b> - Tang drive for electric motors</p>		<p>05B6</p>		

EO.130.0416.02.001M02



Displacements up to 4.48 cu.in./rev  
Pressure up to 4350 psi



GEAR PUMPS

Displacements up to 73.4 cm<sup>3</sup>/rev  
Pressure up to 300 bar

### ASSEMBLING DIMENSIONS

Type		21*	27	33	38	46	55	65	75*
Displacement	cm <sup>3</sup> /rev	20.6	27	33.5	38.7	46.9	54.1	63.1	73.4
	cu.in./rev	1.26	1.65	2.04	2.36	2.86	3.3	3.85	4.48
Dimension A	mm	74	79	84	88	104	110	117	124
	in	2.91	3.11	3.31	3.46	4.09	4.33	4.61	4.88
Dimension C	mm	37	39.5	42	44	52	55	58.5	62
	in	1.46	1.56	1.65	1.73	2.05	2.17	2.30	2.44
Weight	kg	8.6	8.9	9.1	9.4	10.1	10.5	10.8	11.2
	lbs	19	19.6	20.1	20.6	22.3	23	23.8	24.6

\*Displacements 21 and 75 are special release, please contact sales department.

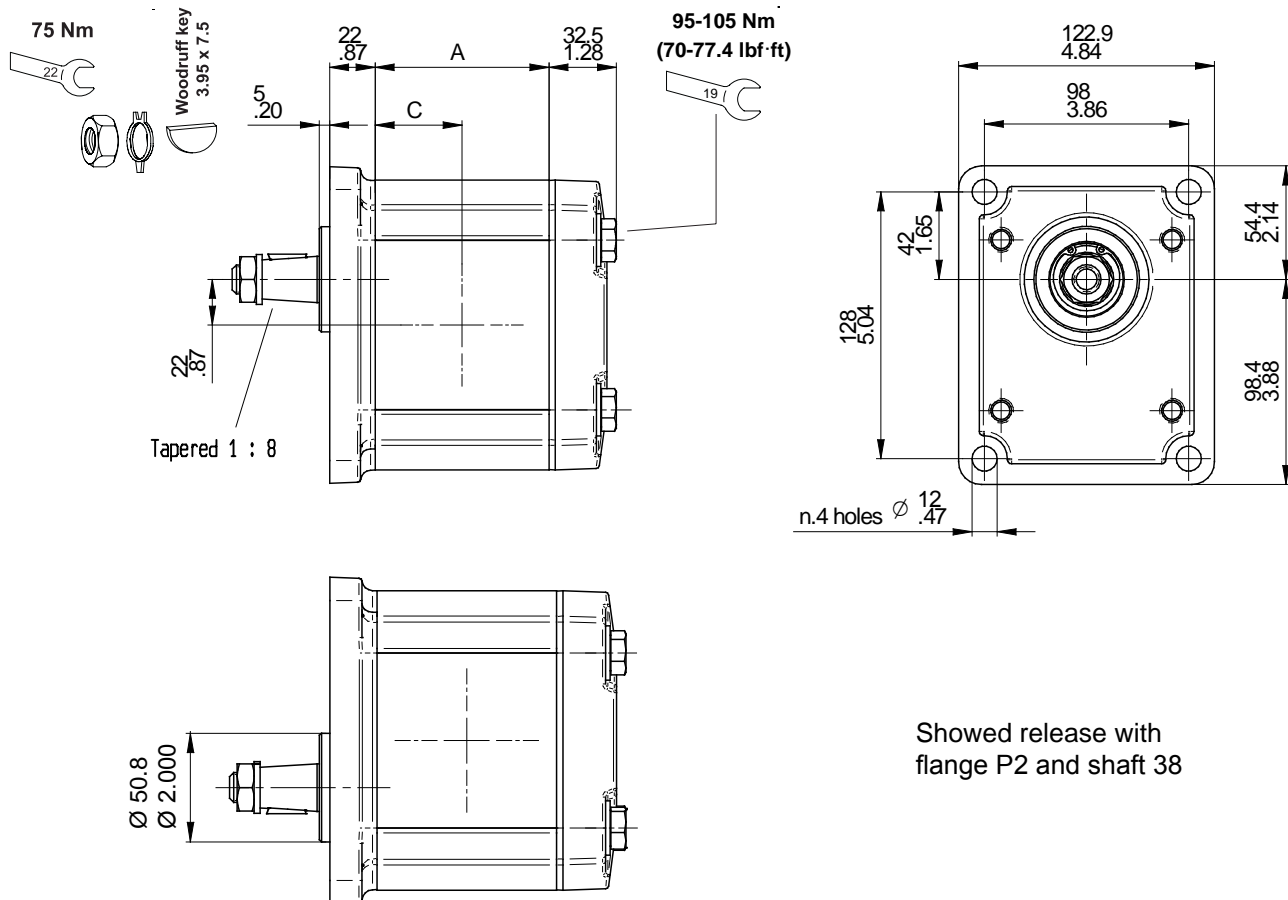

E0.130.0416.02.00IM02



Displacements up to 4.48 cu.in./rev  
Pressure up to 4350 psi



**GEAR PUMPS**

Displacements up to 73.4 cm<sup>3</sup>/rev  
Pressure up to 300 bar

**ASSEMBLING DIMENSIONS**

Type		46	55	65	75*
Displacement	cm <sup>3</sup> /rev	46.9	54.1	63.1	73.4
	cu.in./rev	2.86	3.3	3.85	4.48
Dimension A	mm	104	110	117	124
	in	4.09	4.33	4.61	4.88
Dimension C	mm	52	55	58.5	62
	in	2.05	2.17	2.30	2.44
Weight	kg	10.1	10.5	10.8	11.2
	lbs	22.3	23	23.8	24.6

\*Displacements 75 are special release, please contact sales department.

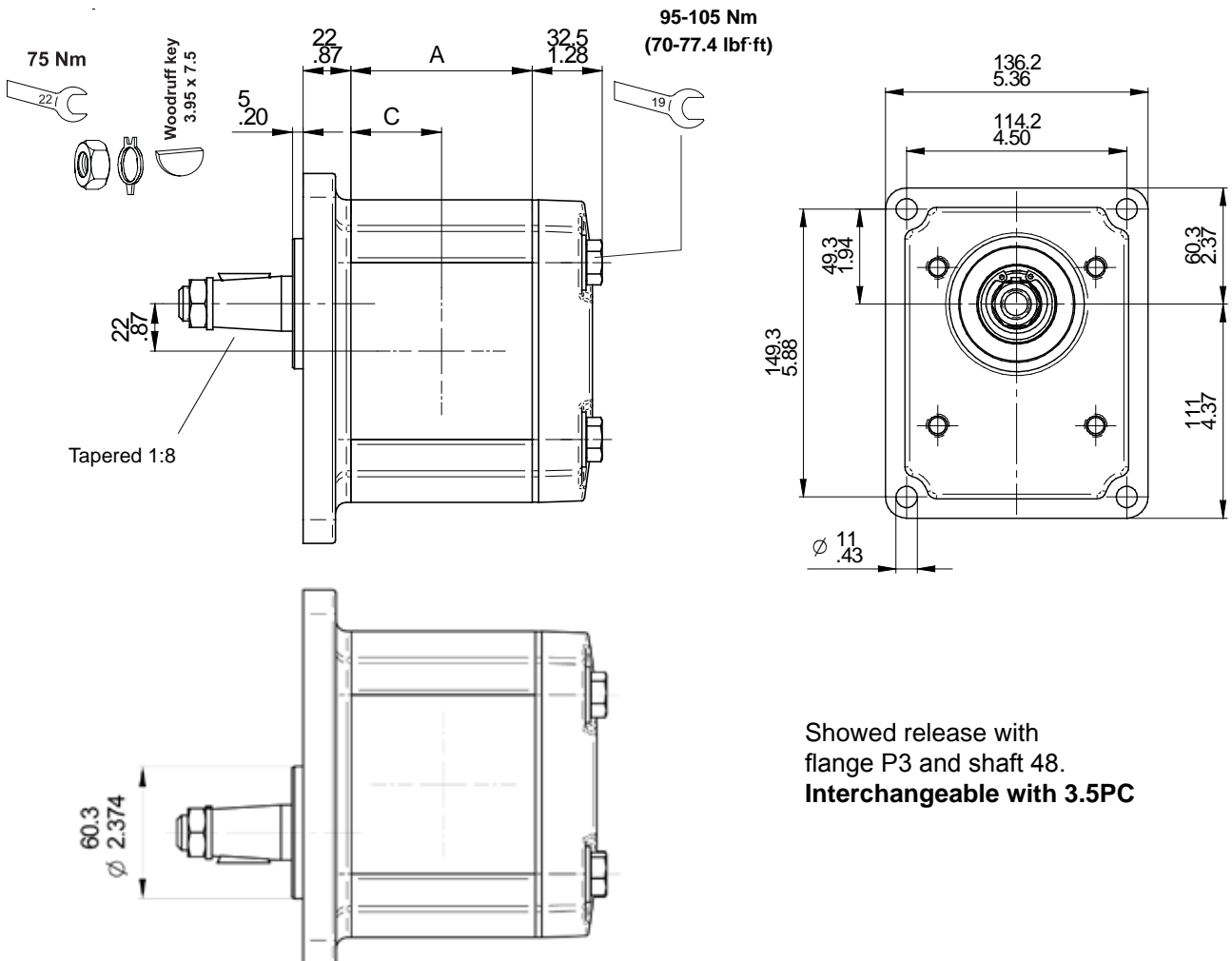

EO.130.0416.02.001M02



FLANGED AND THREADED PORTS

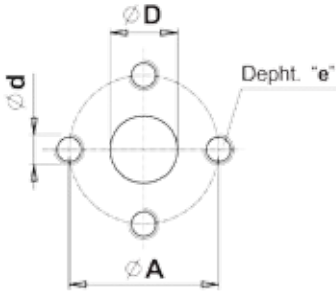

code P

Flanged ports  
european standard

UNI-DIRECTIONAL PUMPS	TYPE	INLET				OUTLET			
		Ø D	Ø A	d	e	Ø D	Ø A	d	e
	From 21 to 55	27 (1.06")	51 (2.01")	M10	16 (0.63")	16 (0.63")	40 (1.57")	M8	16 (0.63")
	From 65 to 75	33 (1.3")	62 (2.44")	M12		21 (0.83")	51 (2.01")	M10	



BI-DIRECTIONAL PUMPS Special version available on request.

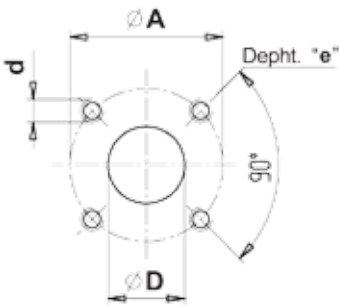

code B

Flanged ports  
german standard

UNI-DIRECTIONAL PUMPS	TYPE	INLET				OUTLET			
		Ø D	Ø A	d	e	Ø D	Ø A	d	e
	21	22 (0.86")	55 (2.17")	M8	13 (0.51")	19 (0.75")	55 (2.17")	M8	13 (0.51")
	From 27 to 75	27 (1.06")				19 (0.75")	55 (2.17")	M8	13 (0.51")



BI-DIRECTIONAL PUMPS Special version available on request.

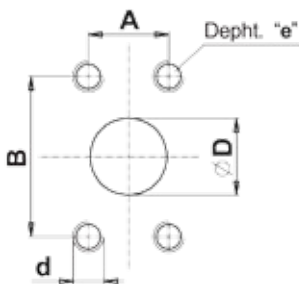

code W

Flanged ports  
SAE J518  
METRIC THREAD

UNI-DIRECTIONAL PUMPS	TYPE	INLET					OUTLET				
		ØD	B	A	d	e	ØD	B	A	d	e
	From 21 to 38	26 (1.02")	52.4 (2.06")	26.2 (1.03")	M10	18 (0.71")	19 (0.75")	47.6 (1.87")	22.2 (0.87")	M10	18 (0.71")
	From 46 to 75	32 (1.26")	58.7 (2.31")	30.2 (1.19")			26 (1.02")	52.4 (2.06")	26.2 (1.03")		



BI-DIRECTIONAL PUMPS Special version available on request.

E0.130.0416.02.00IM02



# GEAR PUMPS "E" SERIES

Aluminium Body

3PE

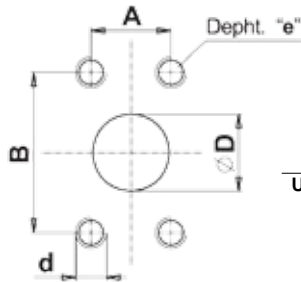

**code S**

Flanged ports  
SAE J518  
AMERICAN STANDARD  
THREAD

UNI-DIRECTIONAL PUMPS	TYPE	INLET					OUTLET				
		ØD	B	A	d	e	ØD	B	A	d	e
	From 21 to 38	26 (1.02")	52.4 (2.06")	26.2 (1.03")	3/8 16 UNC	18 (0.71")	19 (0.75")	47.6 (1.87")	22.2 (0.87")	3/8 16 UNC	18 (0.71")
	From 46 to 75	32 (1.26")	58.7 (2.31")	30.2 (1.19")	7/16 14 UNC		26 (1.02")	52.4 (2.06")	26.2 (1.03")		



BI-DIRECTIONAL PUMPS Special version available on request.

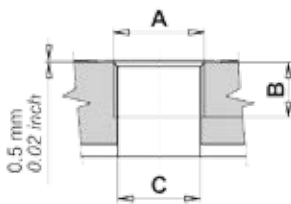

**code G**

Threaded ports  
GAS (BSPP)

UNI-DIRECTIONAL PUMPS	TYPE	INLET			OUTLET		
		A	B	C	A	B	C
	From 21 to 38	G1	22 (0.86")	27 (1.06")	G1	22 (0.86")	27 (1.06")
	From 46 to 75	G1 1/4	24 (0.94")	32.5 (1.28")			



BI-DIRECTIONAL PUMPS Special version available on request.

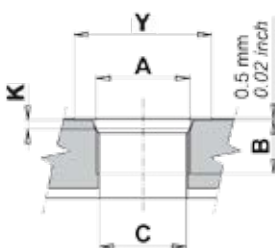

**code R**

Threaded ports  
SAE (ODT)

UNI-DIRECTIONAL PUMPS	TYPE	INLET					OUTLET				
		A	B	C	Y	K	A	B	C	Y	K
	From 21 to 38	1-5/16-12 UN (SAE 16)	19 (0.75")	25 (0.98")	49 (1.93")	3.3 (0.12")	1-1/16-12 UN (SAE 12)	19 (0.75")	21 (0.83")	41 (1.16")	3.3 (0.13")
	From 46 to 75	1-5/8-12 UN (SAE 20)		27 (1.06")	58 (2.28")		1-5/16-12 UN (SAE 16)		25 (0.98")	49 (1.93")	



BI-DIRECTIONAL PUMPS Special version available on request.

EO.130.0416.02.001M02



DRIVE SHAFTS

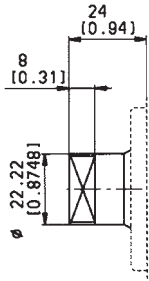

**code 05** Max torque 180 Nm (1590 lbf in)  
Tang drive for electric motors

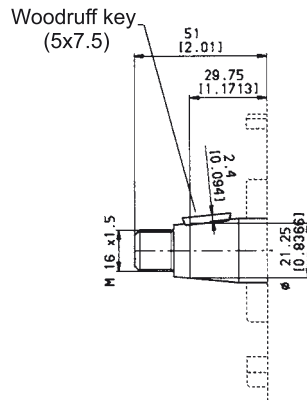

**code 35** Max torque 260 Nm (2300 lbf in)  
European tapered 1:5



**code 38** Max torque 250 Nm (2213 lbf in)  
European tapered 1:8

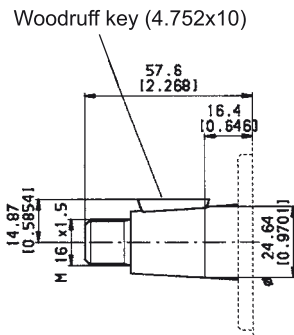

**code 48** Max torque 350 Nm (3100 lbf in)  
European tapered 1:8 for 3.5PC

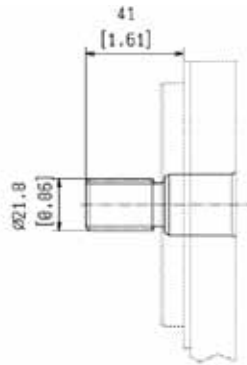

**code 55** Max torque 330 Nm (2921 lbf in)  
SAE B 13T-16/32DP Ansi B92 1a 1976

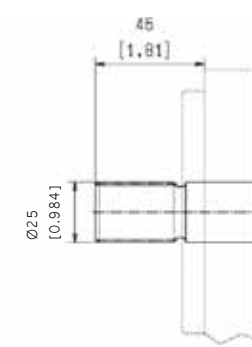

**code 56** Max torque 480 Nm (4250 lbf in)  
SAE BB 15T-16/32DP Ansi B92 1a 1976

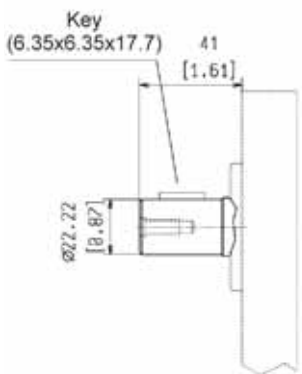

**code 87** Max torque 220 Nm (1950 lbf in)  
SAE B Parallel

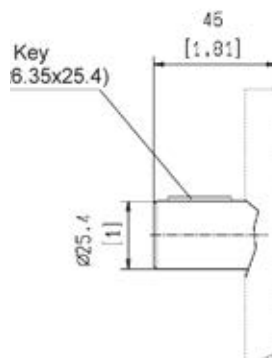

**code 88** Max torque 320 Nm (2830 lbf in)  
SAE BB Parallel

E0.130.0416.02.00IM02



**MOUNTING FLANGES**

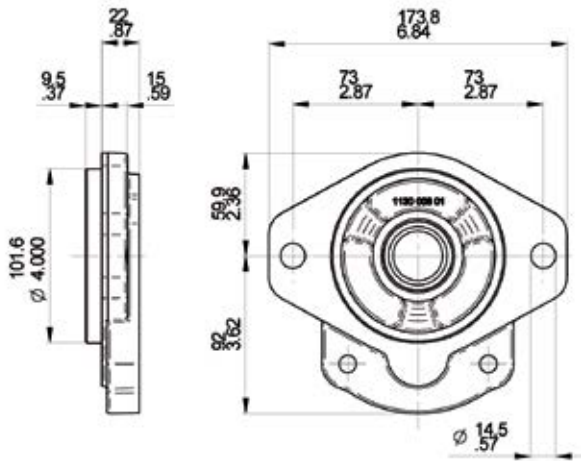

<b>S3</b>	<b>SAE B 2 Bolts</b>
With shaft code 55-56-87-88	

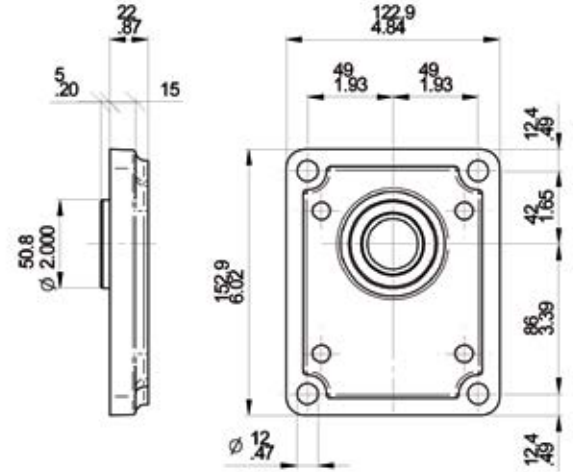

<b>P2</b>	<b>European standard</b>
With shaft code 38	

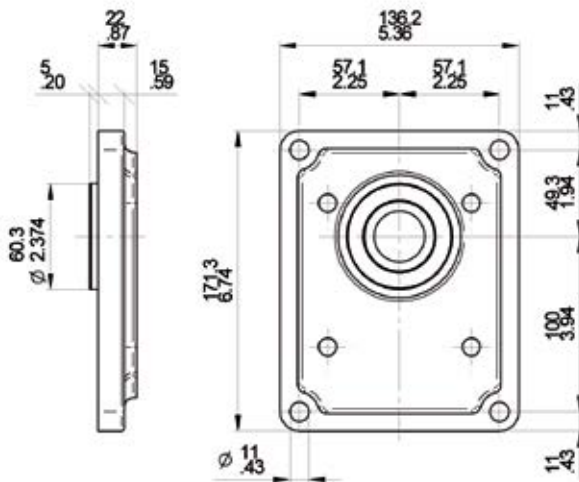

<b>P3</b>	<b>European standard for 3.5PC</b>
With shaft code 48	

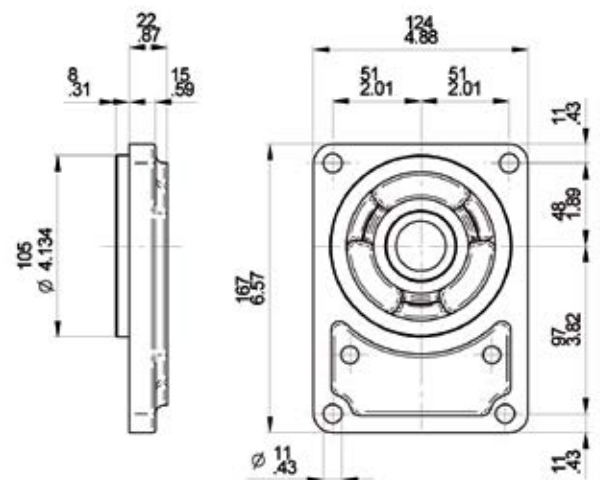

<b>B6</b>	<b>German standard</b>
With shaft code 05-35	

EO.130.0416.02.001M02





### OUTRIGGER BEARING

The following diagrams show radial load capability of the bearing.

Calculation according to ISO 281 at 10 cSt.

TYPE	H
27	79 (3.11")
33	84 (3.31")
38	88 (3.46")
46	104 (4.09")
55	110 (4.33")
65	117 (4.61")

L=Distance between mounting flange and radial force point of application.

Example:  
Fr = 3000 N → Expected life: 1000 hrs  
L = 35  
Speed = 2500 rpm

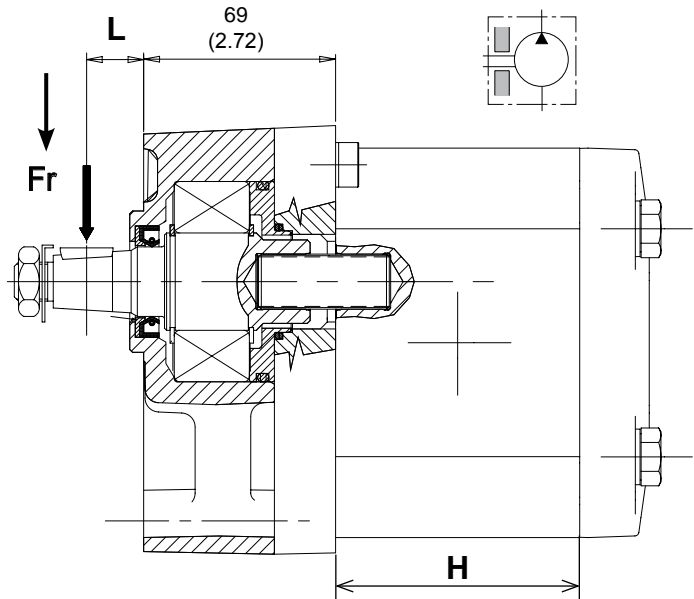

For Code CP

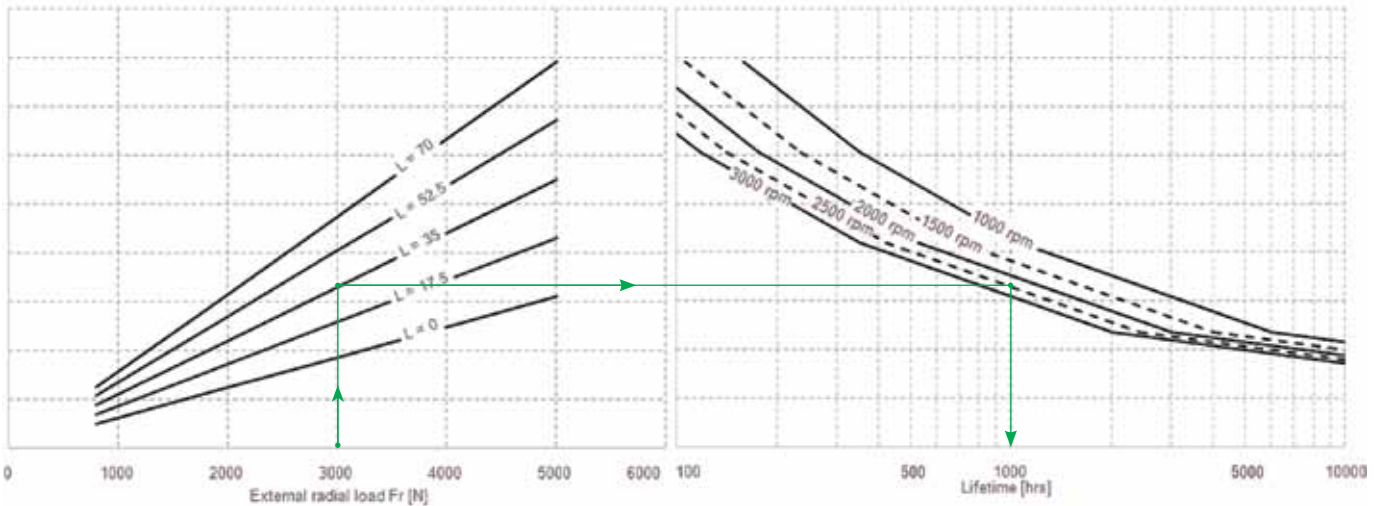

For Code CSB

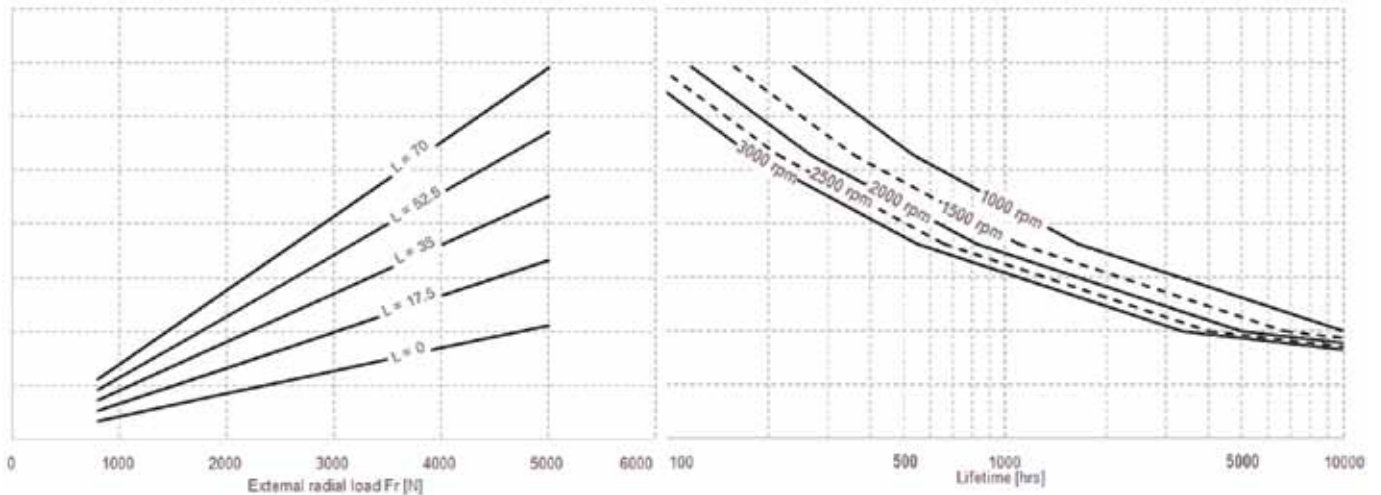

E0.130.0416.02.00IM02



**MOUNTING FLANGES WITH OUTRIGGER BEARING SUPPORT**

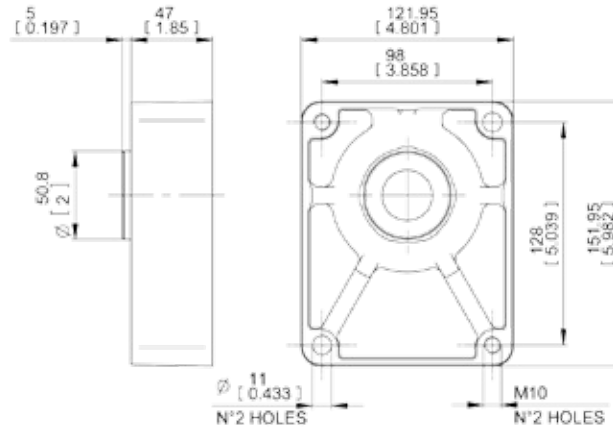

<b>CP</b>	<b>European standard Ø50.8 mm</b>
With shaft code 38	

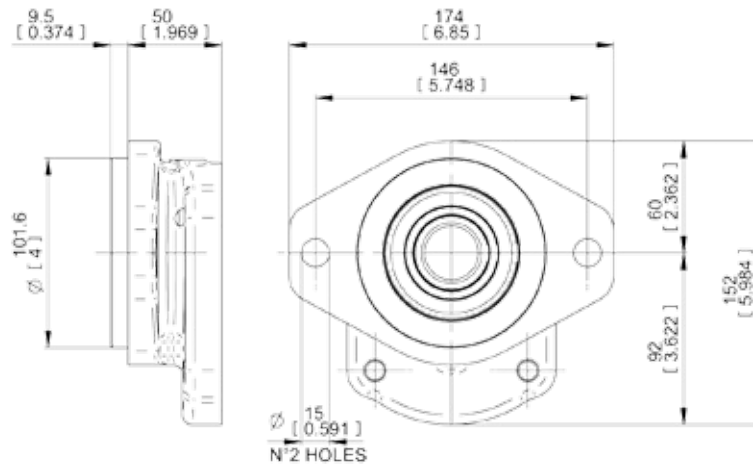

<b>CSB</b>	<b>SAE B</b>
With shaft code 55-56-87-88	

EO.130.0416.02.001M02



REAR COVER

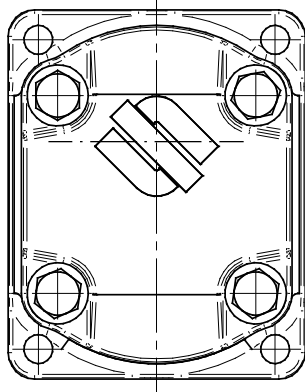

Standard rear cover for unidirectional pumps

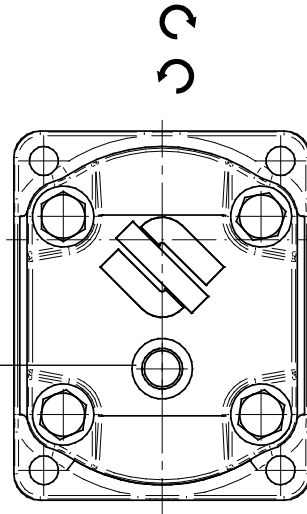

external drain  
DIMENSION C

Standard rear cover for reversible pumps, with external drain C.  
For the dimension C please see the table here below

C
G3/8
9/16-18 UNF-2B (SAE6)

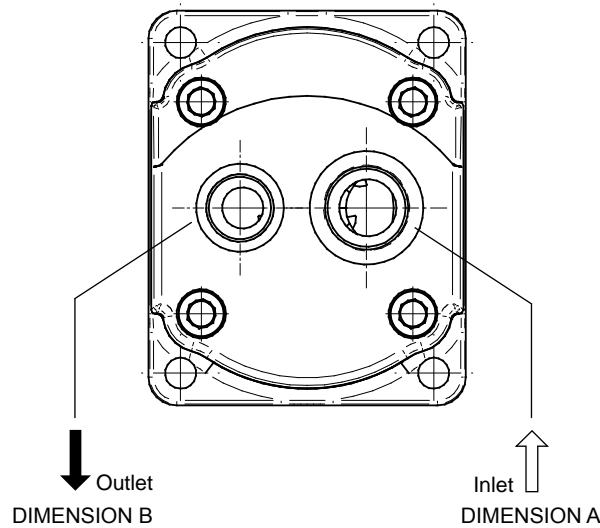

code 1

For pumps with threaded rear ports, suitable up to 80 l/min delivery.

A	B
G1	G3/4
1-5/16-12 UN-2B (SAE16)	1-1/16-12 UN-2B (SAE12)

E0.130.0416.02.00IM02



PRIORITY VALVES

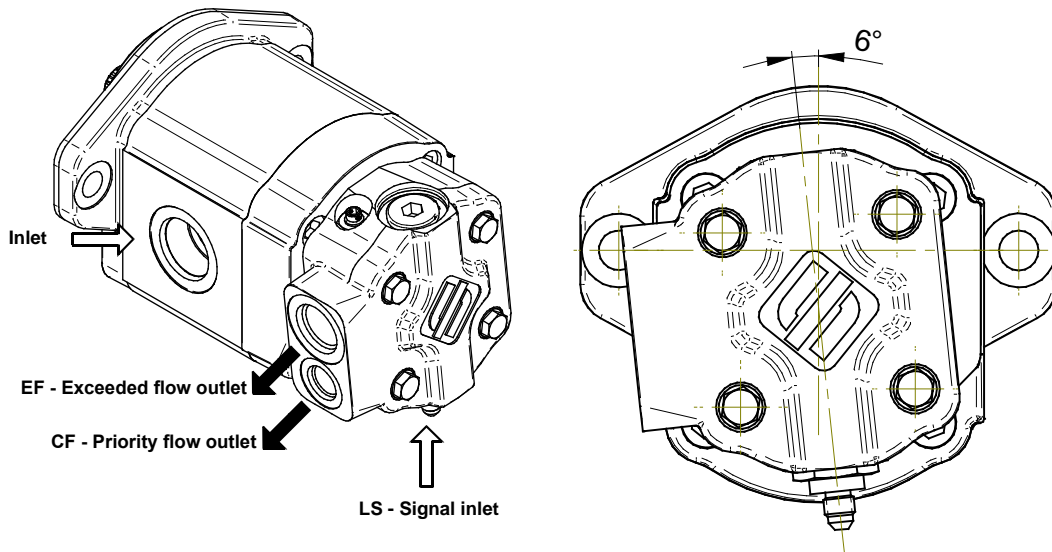

The double or triple pumps can be configured with priority flow valve too.  
The stage which has its flow divided into priority and exceeded flows is always the back one.

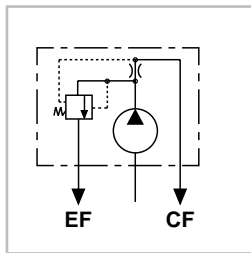

code VP1

Priority flow valve, excess flow to second actuator.

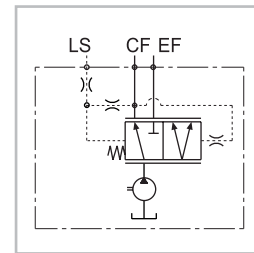

code VPD1

Load sensing priority valve with dynamic signal without main relief valve.

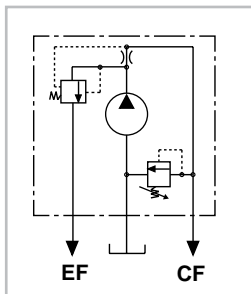

code VPS1

Priority flow valve, excess flow to second actuator with pressure relief valve on priority flow line.

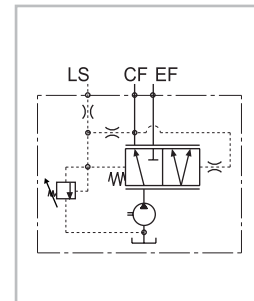

code VPDS1

Load sensing priority valve with dynamic signal with main relief valve.

CF = Priority flow port  
EF = Excess flow port  
LS = Load sensing signal port

EO.130.0416.02.001M02



### VP1 - VPS1 SIDE PORTS

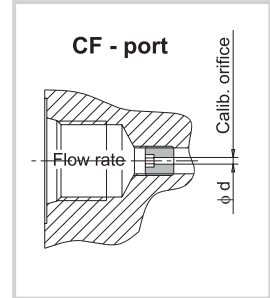
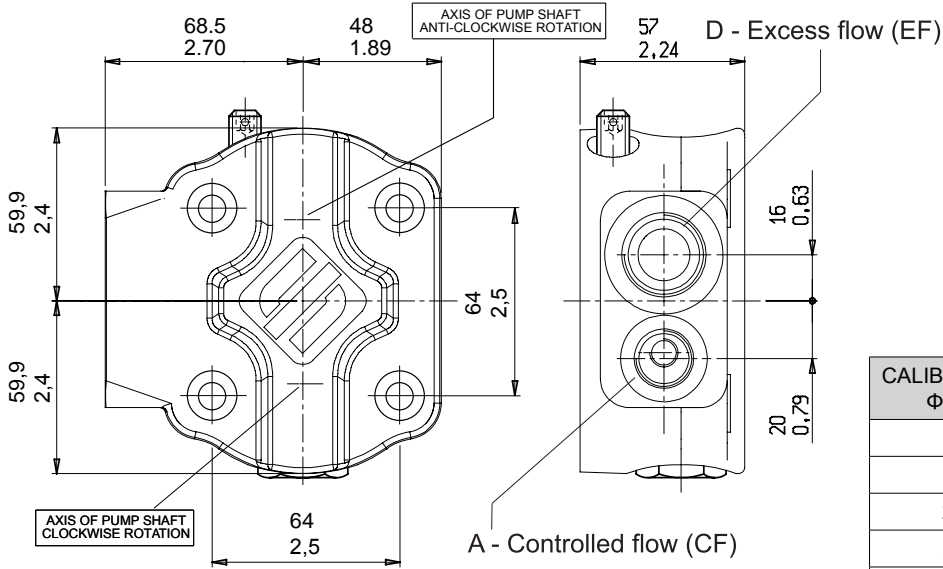

CALIBRATED ORIFICE $\Phi d$ (mm/inch)	FLOW RATE (l/min - gpm) $\pm 10\%$
1.5 / (0.06")	2.5 - (0.66)
2 / (0.08")	4 - (1.06)
2.4 / (0.09")	6 - (1.59)
2.8 / (0.11")	8 - (2.11)
3.1 / (0.12")	10 - (2.64)
3.5 / (0.14")	12.5 - (3.30)
4 / (0.16")	16 - (4.23)
4.4 / (0.17")	20 - (5.28)
4.9 / (0.19")	25 - (6.61)

### VPD1 - VPDS1 SIDE PORTS

A	D
G 3/8	G 3/4
SAE8 3/4-16 UNF-2B	SAE12 1 1/16 - 12 UN - 2B

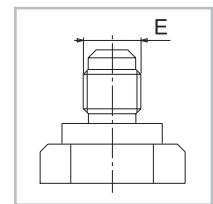
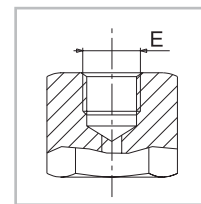
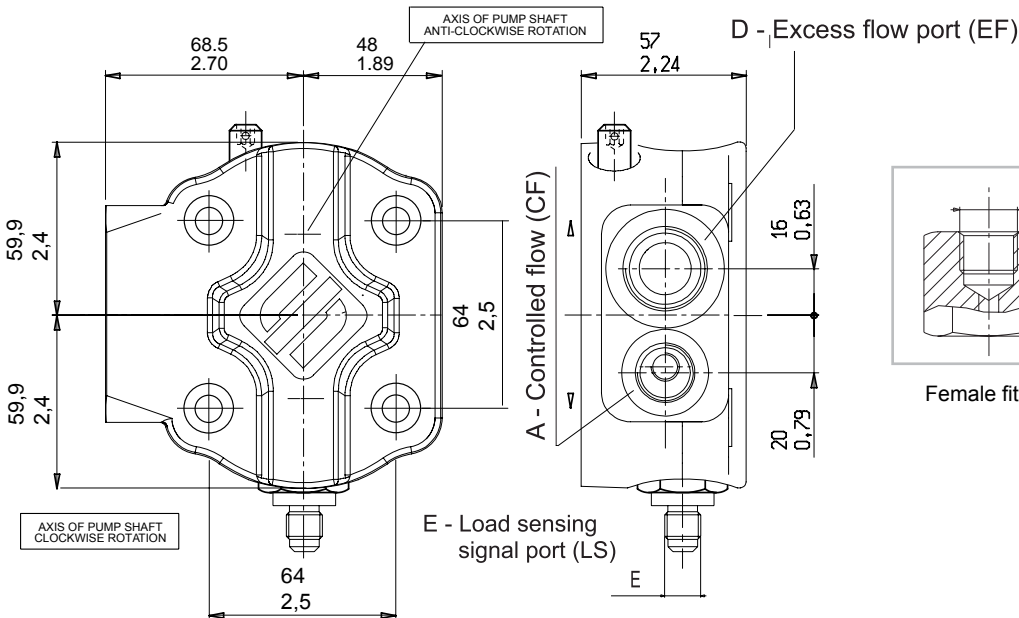

Female fitting

Male fitting

Minimum load sensing signal  
(LS) = 4 bar (28 psi)

A	D	E
G 3/8	G 3/4	G 1/4
SAE8 3/4 - 16 UNF - 2B	SAE12 1-1/16 - 12 UN - 2B	SAE4 7/16 - 20 UNF - 2B

E0.130.0416.02.00IM02



**MULTIPLE GEAR PUMPS  
ASSEMBLING DIMENSIONS**

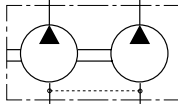

**MULTIPLE  
GEAR PUMPS  
with inlet port  
on each body**

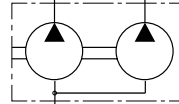

**MULTIPLE  
GEAR PUMPS  
with common  
inlet port\***

\*In case of common inlet port, to avoid too high value of oil speed, 60 l/min is the max sucked flow for the downstream pump.

Type		21*	27	33	38	46	55	65	75*
Displacement	cm <sup>3</sup> /rev	20.6	27	33.5	38.7	46.9	54.1	63.1	73.4
	cu.in./rev	1.26	1.65	2.04	2.36	2.86	3.3	3.85	4.48
Dimension A	mm	74	79	84	88	104	110	117	124
	in	2.91	3.11	3.31	3.46	4.09	4.33	4.61	4.88
Dimension C	mm	37	39.5	42	44	52	55	58.5	62
	in	1.46	1.56	1.65	1.73	2.05	2.17	2.30	2.44

\*Displacements 21 and 75 are special release, please contact sales department.

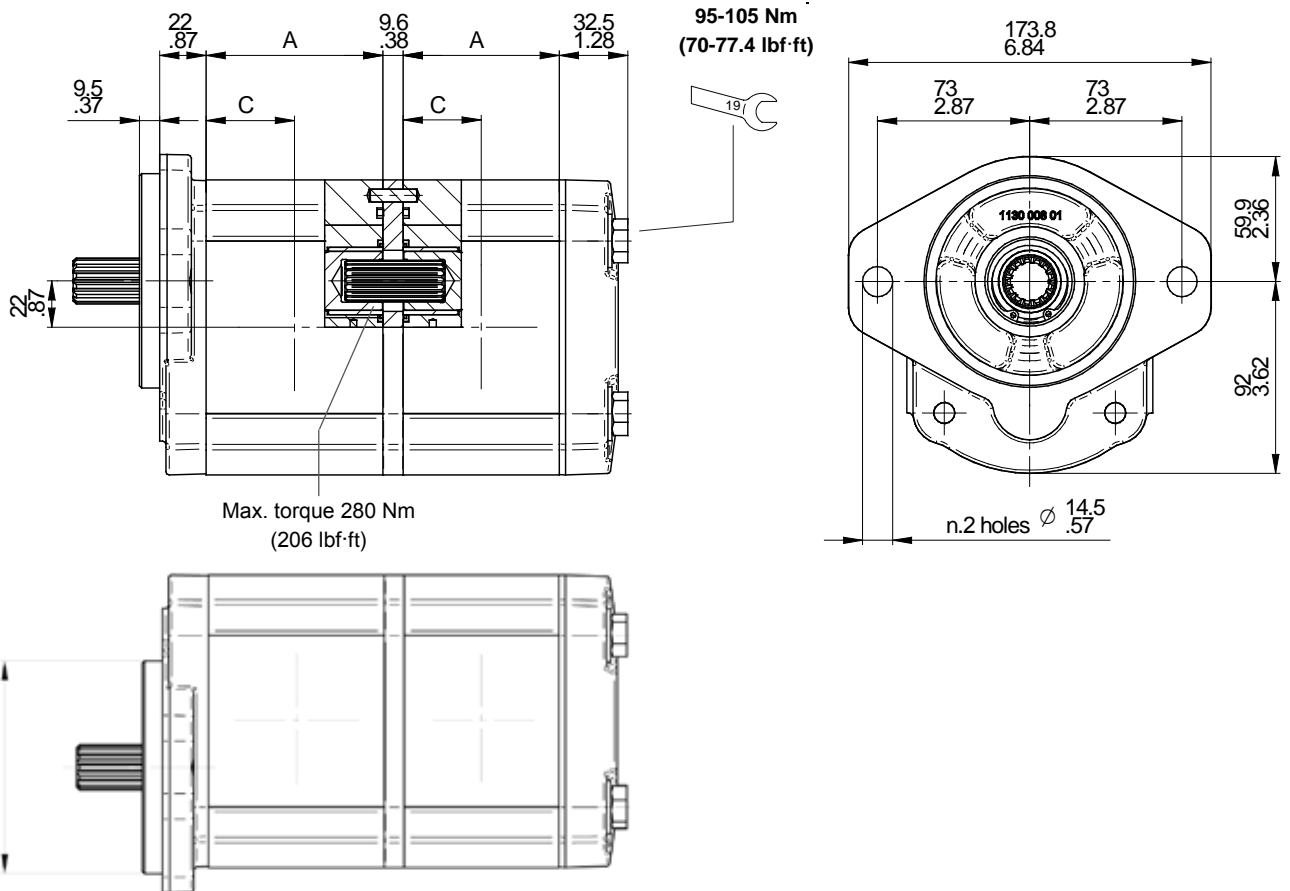

EO.130.0416.02.001M02



### 3PE COMBINATION WITH PUMP 2PE

ALL THE PUMPS CAN BE ALSO MULTIPLE

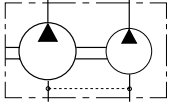

**MULTIPLE GEAR PUMPS with inlet port on each body**

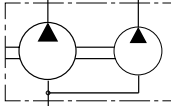

**MULTIPLE GEAR PUMPS with common inlet port\***

\*In case of common inlet port, to avoid too high value of oil speed, 30 l/min is the max sucked flow for the downstream pump or pumps.

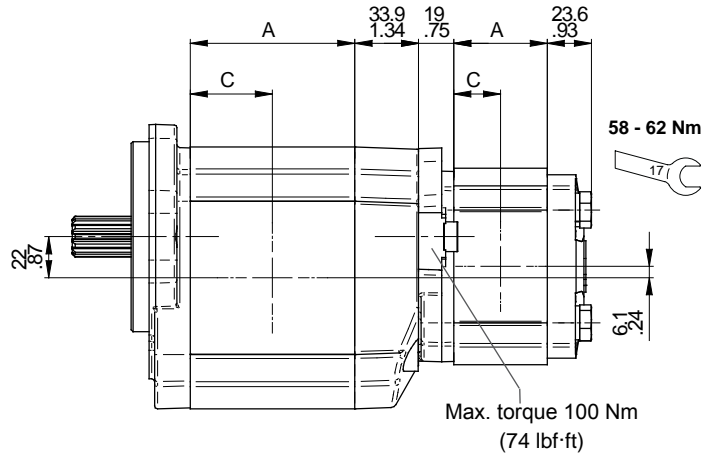

3PE dimensions A and C are available at the previous page.

2PE-Type		3.2*	3.9*	4.5	6.5	8.3	10.5	11.3	12.5	13.8	16	19	22.5	26
Dimension A	mm		47.1		49.95	52.8	56.3	59.7	63.5	67.5	75.6	81	86.8	
	in		1.83		1.97	2.07	2.22	2.35	2.5	2.65	2.97	3.19	3.42	
Dimension C	mm		23.55		25	26.4	28.15	29.75	31.75	33.75	37.80	40.5	43.4	
	in		0.93		0.98	1.04	1.11	1.17	1.25	1.33	1.49	1.59	1.71	

\*Available only as rear pump

### 3PE COMBINATION WITH PUMP 1.5PE

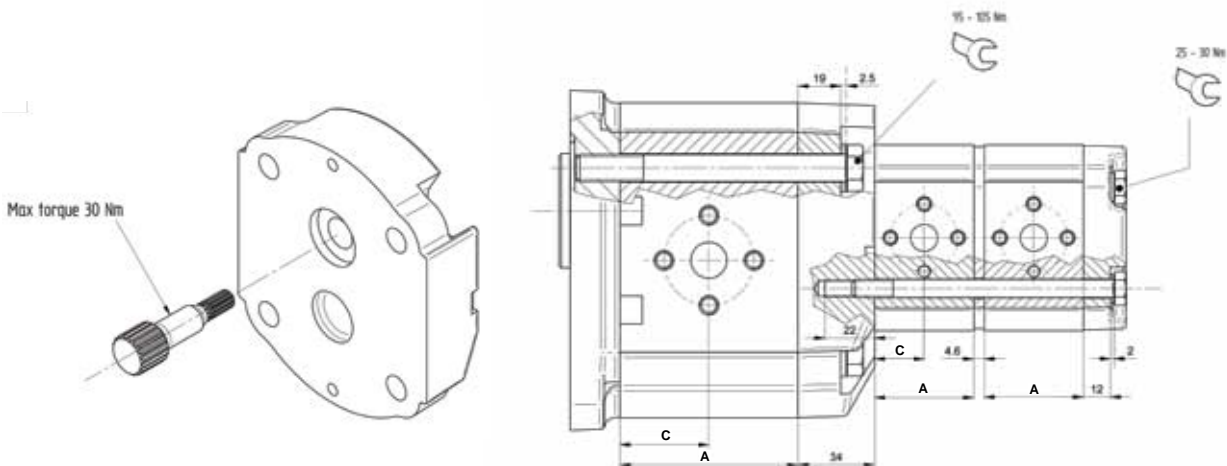

1.5PE-Type		1.4	2.1	2.8	3.5	4.1	5.2	6.2	7.6	9.3	11
Dimension A	mm	44	45.9	47.9	49.9	51.6	54.7	57.5	61.5	66.3	71.1
	in	1.73	1.81	1.89	1.96	2.03	2.15	2.26	2.42	2.61	2.80
Dimension C	mm	22	22.95	23.95	24.95	25.8	27.35	28.75	30.75	33.15	35.55
	in	0.87	0.90	0.94	0.98	1.02	1.08	1.13	1.21	1.31	1.40

E0.130.0416.02.00IM02



**PERFORMANCE CURVES**

Performance curves carried out with oil viscosity at 21 cSt and oil temperature at 50°C

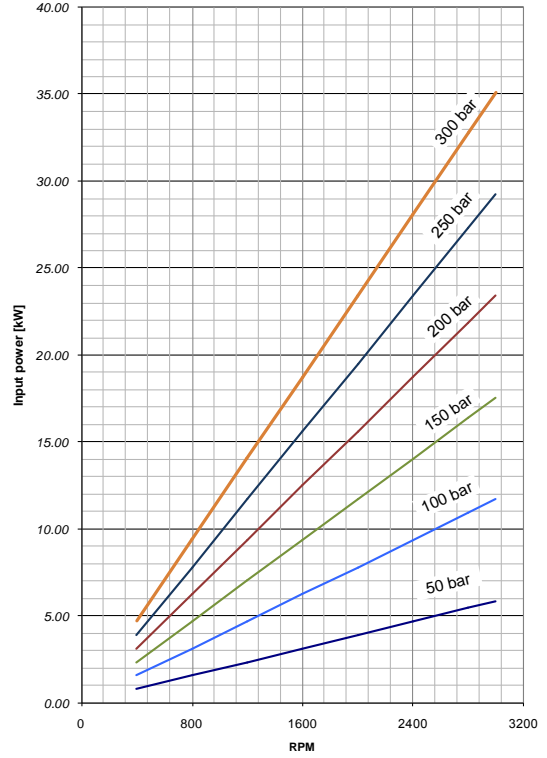
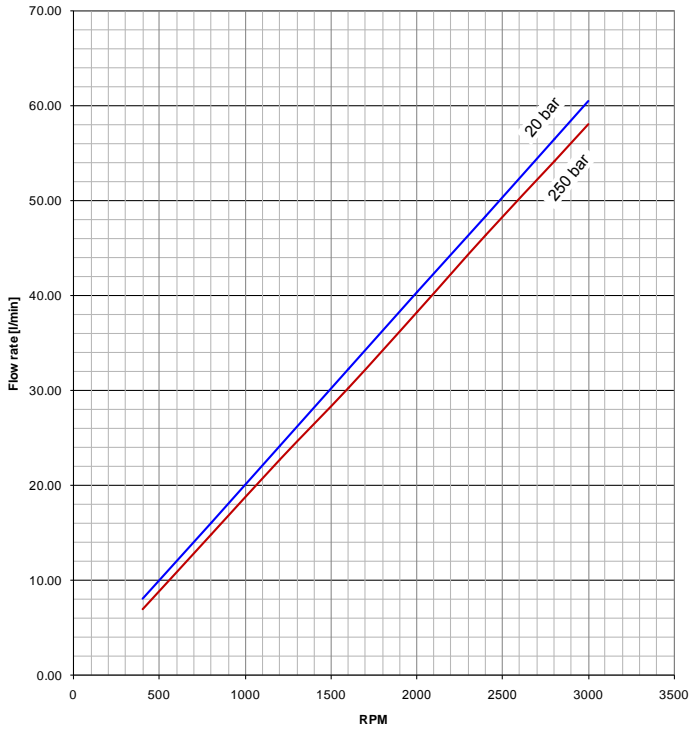

**3PE-21**

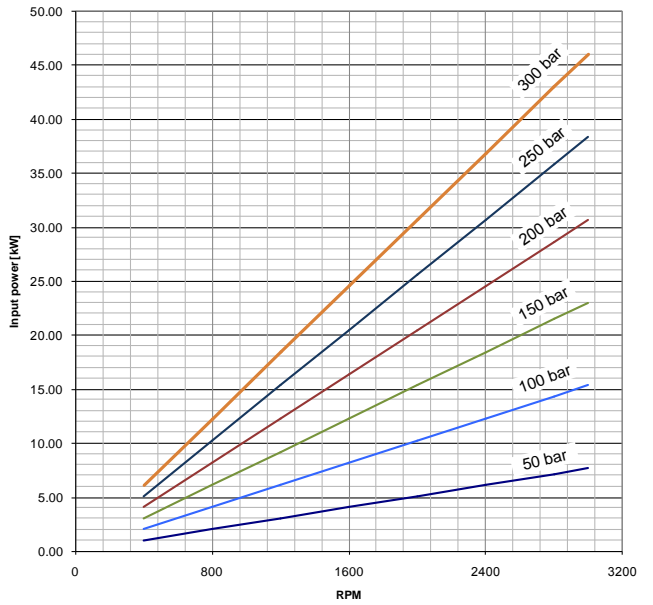
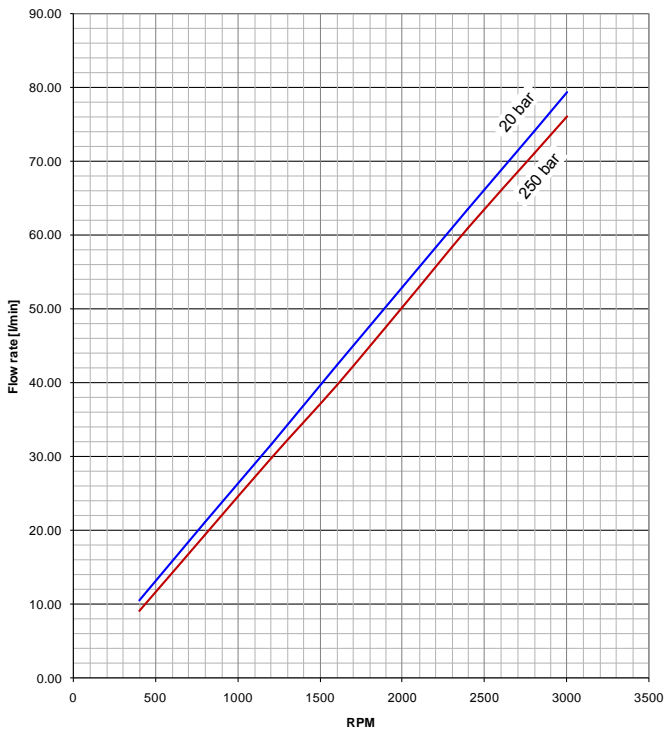

**3PE-27**

EO.130.0416.02.001M02





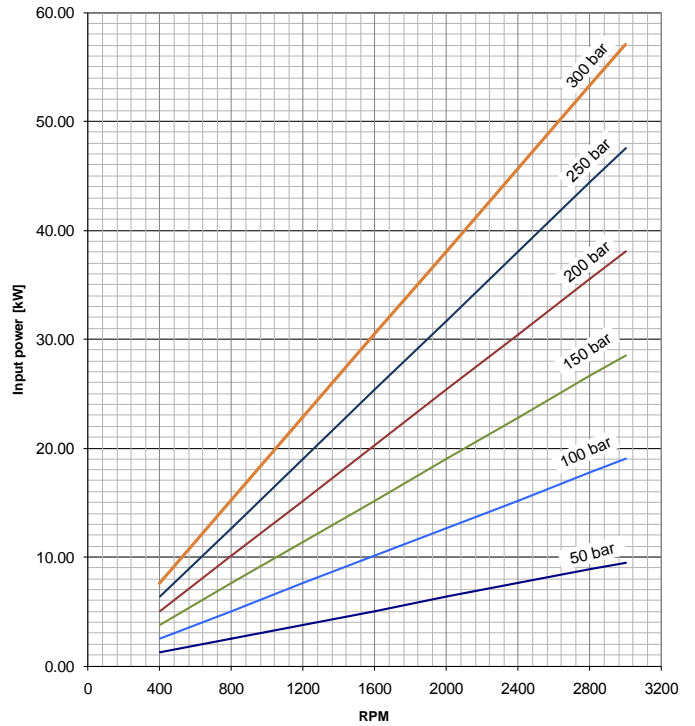
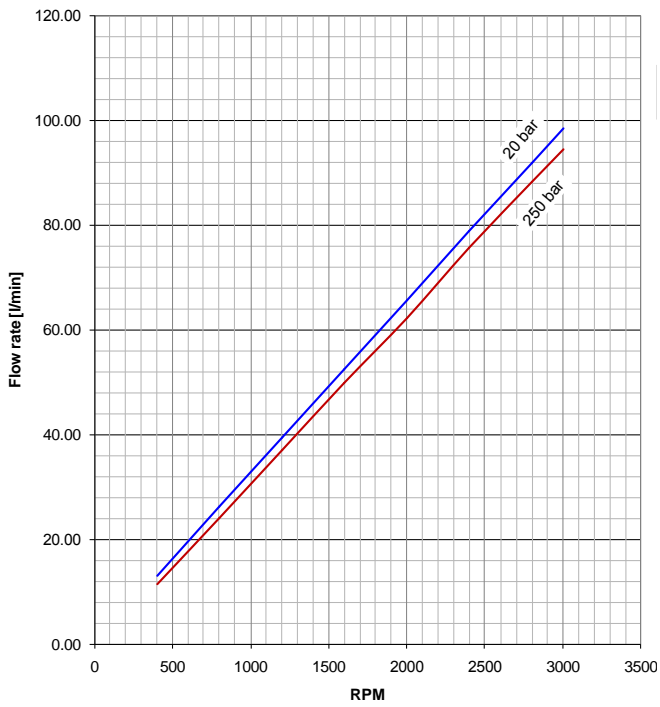

3PE-33

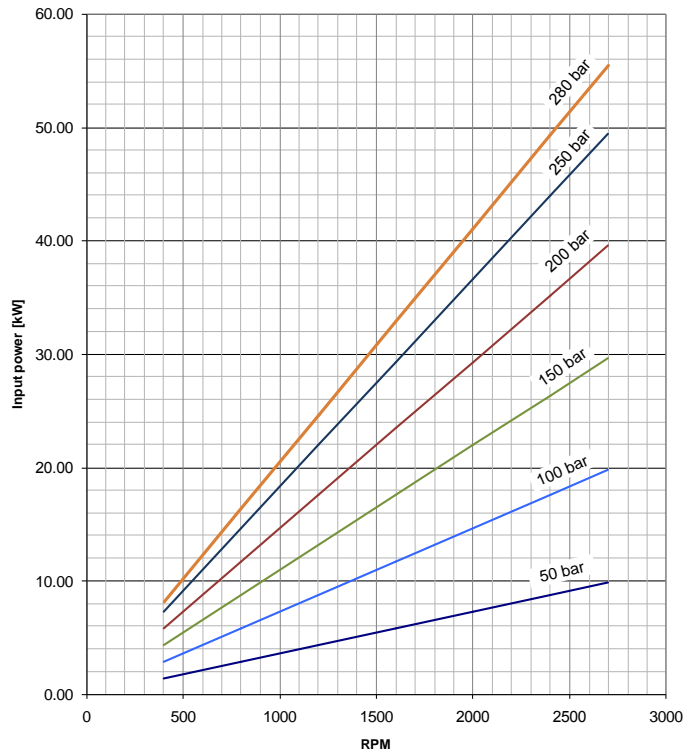
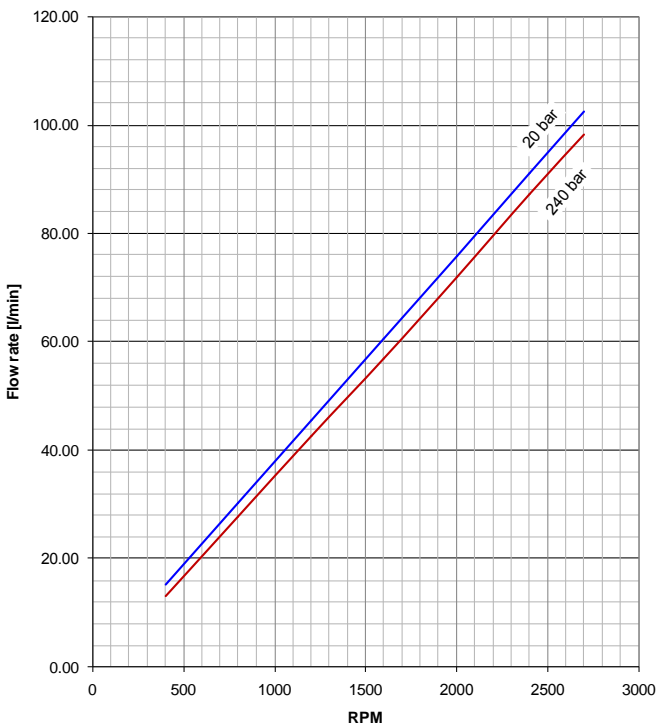

3PE-38

E0.130.0416.02.00IM02



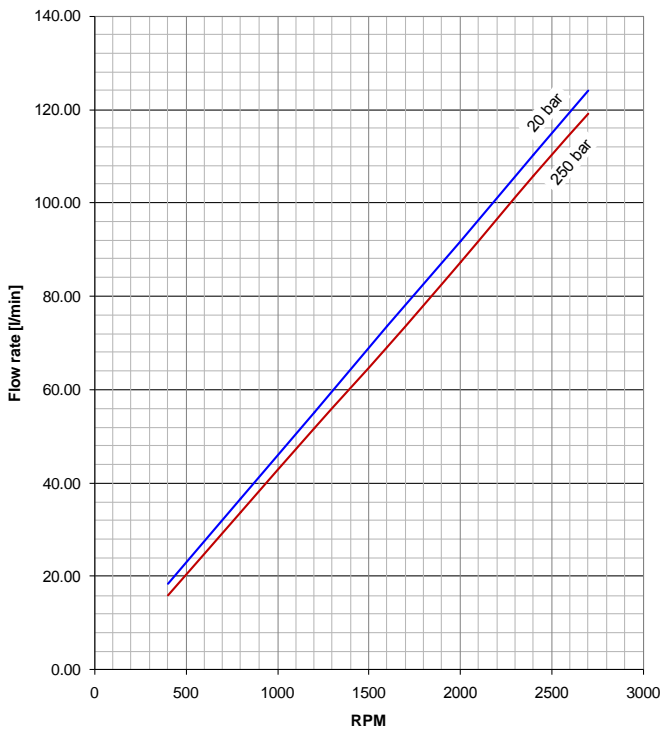

**3PE-46**

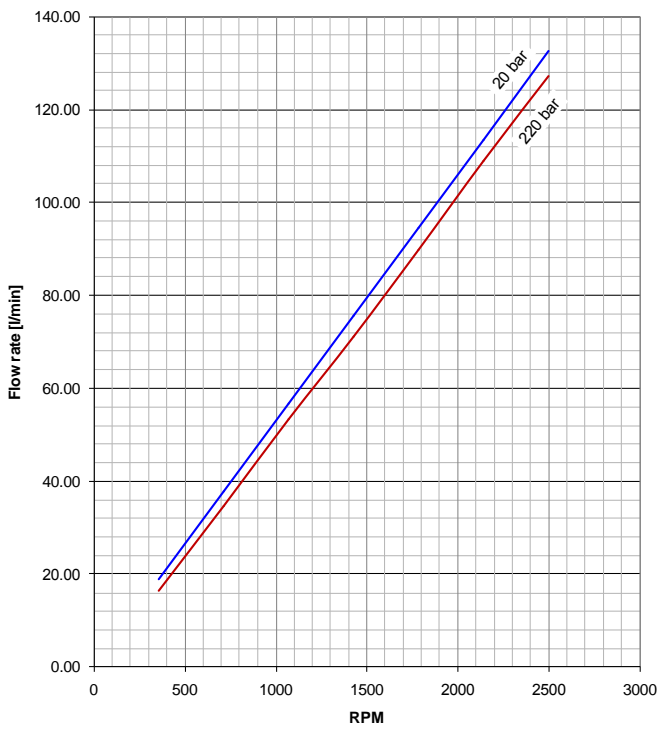
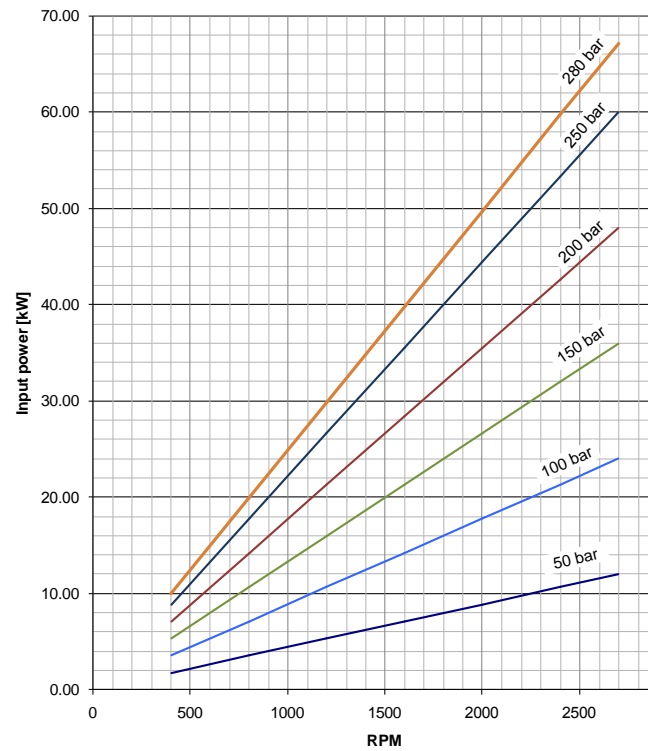

**3PE-55**

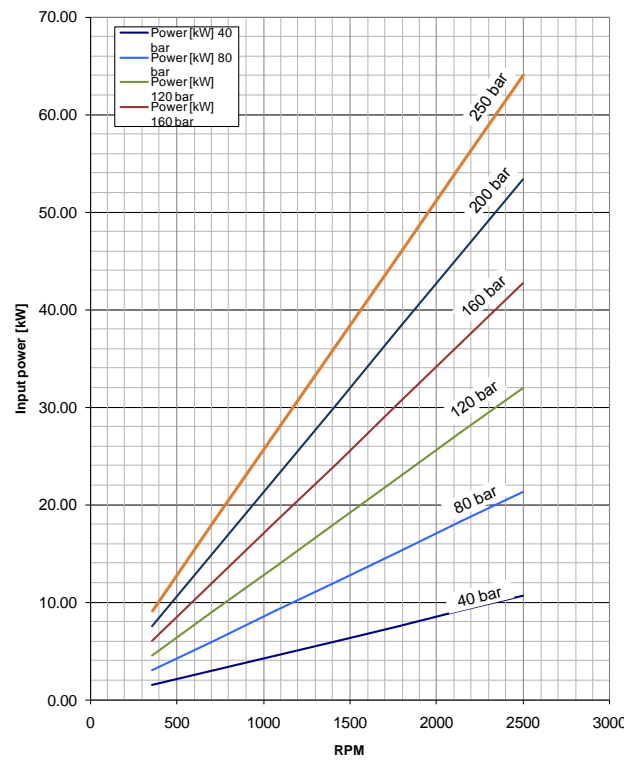

EO.130.0416.02.001M02



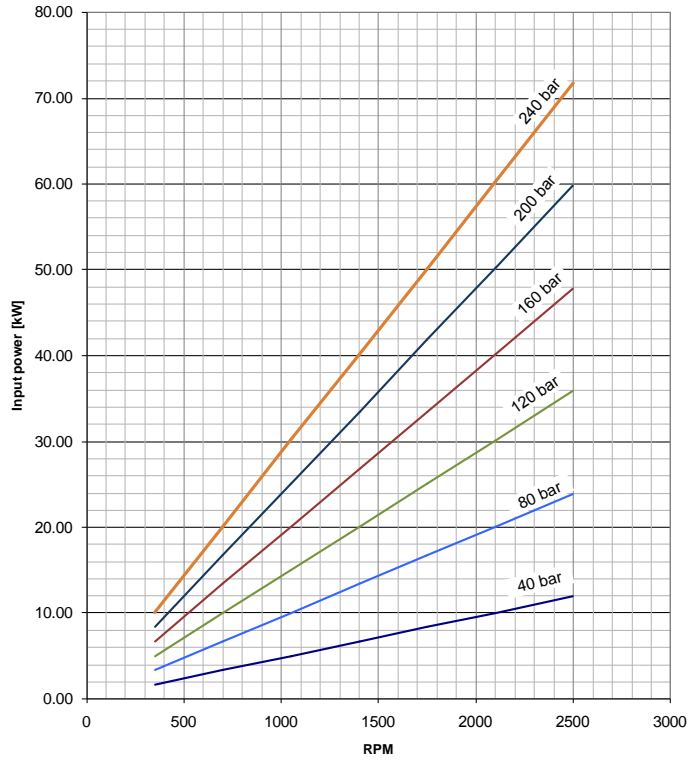
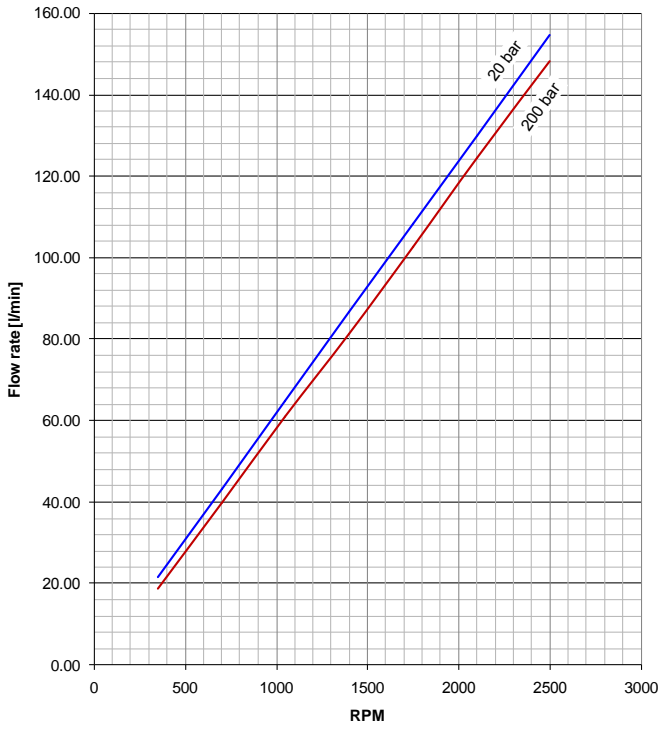

3PE-65

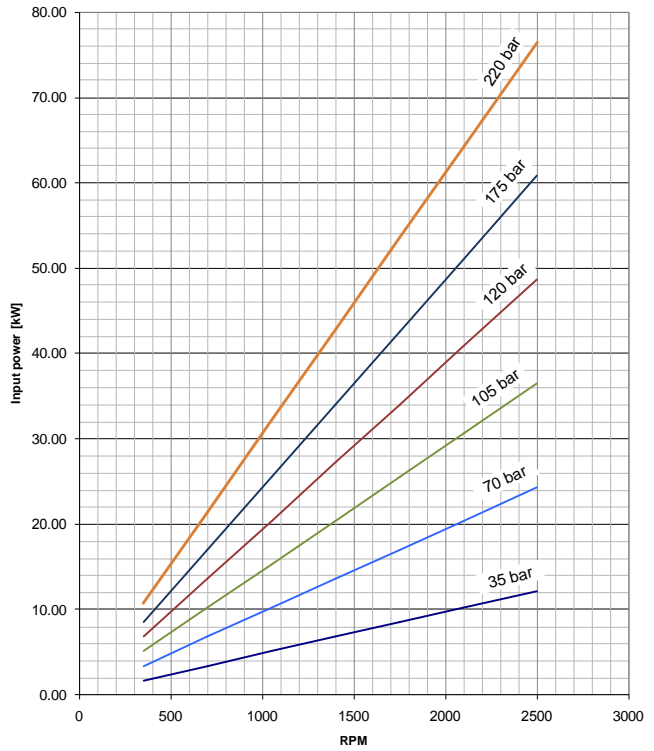
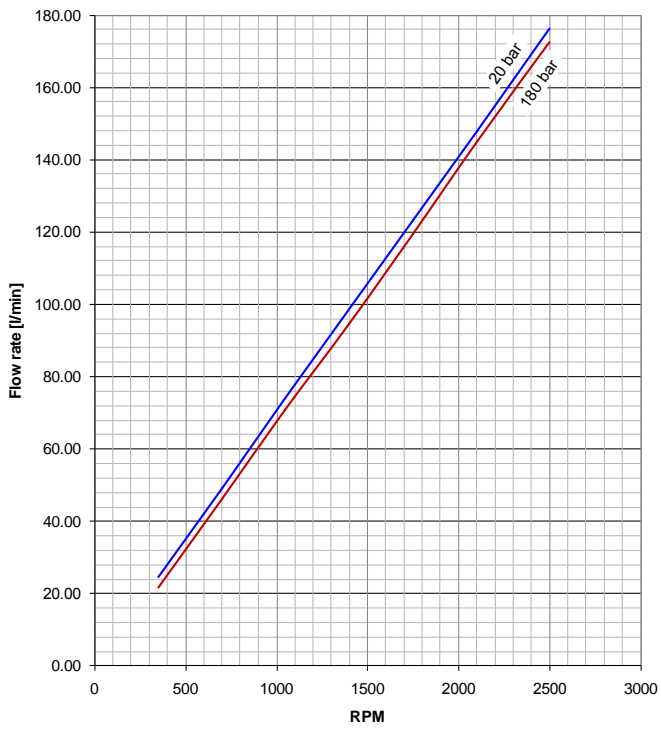

3PE-75

E0.130.0416.02.00IM02



**SINGLE PUMPS**

3PE   
 A 33   
 B D -   
 C P 38 P2 -   
 E P2 -   
 F V -   
 G 1 -   
 H CP -   
 I PD2 -   
 L VP1   
 ...   
 /   
 ...

TYPE	A	DISPLACEMENTS	
21		20.6 cm <sup>3</sup> /rev.	1.26 cu.in./rev.
27		27 cm <sup>3</sup> /rev.	1.65 cu.in./rev.
33		33.5 cm <sup>3</sup> /rev.	2.04 cu.in./rev.
38		38.7 cm <sup>3</sup> /rev.	2.36 cu.in./rev.
46		46.9 cm <sup>3</sup> /rev.	2.86 cu.in./rev.
55		54.1 cm <sup>3</sup> /rev.	3.3 cu.in./rev.
65		63.1 cm <sup>3</sup> /rev.	3.85 cu.in./rev.
75		73.4 cm <sup>3</sup> /rev.	4.48 cu.in./rev.

ROTATION (page 4)	CODES	B
Clockwise	D	
Anti-clockwise	S	
Reversible	R	

PORTS (page 88)	CODES	C
Flanged ports european standard	P	
Flanged ports german standard	B	
Threaded ports GAS (BSPP)	G	
Threaded ports SAE (ODT)	R	
Flanged ports SAE J518 AMERICAN STANDARD THREAD	S	
Flanged ports SAE J518 METRIC THREAD	W	

DRIVE SHAFT (page 90)	CODES	D
Tang drive for electric motors	05	
European Tapered 1:5	35	
European Tapered 1:8	38	
European Tapered 1:8	48	
SAE B splined 13T	55	
SAE BB splined 15T	56	
SAE B parallel	87	
SAE BB parallel	88	

L VALVES IN THE COVER (page 95)	CODES
Priority flow divider with excess flow to 2nd actuator	VP1
Like VP with main relief valve	VPS1
Priority flow divider with Load sensing with dynamic signal	VPD1
Load sensing priority valve with dynamic signal with main relief valve	VPDS1

I REAR COVER (page 98)	CODE
Pre-arranged for 1.5PE rear	PD1.5
Pre-arranged for 2PE rear	PD2

H OUTRIGGER BEARING (page 92)	CODES
European standard	CP
German standard	CSB

G PORTS POSITION	CODE
Lateral ports standard	
Rear ports (page)	1

F SEAL	CODE
Buna standard	
Viton	V

E MOUNTING FLANGES (page 91)	CODES
SAE B 2 Bolts	S3
European standard Ø50.8	P2
European standard Ø60.3	P3
German standard Ø105	B6

Adjustable flow l/min

Setting main relief valve (bar)

EO.130.0416.02.001M02

Order example 3PE 46D, ports SAE (R), drive shaft (56), mounting flange (S3)  
**3PE46D-R56S3**



### MULTIPLE PUMPS

TYPE	A	DISPLACEMENTS		B	C	D	E	F	G	H	I	L	M
3PE	65 / 46	D	P	28	P2	V	UA	1	CP	PD2	VPD1	Adjustable flow l/min	Setting main relief valve (bar)
<b>ROTATION (page 4)</b>		<b>CODES</b>		<b>B</b>									
Clockwise		D											
Anti-clockwise		S											
<b>PORTS (page 88)</b>		<b>CODES</b>		<b>C</b>									
Flanged ports european standard		P											
Flanged ports german standard		B											
Threaded ports GAS (BSPP)		G											
Threaded ports SAE (ODT)		R											
Flanged ports SAE J518 AMERICAN STANDARD THREAD		S											
Flanged ports SAE J518 METRIC THREAD		W											
<b>DRIVE SHAFT (page 90)</b>		<b>CODES</b>		<b>D</b>									
Tang drive for electric motors		05											
European Tapered 1:5		35											
European Tapered 1:8		38											
European Tapered 1:8		48											
SAE B splined 13T		55											
SAE BB splined 15T		56											
SAE B parallel		87											
SAE BB parallel		88											
<b>M VALVES IN THE COVER (page 95)</b>		<b>CODES</b>											
Priority flow divider with excess flow to 2nd actuator		VP1											
Like VP with main relief valve		VPS1											
Priority flow divider with Load sensing with dynamic signal		VPD1											
Load sensing priority valve with dynamic signal with main relief valve		VPDS1											
<b>L REAR COVER (page 98)</b>		<b>CODE</b>											
Pre-arranged for 1.5PE rear		PD1.5											
Pre-arranged for 2PE rear		PD2											
<b>I OUTRIGGER BEARING (page 92)</b>		<b>CODES</b>											
European standard		CP											
German standard		CSB											
<b>H PORTS POSITION</b>		<b>CODE</b>											
Lateral ports standard													
Rear ports (page)		1											
<b>G SUCTION PORTS</b>		<b>CODES</b>											
Common suction		UA*											
Separated stages		AS											
<b>F SEAL</b>		<b>CODE</b>											
Buna standard													
Viton		V											
<b>E MOUNTING FLANGES (page 91)</b>		<b>CODES</b>											
SAE B 2 Bolts		S3											
European standard Ø50.8		P2											
European standard Ø60.3		P3											
German standard Ø105		B6											

Order example 3PE 33/27D, ports SAE (P), drive shaft (56), mounting flange (S3)  
**3PE33/27D-R56S3**

\*UA: this type of multiple pump is a Salami standard multiple pump which has only one inlet port opened, all the other inlet port are closed.  
In case of common suction, the code 1 - 2 or 3, correspond to the body where inlet is located.

E0.130.0416.02.00IM02



**You can find our most up to date “STANDARD SALES CONDITIONS” on our website.**

**Potete trovare le nostre più aggiornate “CONDIZIONI DI VENDITA STANDARD” sul nostro sito.**

**www.salami.it**

**T. +39 059 387 411**

**sales@salami.it**

Watch our tutorials on youtube channel



Salami Fluid Power  
Salami Fluid Power World  
Salami Fluid Power France  
Salami Fluid Power España  
Salami Fluid Power Deutsch



**SALAMI S.P.A.**

Via Emilia Ovest 1006  
41121 Modena (Italy)  
T. +39 059 387 411  
F. +39 059 387 639  
sales@salami.it

**SALAMI ESPAÑA**

Poligono Industrial Armenteres  
C/Primer de Maig, 18, Nave 4  
08980 San Feliu de Llobregat  
Barcelona  
T. +34-93-6327288  
F. +34-93-6667826  
info@salamispain.com

**SALAMI FRANCE**

22, rue Louis Saillant  
69120 Valux en Velin  
Lyon  
T. +33-04-78809941  
F. +33-04-78804264  
e.pasian@salami.fr

**SALAMI HYDRAULICS N.A INC**

Loop Road  
Baldwinsville  
NY 13027 - USA  
T. +1-315-295-2363  
F. +1-315-295-2364  
info@salamihydraulics.com