

Feed Control Valves

These valves are the combination of flow control valve, a deceleration valve and a check valve and used mainly for controlling rapid traverse and feed cycles machine tools. Switching from rapid traverse to feed is made by a cam operation, and fine feed control is accomplished by dial rotation regardless of pressure and oil temperature variation. Rapid return is free of cam actuation.

Specifications

Model Numbers	Max. Flow ^{★1} L/min (U.S.GPM)	Metred Flow Range L/min (U.S.GPM)		Max. Reversed Free Flow L/min (U.S.GPM)	Max. Operating Pressure MPa (PSI)	Approx. Mass kg (lbs.)
		Feed	Fine Feed			
UCF1G-01-4-A-*-11*	16 [12] (4.2 [3.2])	0.03-4 (.008-1.06) {0.05-4} ^{★2} ({.013-1.06})	—	20 (5.3)	14 (2030)	1.6 (3.5)
UCF1G-01-4-B-*-11*	12 [8] (3.2 [2.1])					
UCF1G-01-4-C-*-11*	8 [4] (2.1 [1.06])					
UCF1G-01-8-A-*-11*	20 [12] (5.3 [3.2])	0.03-8 (.008-2.1) {0.05-8} ^{★2} ({.013-2.1})	—	40 (10.6)	14 (2030)	2.6 (5.7)
UCF1G-01-8-B-*-11*	16 [8] (4.2 [2.1])					
UCF1G-01-8-C-*-11*	12 [4] (3.2 [1.06])					
UCF1G-03-4-*-10*	40 [40] (10.6 [10.6])	0.05-4 (.013-1.06)	—	40 (10.6)	14 (2030)	2.6 (5.7)
UCF1G-03-8-*-10*		0.05-8 (.013-2.1)	—			
UCF2G-03-4-*-10*	40 [40] (10.6 [10.6])	0.1-4 (.026-1.06)	0.05-4 (.013-1.06)	40 (10.6)	14 (2030)	2.7 (6.0)
UCF2G-03-8-*-10*		0.1-8 (.026-2.1)	0.05-4 (.013-1.06)			
UCF1G-04-30-30*	80 [40] (21.1 [10.6])	0.1-22 (.026-5.8)	—	80 (21.1)	14 (2030)	6.5 (14.3)
UCF2G-04-30-30*		0.1-22 (.026-5.8)	0.1-17 (.026-4.5)			9.2 (20.3)

★1. The maximum flow rates are values with the deceleration valve and the flow control valve fully open. The values in [] are maximum flow rates with the deceleration valve fully open and the flow control valve fully closed.

★2. The values in { } are for pressures above 7 MPa (1020 PSI).

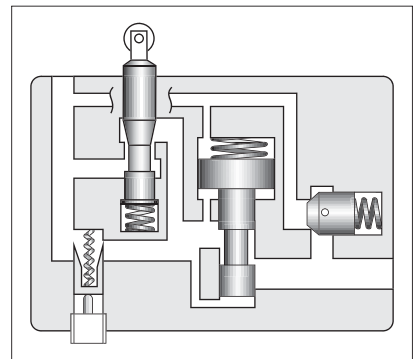

Model Number Designation

F-	UCF1	G	-01	-4	-A	-E	-11	*
Special Seals	Series Number	Type of Mounting	Valve Size	Nominal Metred Flow L/min (U.S.GPM)	Deceleration Valve Max. Flow L/min (U.S.GPM)	Drain Connection	Design Number	Design Standards
F-: Special Seals for Phosphate Ester Type Fluids (Omit if not required)	UCF1: Single Feed Control	G: Gasket Mounting	01	4: 4 (1.06) 8: 8 (2.1)	A: 12 (3.2) B: 8 (2.1) C: 4 (1.06)	None: Internal Drain E: External Drain	11	Refer to ★
			03	4: 4 (1.06) 8: 8 (2.1)	—	10		
			04	30:30 (7.9)	—	30		
	UCF2: Double Feed Control	G: Gasket Mounting	03	4: 4 (1.06) 8: 8 (2.1)	—	None: Internal Drain E: External Drain	10	
04			30:30 (7.9)	—	None: External Drain	30		

★ Design Standards: None. Japanese Standard "JIS" and European Design Standard 90. N. American Design Standard

Graphic Symbols

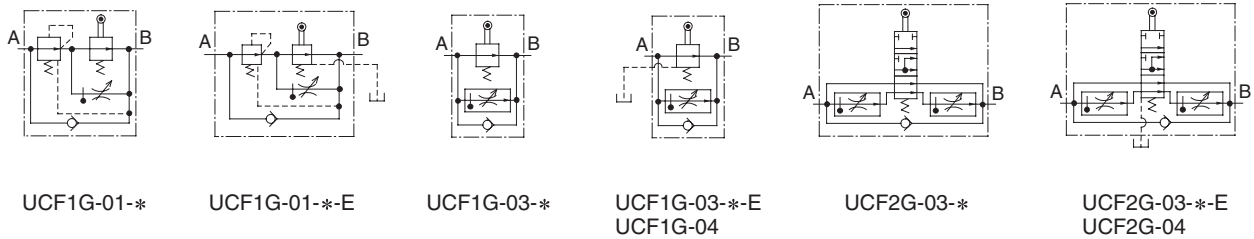

- Attachment
- Mounting Bolts

Valve Model Numbers	Socket Head Cap Screw		Qty.
	Japanese Std. "JIS" & European Design Std.	N. American Design Std.	
UCF1G-01	M6 × 55 Lg.	1/4-20 UNC × 2-1/4 Lg.	4
UCF1G-03	M6 × 55 Lg.	1/4-20 UNC × 2-1/4 Lg.	4
UCF2G-03	M6 × 55 Lg.	1/4-20 UNC × 2-1/4 Lg.	4
UCF1G-04	M10 × 70 Lg.	3/8-16 UNC × 2-3/4 Lg.	4
UCF2G-04	M10 × 70 Lg.	3/8-16 UNC × 2-3/4 Lg.	4

Instructions

- Allowable pressures at controlled flow outlet**
If internal drain types of UCF1G-01 or 03 or UCF2G-03 are used, use them in metre-out circuits in order to limit the valve outlet pressure to the valves shown below. In addition, external drain types can also be used in metre-in circuits.

Model Numbers		Allowable Outlet Port Back Pres. MPa (PSI)
Internal Drain Type	UCF1G-01-*, UCF1G-03-*, UCF2G-03-*	0.3 (44)
External Drain Type	UCF1G-01-*-E, UCF1G-03-*-E, UCF1G-04, UCF2G-03-*-E, UCF2G-04	14 (2030)

- Minimum required pressure difference**
The minimum pressure differential between inlet and outlet port is required to obtain the optimum pressure compensation. It varies accordingly to the flow rate to be set. For details, refer to the performance curve.
- Spool push down level**
Limit the spool push down level within the allowable maximum stroke range shown in the installation drawings.
- Allowable drain port back pressure**
Limit to 0.1 MPa (15 PSI).
In addition, connect the drain pipe independently and directly to the tank. (This applies only to external drain types.)

Required Force for Spool Push Down

Model Numbers	Drain Type	Force N (lbs.)
UCF1G-01	Internal drain type	100 (22.5)
	External drain type	80 (18.0)
UCF1G-03	Internal drain type	170 (38.2)
	External drain type	90 (20.2)
UCF2G-03	Internal drain type	170 (38.2)
	External drain type	130 (29.2)
UCF1G-04	External drain type	170 (38.2)
UCF2G-04	External drain type	170 (38.2)

Note: The push down forces are with the maximum allowable pressure at the port concerned, which is controlled flow outlet "B" for internal drain types or the drain port for internal drain types.

- Line filter**
To carry out flow adjustments by as small degree as 2 L/min (.53 U. S. GPM) or less, be sure to use a line filter, 10 µm or less, near the valve inlet.
- Flow adjustment**
[UCF1G-01, UCF*G-03]
Loosen the locking screw and turn the flow adjustment dial clockwise for increase, and anti-clockwise for decrease.
The dial makes about four revolutions from zero to full flow and the valve opening is indicated on the revolution indicator.
After flow adjustment, tighten the locking screw.
[UCF*G-04]
Loosen the locking screw and turn the flow adjustment handle clockwise to increase, and anti-clockwise to decrease.
Open condition is indicated in digital-scale in built-in revolution indicator.
After flow adjustment, tighten the locking screw.

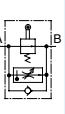

■ Min. Required Pressure Difference

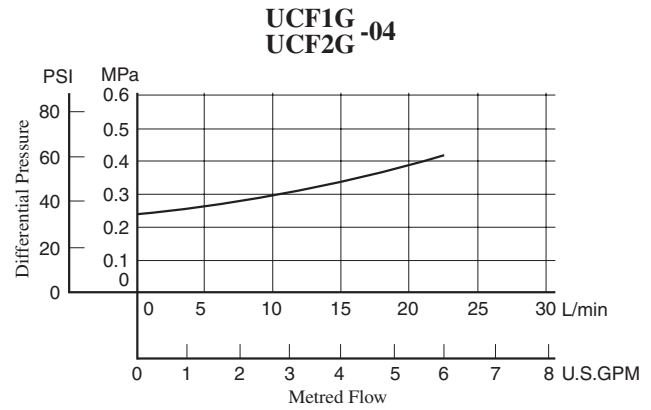
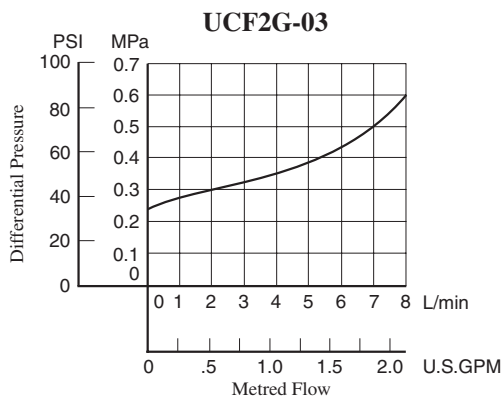
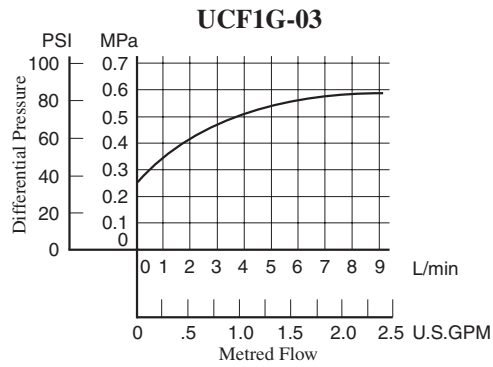
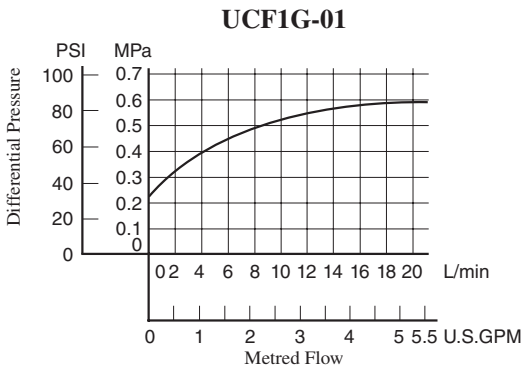

UCF1G-01-***-11/1190

DIMENSIONS IN MILLIMETRES (INCHES)

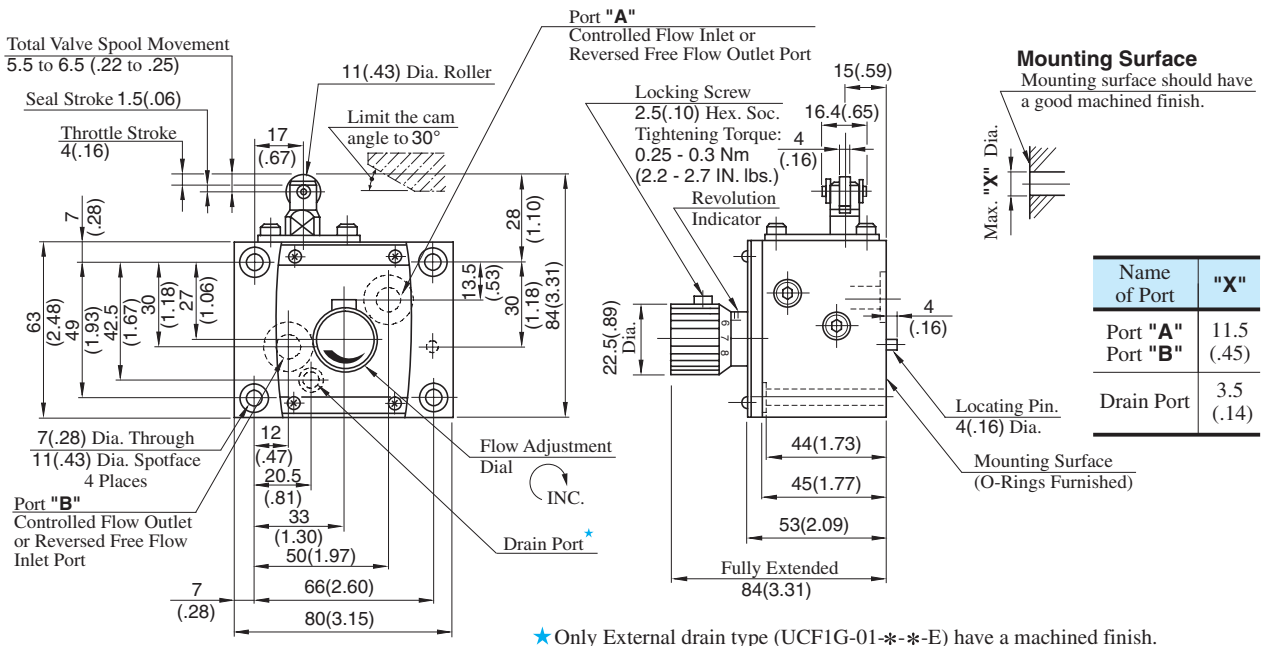

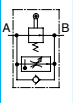

UCF1G-03-*-10/1090

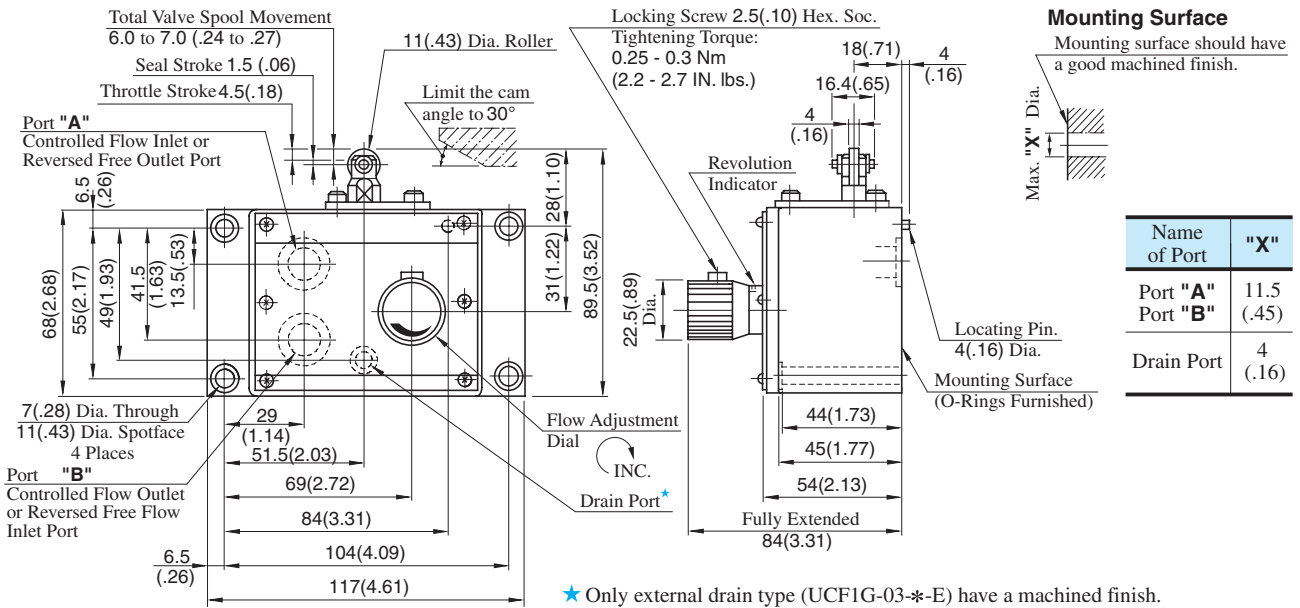

DIMENSIONS IN MILLIMETRES (INCHES)

UCF2G-03-*-10/1090

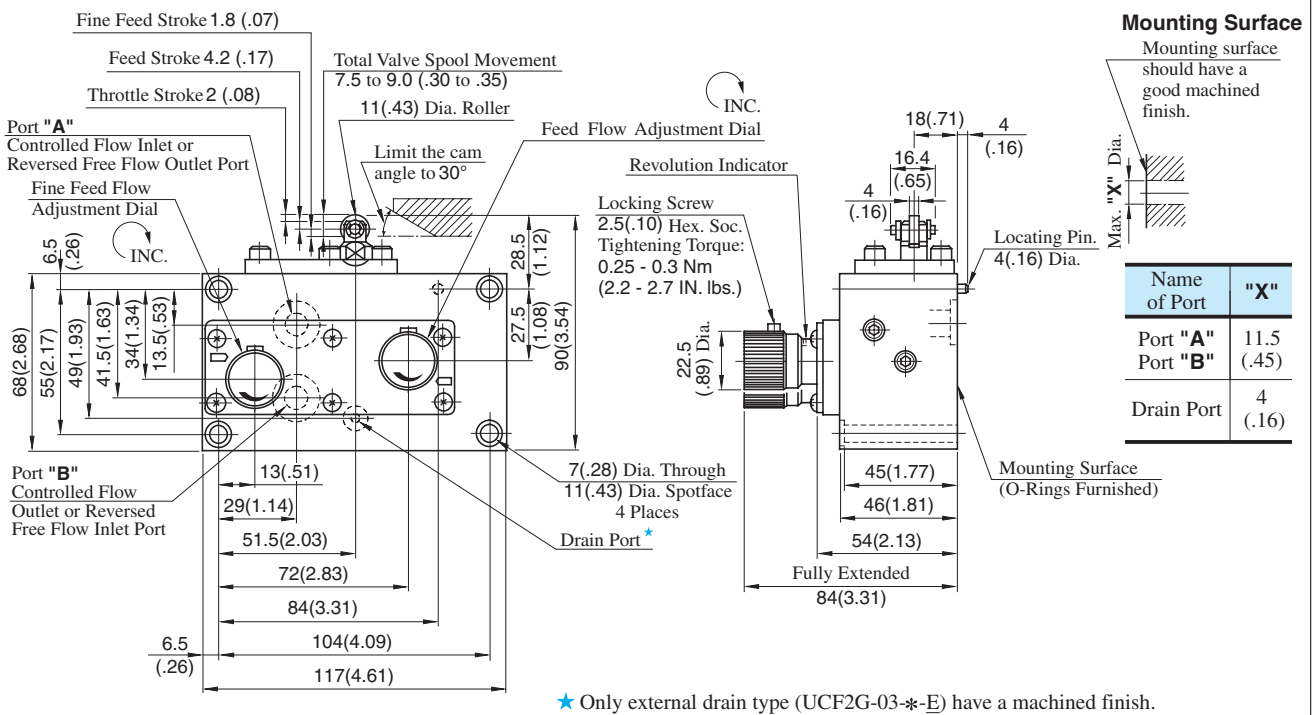

UCF1G-04-30-30/3090

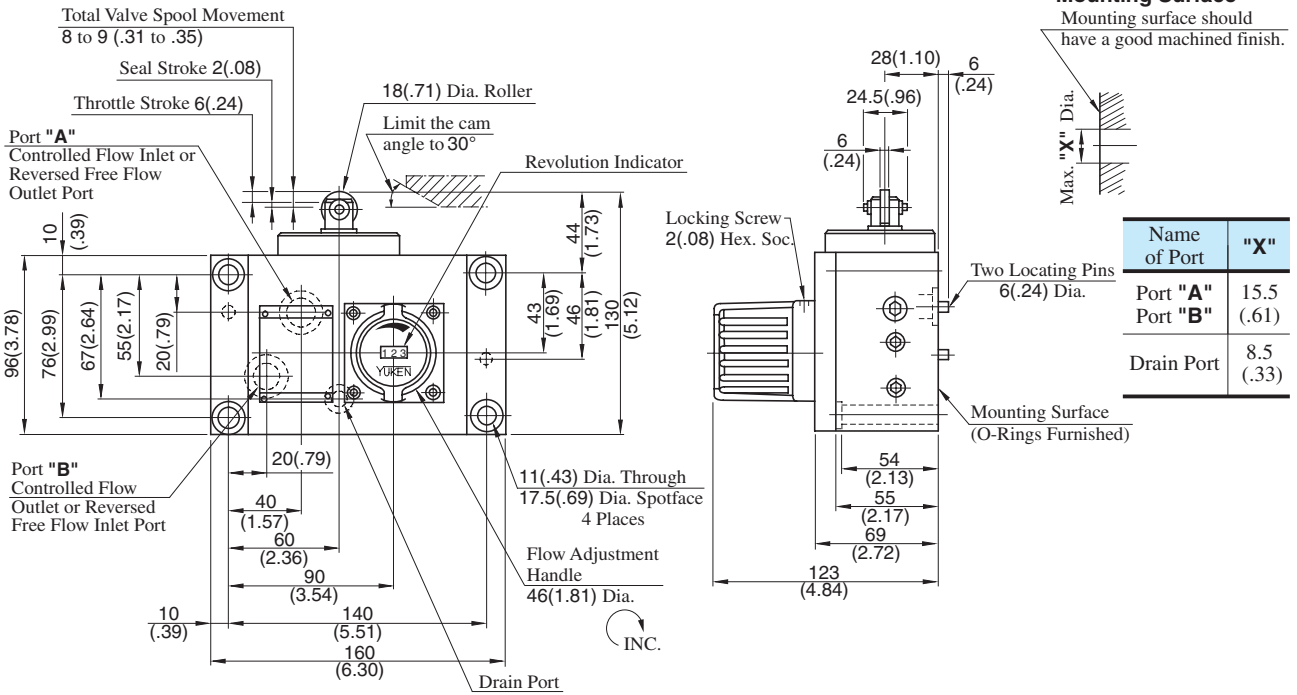

DIMENSIONS IN MILLIMETRES (INCHES)

UCF2G-04-30-30/3090

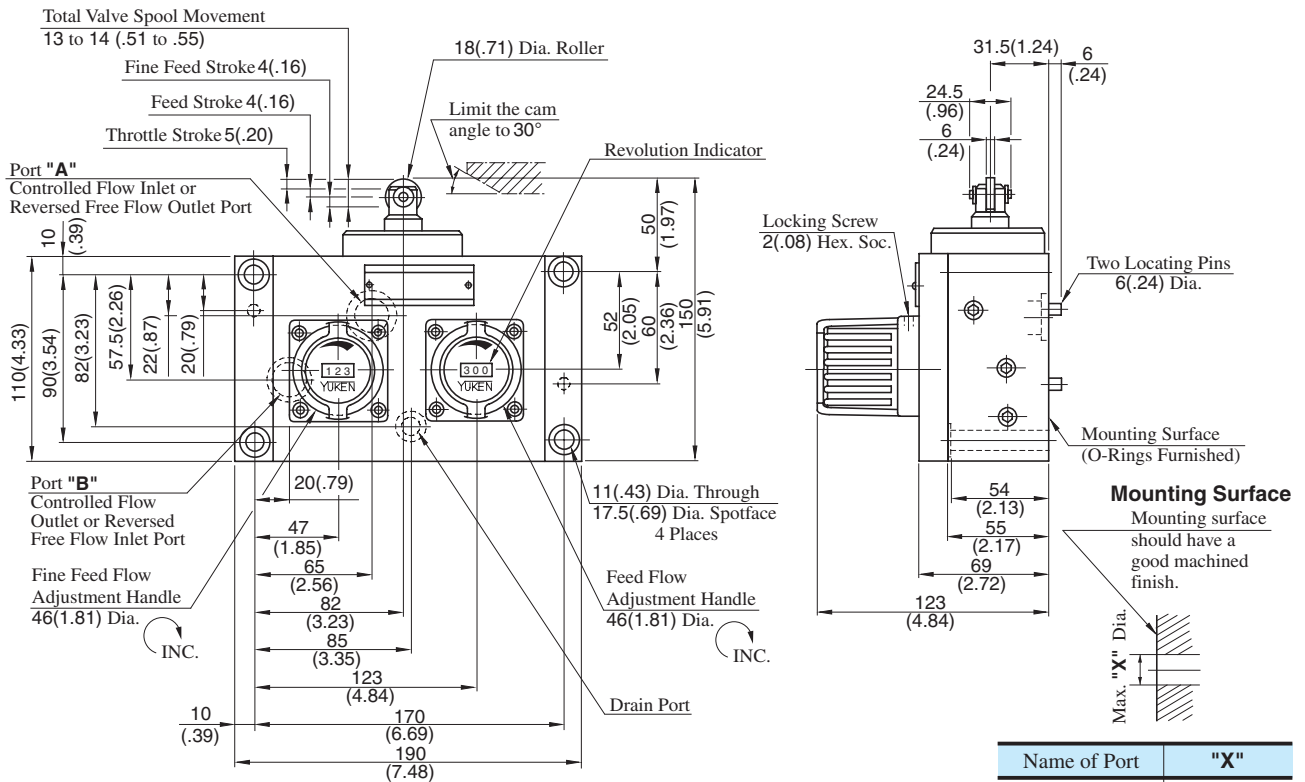

List of Seals

UCF1G-01-*-**-11/1190

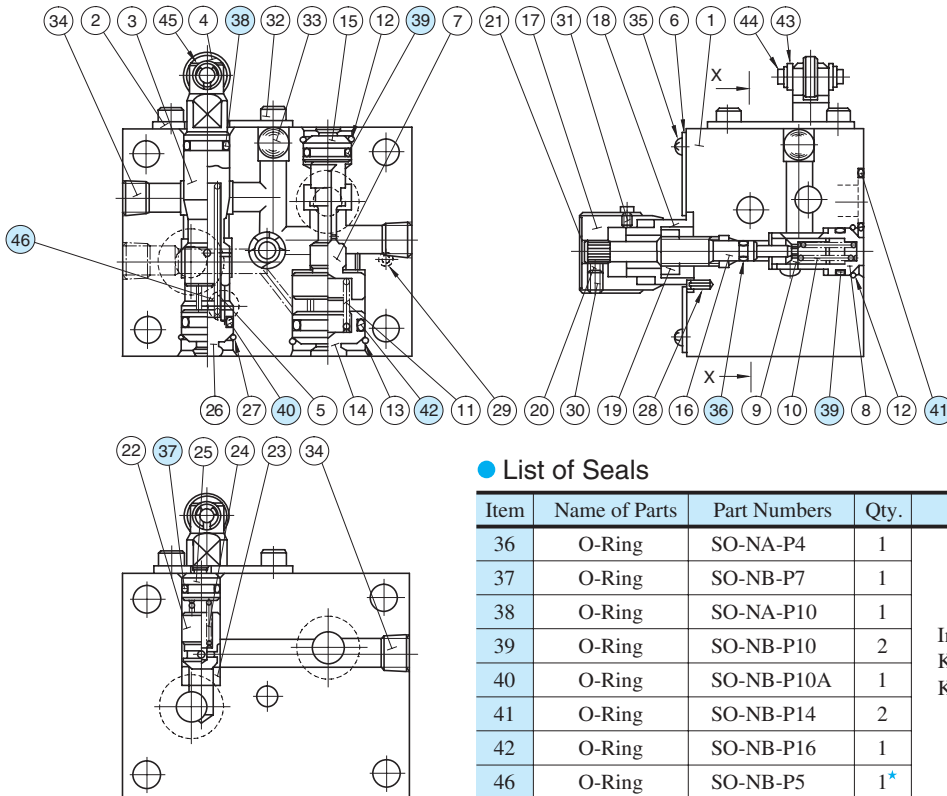

List of Seals

★ Used only for external drain types (UCF1G-01-*-**-E-11*).

UCF1G-03-*-**-10/1090

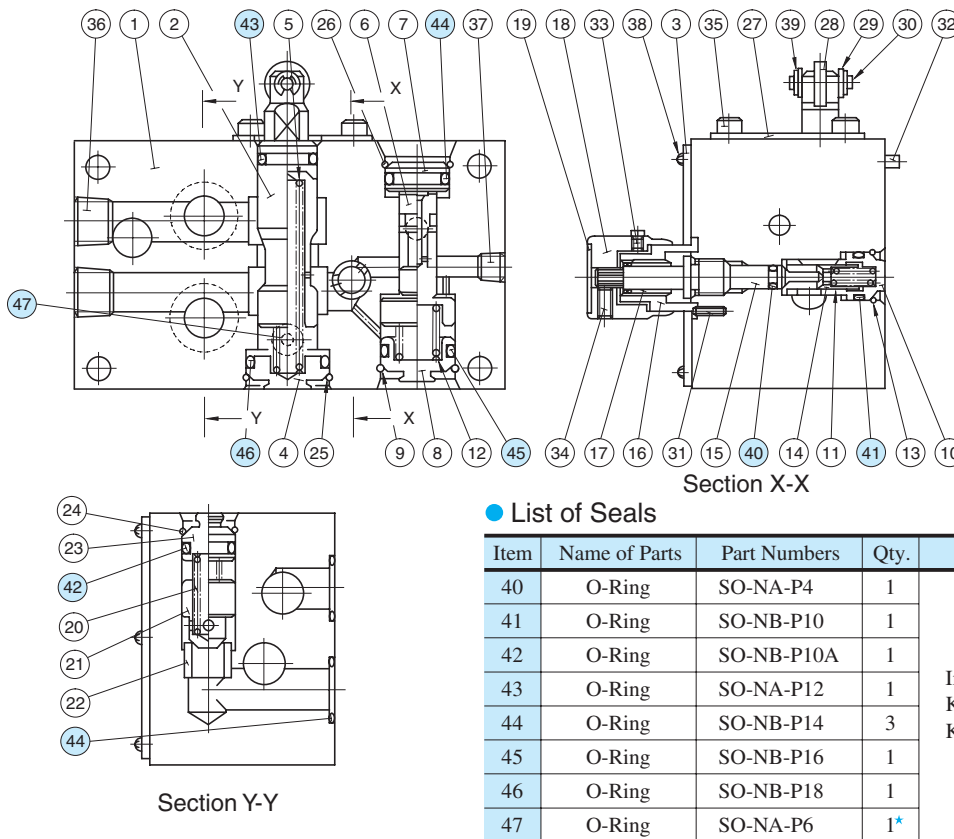

List of Seals

★ Used only for external drain types (UCF1G-03-*-**-E-10*).

UCF2G-03-*-10/1090

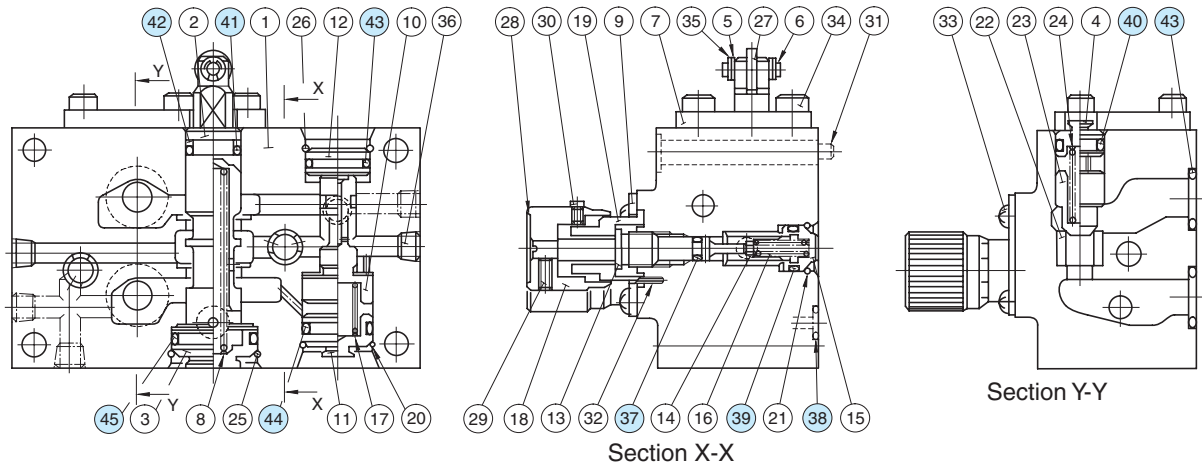

● List of Seals

Item	Name of Parts	Part Numbers	Qty.
37	O-Ring	SO-NA-P4	2
38	O-Ring	SO-NB-P6	1 ^{*1}
39	O-Ring	SO-NB-P10	2
40	O-Ring	SO-NB-P10A	1
41	O-Ring	SO-NA-P12	1
42	Back Up Ring	SO-BB-P12	1 ^{*2}
43	O-Ring	SO-NB-P14	3
44	O-Ring	SO-NB-P16	1
45	O-Ring	SO-NB-P21	1

● List of Seal Kits

Valve Model Numbers	Seal Kit Numbers
UCF2G-03-*-10*	KS-UCF2G-03-10
UCF2G-03-*-E-10*	KS-UCF2G-03-E-10

- ★ 1. Used only for external drain types (UCF2G-03-*-E-10*).
- ★ 2. Used only for internal drain types (UCF2G-03-*-10*).

Note: When ordering the seals, please specify the seal kit number from the table above.

UCF1G-04-30-30/3090
UCF2G-04-30-30/3090

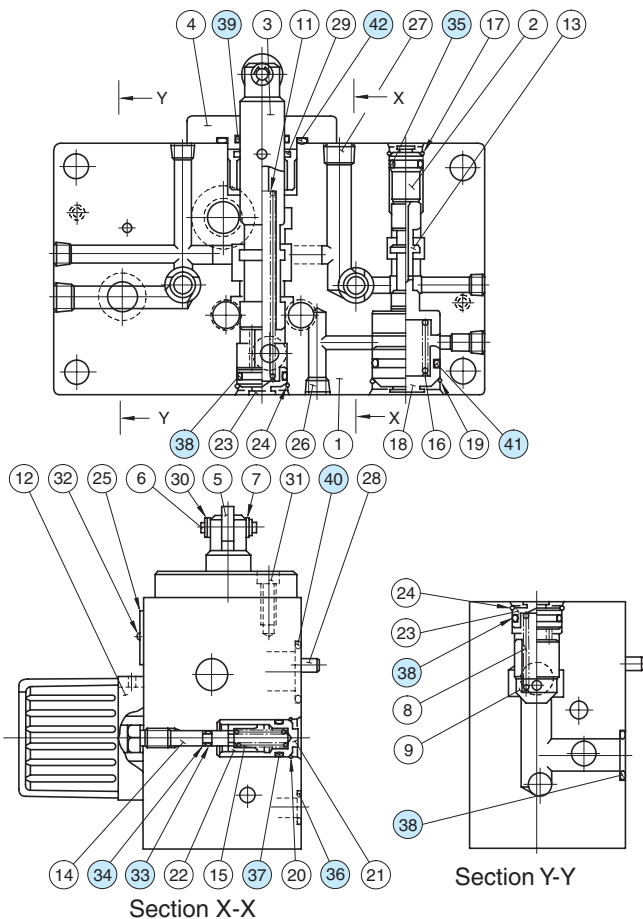

● List of Seals

Item	Name of Parts	Part Numbers	Quantity	
			UCF1G	UCF2G
33	O-Ring	SO-NA-P4	1	2
34	Back Up Ring	SO-BB-P4	1	2
35	O-Ring	SO-NB-P14	1	—
		SO-NB-P10A	—	1
36	O-Ring	SO-NB-P11	1	1
37	O-Ring	SO-NB-P12	1	2
38	O-Ring	SO-NB-P18	3	3
39	O-Ring	SO-NA-P20	1	1
40	O-Ring	SO-NB-P18	1	—
		SO-NB-P22A	—	1
41	O-Ring	SO-NB-G25	1	1
42	O-Ring	SO-NB-P34	1	1

Note: When ordering the seals, please specify the seal kit number from the table below.

● List of Seal Kits

Valve Model Numbers	Seal Kit Numbers
UCF1G-04	KS-UCF1G-04-30
UCF2G-04	KS-UCF2G-04-30