

# Internal gear pump PGF Series 2X and 3X

**RE 10213**

Edition: 05.2015

Replaces: 04.2014



- ▶ Fixed displacement
- ▶ Frame sizes 1, 2 and 3
- ▶ Sizes 1.7 to 40
- ▶ Maximum pressure 250 bar
- ▶ Displacement 1.7 to 40 cm<sup>3</sup>

**Features**

- ▶ Low operating noise
- ▶ Low flow pulsation
- ▶ High efficiency even at low viscosity due to sealing gap compensation
- ▶ Long service life due to slide bearings and sealing gap compensation
- ▶ Suitable for a wide viscosity and speed range
- ▶ Excellent suction characteristics
- ▶ All frame sizes and sizes can be combined with each other
- ▶ Can be combined with PGH internal gear pumps, PV7 vane pumps and axial piston pumps
- ▶ Valve technology can be integrated in the cover on request
- ▶ Use:
  - For drives in the medium-output and medium-pressure range in industrial applications, such as machine tools.
  - At high operating pressure for endurant drives in mobile applications, such as lifting devices, fans and spreaders.

**Contents**

Ordering code	2
Functional description	4
Technical data	5
Characteristic curves	7
Dimensions frame size 1	9
Dimensions frame size 2	12
Dimensions frame size 3	17
Multiple pump units	22
General project planning notes	23
Hydraulic project planning	23
Mechanical project planning	25
Maintenance schedule and operational safety	27
Accessories	27

## Ordering code

01	02	03	04	05	06	07	08	09	10	11
<b>PG</b>	<b>F</b>		-	/				<b>V</b>		*

### Type

01	Internal gear pump, fixed displacement, gap compensated	<b>PG</b>
----	---	-----------

### Series

02	Medium-pressure pump, maximum pressure 250 bar	<b>F</b>
----	--	----------

### Frame size (BG)

03	BG1	<b>1</b>
	BG2	<b>2</b>
	BG3	<b>3</b>

### Series

		BG1	BG2	BG3	
04	Series 20 to 29 (20 to 29: unchanged installation and port dimensions)	●	●	-	<b>2X</b>
	Series 30 to 39 (30 to 39: unchanged installation and port dimensions)	-	-	●	<b>3X</b>

### Size

		NG	
05	BG1	1.7	<b>1,7</b>
		2.2	<b>2,2</b>
		2.8	<b>2,8</b>
		3.2	<b>3,2</b>
		4.1	<b>4,1</b>
		5.0	<b>5,0</b>
	BG2	6.3	<b>006</b>
		8.0	<b>008</b>
		11.0	<b>011</b>
		13.0	<b>013</b>
		16.0	<b>016</b>
		19.0	<b>019</b>
	BG3	22.0	<b>022</b>
		20.0	<b>020</b>
		25.0	<b>025</b>
32.0		<b>032</b>	
	40.0	<b>040</b>	

### Direction of rotation

06	Viewed on drive shaft	clockwise	<b>R</b>
		counter-clockwise	<b>L</b>

### Drive shaft

07	Parallel keyed shaft, ISO 3019-2	<b>A</b>
	Parallel keyed shaft, ISO 3019-2 with through drive	<b>E</b>
	Splined shaft to SAE J744 with involute tooth system according to ANSI B92.1a	<b>J</b>
	Two surfaces for open-jaw coupling	<b>N</b>
	Two surfaces for open-jaw coupling with through drive	<b>L</b>
	Tapered shaft 1:5 with through drive <sup>1)</sup>	<b>O</b>

### Line connections

08	Line thread according to ISO 228-1	<b>01</b>
	Suction and pressure port according to SAE J518	<b>07</b>
	Square flange port, metric fastening thread	<b>20</b>

1) With adapter for LKW auxiliary drive

01	02	03		04		05	06	07	08	09	10	11
<b>PG</b>	<b>F</b>		-		/					<b>V</b>		*

**Seal material**

09	FKM (fluor-caoutchouc)	<b>V</b>
----	------------------------	----------

**Mounting flange**

10	Special flange according to ISO 7653-1985 (for truck auxiliary drive)	<b>K4</b>
	4-hole mounting flange according to ISO 3019-2 and VDMA 24560 Part 1	<b>E4</b>
	2-hole mounting flange according to ISO 3019-1	<b>U2</b>
	2-hole mounting flange, spigot diameter 32 mm (BG1), spigot diameter 52 mm (BG2 and BG3)	<b>M</b>
	2-hole mounting flange, spigot diameter 50 mm	<b>P</b>
	2-hole mounting flange, spigot diameter 45.24 mm	<b>P1</b>
	2-hole mounting flange, spigot diameter 63 mm	<b>P2</b>

**Optional**

11	Feeder valve	<b>N</b>
	Cover for mounting the next frame size down	<b>K</b>

12	Further parameters in clear text	*
----	----------------------------------	---

Type	Material number
PGF2-2X/011RE01VE4	R900932271

Not all of the variants according to the ordering code are possible! Please select the desired pump with the help of the selection table on pages 9 to 20 or after consultation with Bosch Rexroth!

Special options are available on request, e.g., integrated pressure-relief valves.

## Functional description

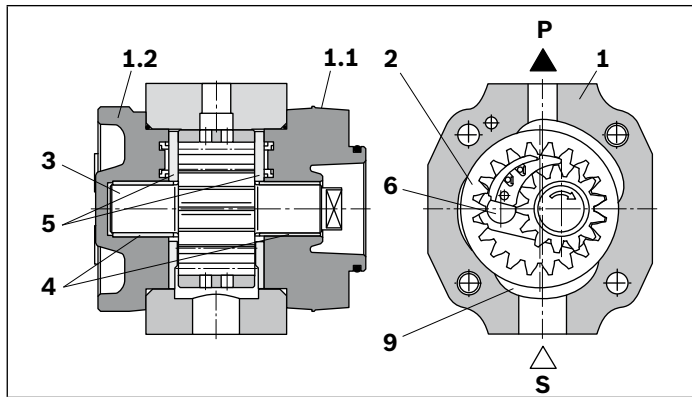

### Design

PGF hydraulic pumps are leak-gap-compensated internal gear pumps with a fixed displacement. They consist basically of: housing (1), bearing cover (1.1), cover (1.2), ring gear (2), pinion shaft (3), slide bearings (4), axial discs (5) and stop pin (6) as well as the segment assembly (7) which is composed of a segment (7.1), segment carrier (7.2) and the sealing rolls (7.3).

### Suction and displacement process

The hydrodynamically supported pinion shaft (3) drives the internally toothed ring gear (2) in the direction of rotation shown.

During rotation, the volume is increased in the suction area over an angle of approx. 180°. A negative pressure is generated and fluid flows into the chambers.

The sickle-shaped segment assembly (7) separates the suction chamber from the pressure chamber. Within the pressure chamber, the teeth of the pinion shaft (3) mesh with the tooth spaces of the ring gear (2). The fluid is then displaced through the pressure channel (P).

### Axial compensation

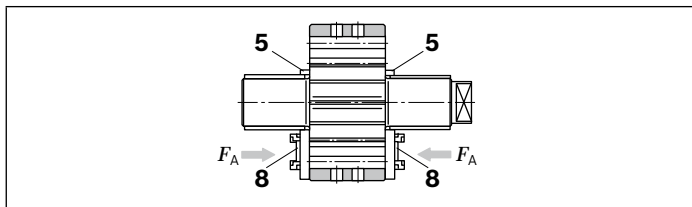

The axial compensation force  $F_A$  acts in the area of the pressure chamber and is generated by the pressure zone (8) in the axial discs (5). The axial, longitudinal gaps between rotating and fixed parts are therefore extremely small and ensure optimum axial sealing of the pressure chamber.

### Radial compensation

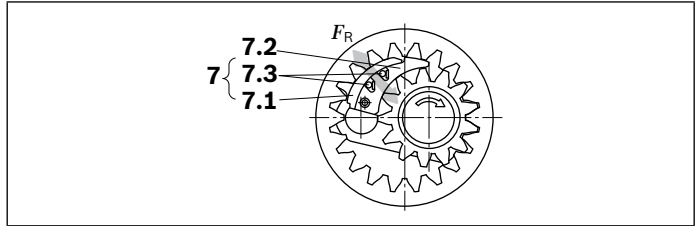

The radial compensation force  $F_R$  acts on the segment (7.1) and segment carrier (7.2).

The area ratios and the position of the sealing rolls (7.3) between the segment and segment carrier are designed to provide virtually gap-free sealing between the ring gear (2), the segment assembly (7) and the pinion shaft (3).

Spring elements under the sealing rolls (7.3) ensure adequate contact pressure, even at very low pressures.

### Hydrodynamic and hydrostatic bearing

The forces acting on the pinion shaft (3) are absorbed by hydrodynamically lubricated radial slide bearings (4) while those acting on the ring gear (2) are absorbed by the hydrostatic bearing (9).

### Splines

Involute splining was selected for the gear. Their long length of contact results in a low flow and pressure pulsation; these low pulsation rates contribute greatly to the low-noise operation.

### Used materials

Housing (1), bearing cover (1.1), cover (1.2) and axial discs (5): Aluminum alloy

Ring gear (2), pinion shaft (3) and stop pin (6): Steel

Slide bearing (4): Copper-tin with steel back

Segment (7.1) and segment carrier (7.2): Brass alloy

Sealing rolls (7.3): Plastic

### ▼ Symbol

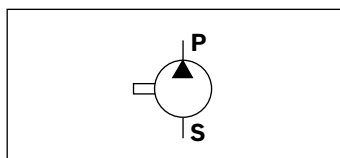

**Technical data**

Frame size		BS	1	1	1	1	1	1
Size		NG	1.7	2.2	2.8	3.2	4.1	5.0
Displacement, geometric	$V_g$	cm <sup>3</sup>	1.7	2.2	2.8	3.2	4.1	5.0
Input speed	$n_{min}$	rpm	600	600	600	600	600	600
	$n_{max}$	rpm	4500	3600	4000	3600	3600	3600
Operating pressure, absolute								
Inlet	$p$	bar	0.6 to 3	0.6 to 3	0.6 to 3	0.6 to 3	0.6 to 3	0.6 to 3
Outlet	continuous	$p_N$	bar	180	210	210	210	180
	intermittend <sup>1)</sup>	$p_{max}$	bar	210	250	250	250	210
Flow (at $n = 1450$ rpm, $p = 10$ bar, $v = 30$ mm <sup>2</sup> /s)	$q_v$	l/min	2.4	3.2	4.1	4.6	6.0	7.2
Power consumption								
Minimum required Drive power (at $p \approx 1$ bar)	$P_{input}$	kW	0.75	0.75	0.75	0.75	0.75	0.75
Moment of inertia (around drive axis)	$J$	kgm <sup>2</sup>	0.000012	0.000013	0.000015	0.000017	0.000021	0.000026
Weight <sup>2)</sup>	$m$	kg	0.8	0.9	1.0	1.0	1.1	1.3
Shaft loading	Radial and axial forces (e.g., belt pulley) only after consultation							
Type of mounting	Flange mounting							

Frame size		BS	2	2	2	2	2	2
Size		NG	6.3	8	11	13	16	22
Displacement, geometric	$V_g$	cm <sup>3</sup>	6.5	8.2	11	13.3	16	22
Input speed	$n_{min}$	rpm	600	600	600	600	600	600
	$n_{max}$	rpm	3600	3600	3600	3600	3600	3000
Operating pressure, absolute								
Inlet	$p$	bar	0.6 to 3	0.6 to 3	0.6 to 3	0.6 to 3	0.6 to 3	0.6 to 3
Outlet	continuous	$p_N$	bar	210	210	210	210	180
	intermittend <sup>1)</sup>	$p_{max}$	bar	250	250	250	250	210
Flow (at $n = 1450$ rpm, $p = 10$ bar, $v = 30$ mm <sup>2</sup> /s)	$q_v$	l/min	9.4	11.9	16	19.3	23.3	31.9
Power consumption								
Minimum required Drive power (at $p \approx 1$ bar)	$P_{input}$	kW	0.75	0.75	0.75	0.75	0.75	1.1
Moment of inertia (around drive axis)	$J$	kgm <sup>2</sup>	0.000074	0.000090	0.00012	0.00014	0.00016	0.00019
Weight <sup>2)</sup>	$m$	kg	2.1	2.2	2.4	2.6	2.7	3.1
Shaft loading	Radial and axial forces (e.g., belt pulley) only after consultation							
Type of mounting	Flange mounting							

1) Maximum 6 s, up to 15% of duty cycle, maximum  $2 \times 10^6$  load cycles

2) For pumps with 2-hole mounting as flanged version  
 ► Frame size 2 approx. 0.9 kg heavier  
 ► Frame size 3 approx. 1.0 kg heavier

Frame size		BS	3	3	3	3	
Size		NG	20	25	32	40	
Displacement, geometric	$V_g$	cm <sup>3</sup>	20.6	25.4	32.5	40.5	
Input speed	$n_{min}$	rpm	500	500	500	500	
	$n_{max}$	rpm	3600	3200	3000	2500	
Operating pressure, absolute							
Inlet	$p$	bar	0.6 to 3	0.6 to 3	0.6 to 3	0.6 to 3	
Outlet	continuous	$p_N$	bar	210	210	210	180
	intermittend <sup>1)</sup>	$p_{max}$	bar	250	250	250	210
Flow (at $n = 1450$ rpm, $p = 10$ bar, $v = 30$ mm <sup>2</sup> /s)	$q_v$	l/min	29.9	36.8	47.1	58.7	
Power consumption							
Minimum required Drive power (at $p \approx 1$ bar)	$P_{input}$	kW	1.1	1.5	1.5	1.5	
Moment of inertia (around drive axis)	$J$	kgm <sup>2</sup>	0.00029	0.00035	0.00043	0.00053	
Weight <sup>2)</sup>	$m$	kg	3.3	4.1	4.5	4.9	
Shaft loading	Radial and axial forces (e.g., belt pulley) only after consultation						
Type of mounting	Flange mounting						
<b>Hydraulic fluid</b>							
Permissible hydraulic fluid <sup>3)</sup>	HL mineral oil according to DIN 51524 Part 1/HLP, mineral oil according to DIN 51524 Part 2 HEES fluids according to DIN ISO 15380 HEPR fluids according to DIN ISO 15380						
Operating temperature range	-20 to +100 °C						
Ambient temperature range	-20 to +60 °C						
Viscosity range	10 to 300 mm <sup>2</sup> /s <sup>2</sup>						
Permissible starting viscosity	2000 mm <sup>2</sup> /s <sup>2</sup>						
Maximum permissible degree of contamination of the hydraulic fluid	Class 20/18/15 <sup>4)</sup>						
Cleanliness level according to ISO 4406 (c)							
Permissible radial loading of the pinion shaft	On request						

**Note**

- ▶ Please contact us if the unit is to be used outside the specified values.
- ▶ Observe our specifications according to data sheet 90220.

1) Maximum 6 s, up to 15% of duty cycle, maximum  $2 \times 10^6$  load cycles

2) For pumps with 2-hole mounting as flanged version  
 ▶ Frame size 2 approx. 0.9 kg heavier  
 ▶ Frame size 3 approx. 1.0 kg heavier

3) Other hydraulic fluids on request

4) Cleanliness levels specified for the components must be maintained in the hydraulic systems. Effective filtration prevents malfunctions and simultaneously extends the service life of the components.

## Characteristic curves

### Frame size 1

#### ▼ Flow

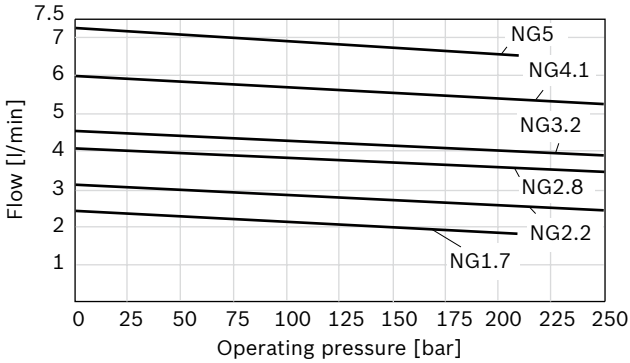

#### ▼ Efficiency

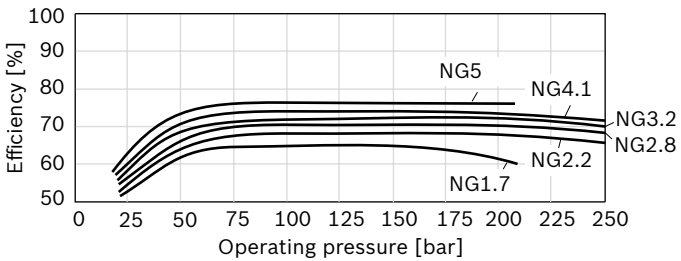

#### ▼ Drive power

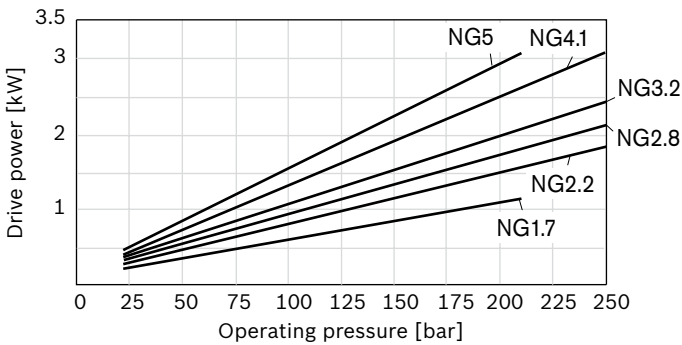

#### ▼ Sound pressure level

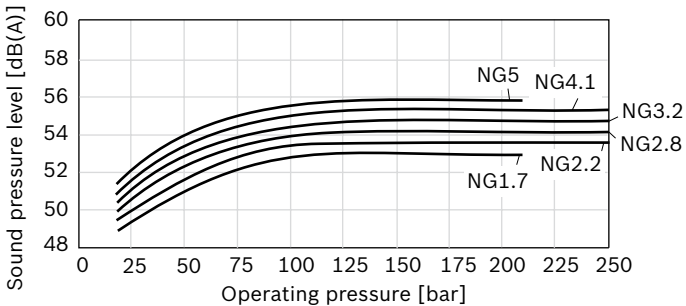

### Frame size 2

#### ▼ Flow

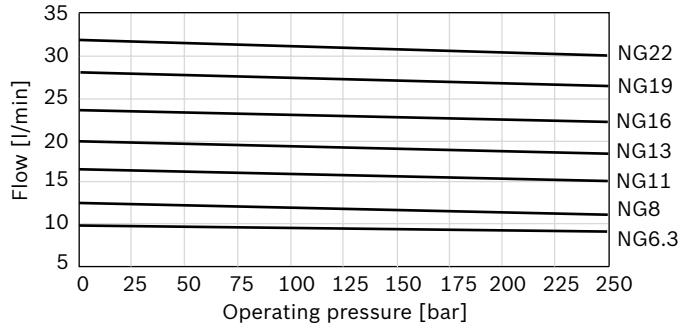

#### ▼ Efficiency

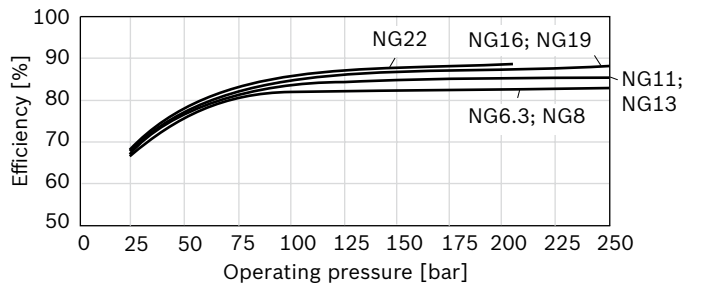

#### ▼ Drive power

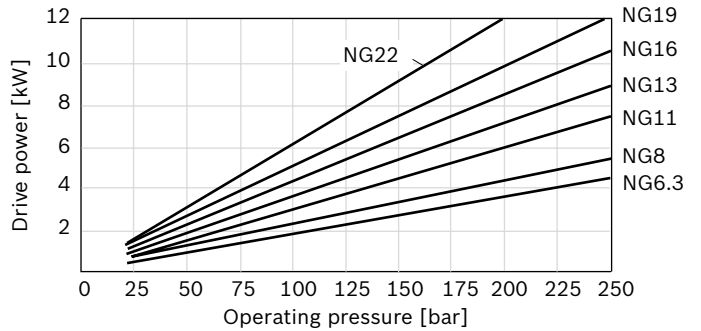

#### ▼ Sound pressure level

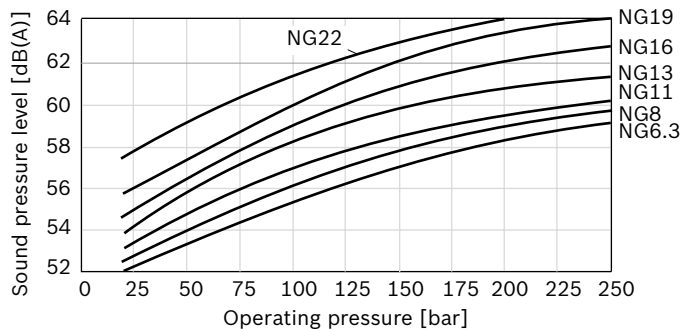

### Note

- ▶ Characteristics measured at  $n = 1450$  rpm;  $v = 46$  mm<sup>2</sup>/s;  $\theta = 40$  °C
- ▶ Sound pressure level measured in acoustic room according to DIN 45635, Sheet 26; Distance: microphone – pump = 1 m

**Frame size 3**

▼ **Flow**

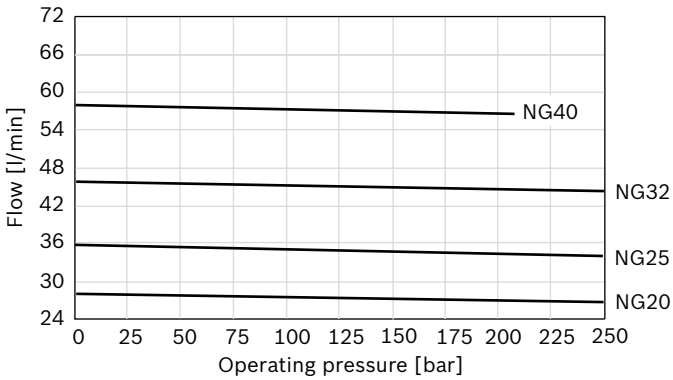

▼ **Efficiency**

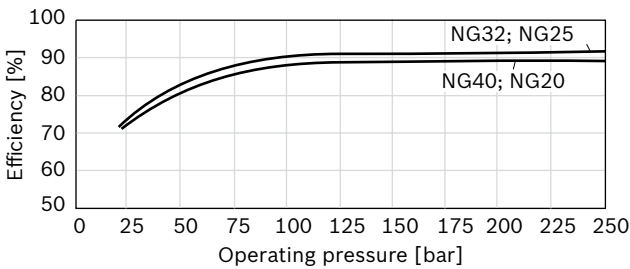

▼ **Drive power**

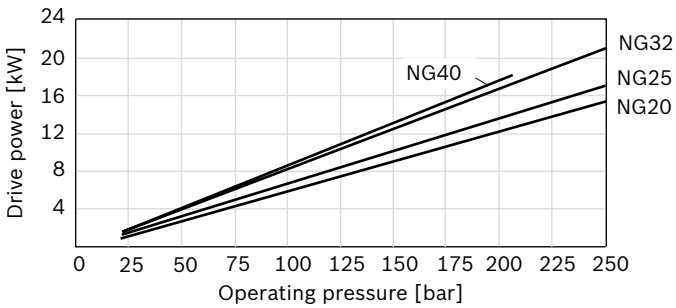

▼ **Sound pressure level**

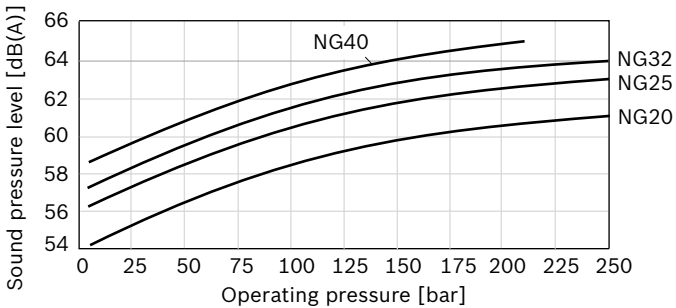

**Note**

- ▶ Characteristics measured at  $n = 1450$  rpm;  $v = 46$  mm<sup>2</sup>/s;  $\theta = 40$  °C
- ▶ Sound pressure level measured in acoustic room according to DIN 45635, Sheet 26; Distance: microphone – pump = 1 m



### Dimensions frame size 1

#### Parallel keyed shaft, DIN 6885, without through drive

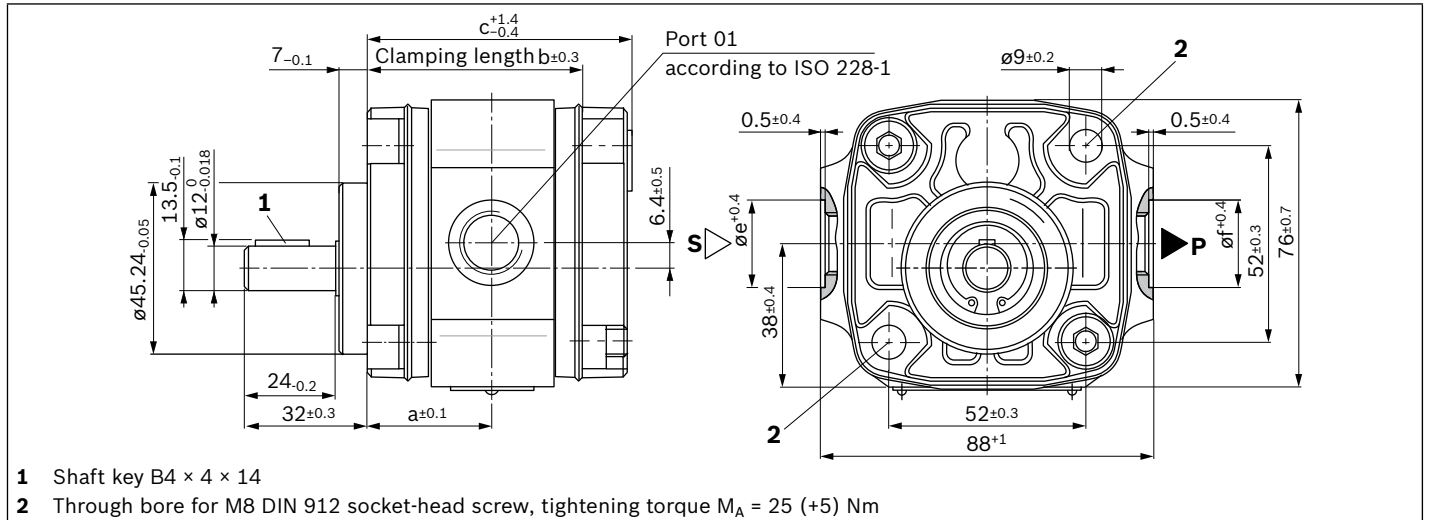

Type	Material numbers	a	b	c	øe	øf	Suction port S according to ISO 228-1	Pressure port P according to ISO 228-1
PGF1-2X/ <b>1,7</b> R <b>A</b> 01VP1 R900932132		29.6	49.1	61.1	23	23	G1/4; 14 deep	G1/4; 12.5 deep
<b>2,2</b> R <b>A</b> 01VP1 R900932133		29.6	49.1	61.1	23	23	G1/4; 14 deep	G1/4; 12.5 deep
<b>2,8</b> R <b>A</b> 01VP1 R900932134		30.7	51.4	63.4	26	23	G3/8; 14 deep	G1/4; 12.5 deep
<b>3,2</b> R <b>A</b> 01VP1 R900932135		31.5	53.0	65	26	23	G3/8; 14 deep	G1/4; 12.5 deep
<b>4,1</b> R <b>A</b> 01VP1 R900932136		33.4	56.7	68.7	26	26	G3/8; 14 deep	G3/8; 12.5 deep
<b>5,0</b> R <b>A</b> 01VP1 R900932137		35.2	60.4	72.4	27	26	G1/2; 14 deep	G3/8; 12.5 deep

#### Parallel keyed shaft, DIN 6885, with through drive

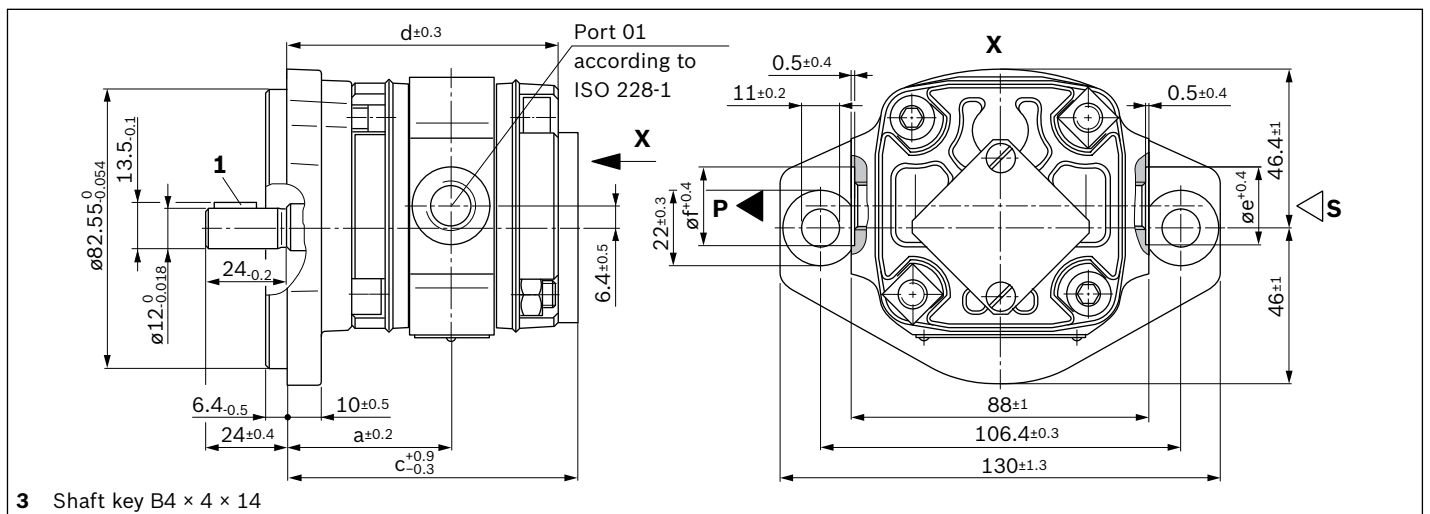

Type	Material numbers	a	c	d	øe	øf	Suction port S according to ISO 228-1	Pressure port P according to ISO 228-1
PGF1-2X/ <b>1,7</b> R <b>E</b> 01VU2 R900086159		48.6	85.7	79.7	23	23	G1/4; 14 deep	G1/4; 12.5 deep
<b>2,2</b> R <b>E</b> 01VU2 R900086160		48.6	85.7	79.7	23	23	G1/4; 14 deep	G1/4; 12.5 deep
<b>2,8</b> R <b>E</b> 01VU2 R900086161		49.7	88.0	82.0	26	23	G3/8; 14 deep	G1/4; 12.5 deep
<b>3,2</b> R <b>E</b> 01VU2 R900086162		50.5	89.6	83.6	26	23	G3/8; 14 deep	G1/4; 12.5 deep
<b>4,1</b> R <b>E</b> 01VU2 R900086163		52.4	93.3	87.3	26	26	G3/8; 14 deep	G3/8; 12.5 deep
<b>5,0</b> R <b>E</b> 01VU2 R900086164		54.2	97.0	91.0	27	26	G1/2; 14 deep	G3/8; 12.5 deep

**Shaft for open-jaw coupling, without through drive, rear pump**

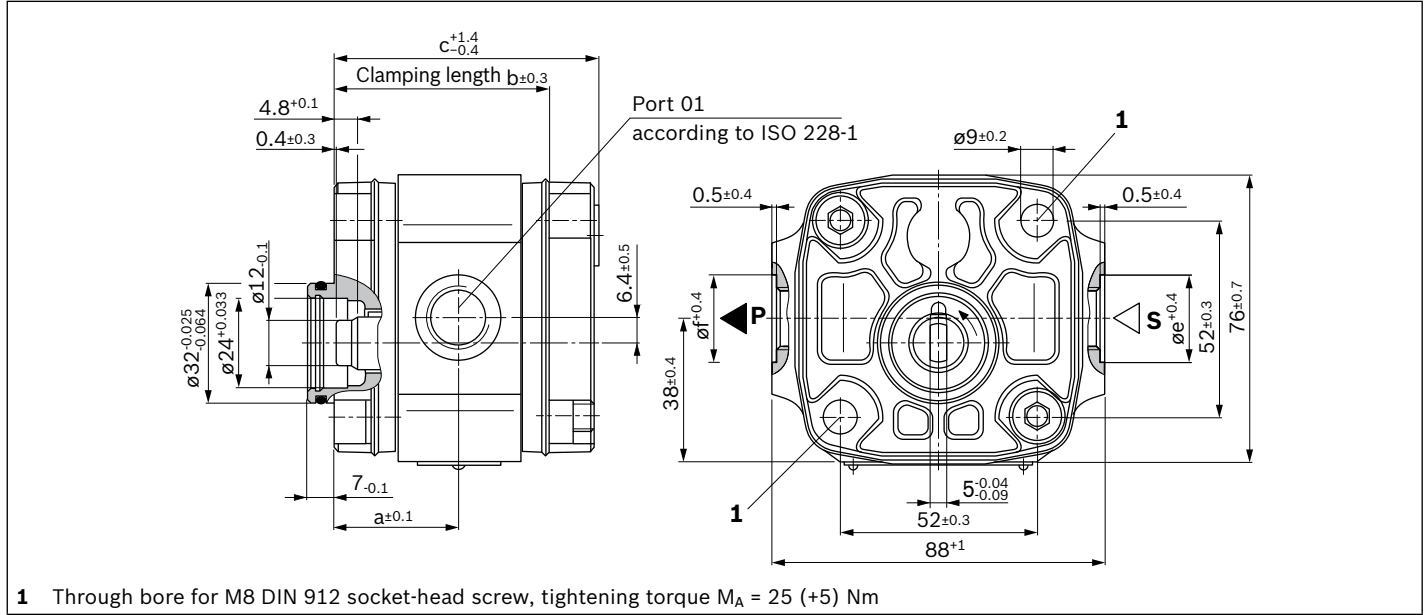

Type	Material numbers	a	b	c	øe	øf	Suction port S according to ISO 228-1	Pressure port P according to ISO 228-1
PGF1-2X/ <b>1,7</b> L N 01VM	R900086147	29.6	49.1	61.1	23	23	G1/4; 14 deep	G1/4; 12.5 deep
<b>2,2</b> L N 01VM	R900086148	29.6	49.1	61.1	23	23	G1/4; 14 deep	G1/4; 12.5 deep
<b>3,2</b> L N 01VM	R900086150	31.5	53.0	65	26	23	G3/8; 14 deep	G1/4; 12.5 deep
<b>4,1</b> L N 01VM	R900932131	33.4	56.7	68.7	26	26	G3/8; 14 deep	G3/8; 12.5 deep

▼ **Driver**

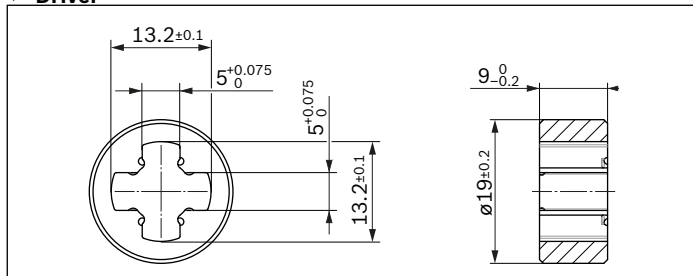

The driver (material number R900984336) is included in the scope of supply.

**Shaft for open-jaw coupling, with through drive, middle or rear pump**

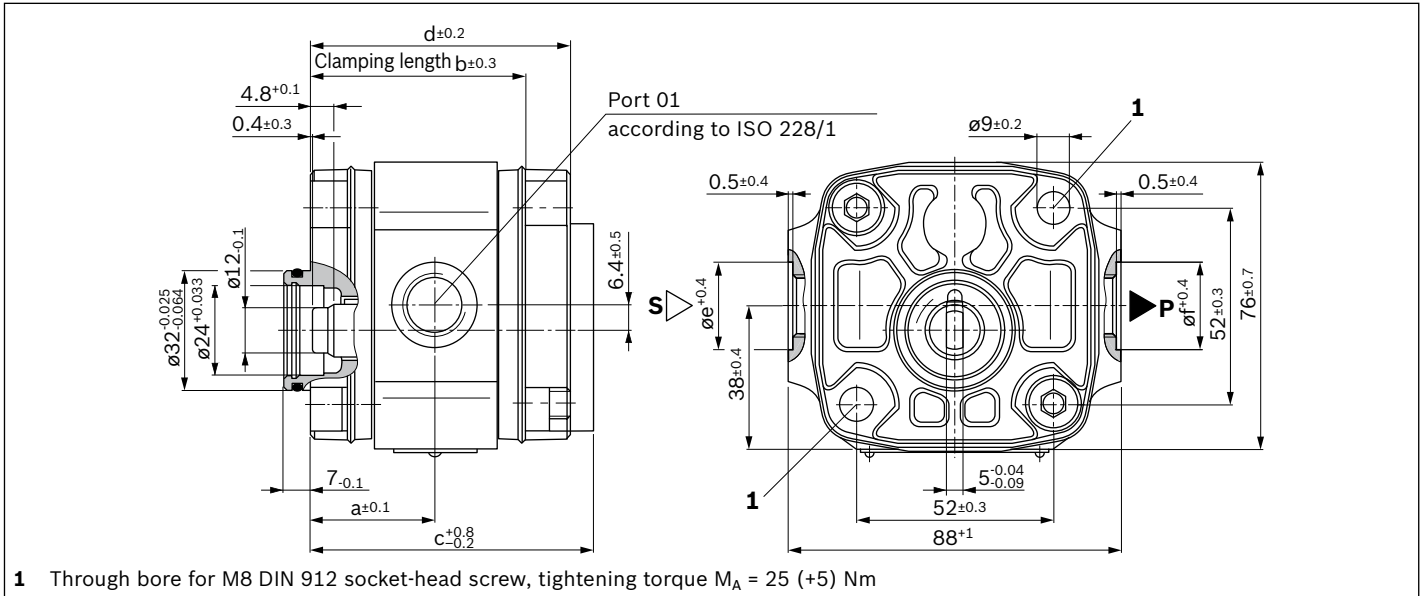

Type			Material numbers	a	b	c	d	øe	øf	Suction port S according to ISO 228-1	Pressure port P according to ISO 228-1	
PGF1-2X/ <b>1,7</b>	R	L	01VM	R900086165	29.6	49.1	66.7	60.7	23	23	G1/4; 14 deep	G1/4; 12.5 deep
		L		R900932093								
<b>2,2</b>	R	L	01VM	R900086166	29.6	49.1	66.7	60.7	23	23	G1/4; 14 deep	G1/4; 12.5 deep
		L		R900932094								
<b>2,8</b>	R	L	01VM	R900932138	30.7	51.4	69.0	63.0	26	23	G3/8; 14 deep	G1/4; 12.5 deep
		L		R900951293								
<b>3,2</b>	R	L	01VM	R900086168	31.5	53.0	70.6	64.6	26	23	G3/8; 14 deep	G1/4; 12.5 deep
		L		R900951294								
<b>4,1</b>	R	L	01VM	R900086169	33.4	56.7	74.3	68.3	26	26	G3/8; 14 deep	G3/8; 12.5 deep
		L		R900088913								
<b>5,0</b>	R	L	01VM	R900086170	35.2	60.4	78.0	72.0	27	26	G1/2; 14 deep	G3/8; 12.5 deep
		L		R900951295								

▼ **Driver**

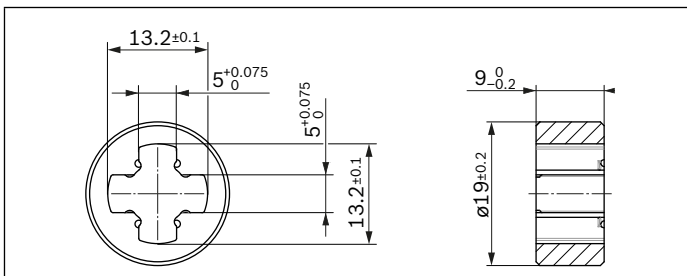

The driver (material number R900984336) is included in the scope of supply.

## Dimensions frame size 2

### Shaft for open-jaw coupling, without through drive, rear pump

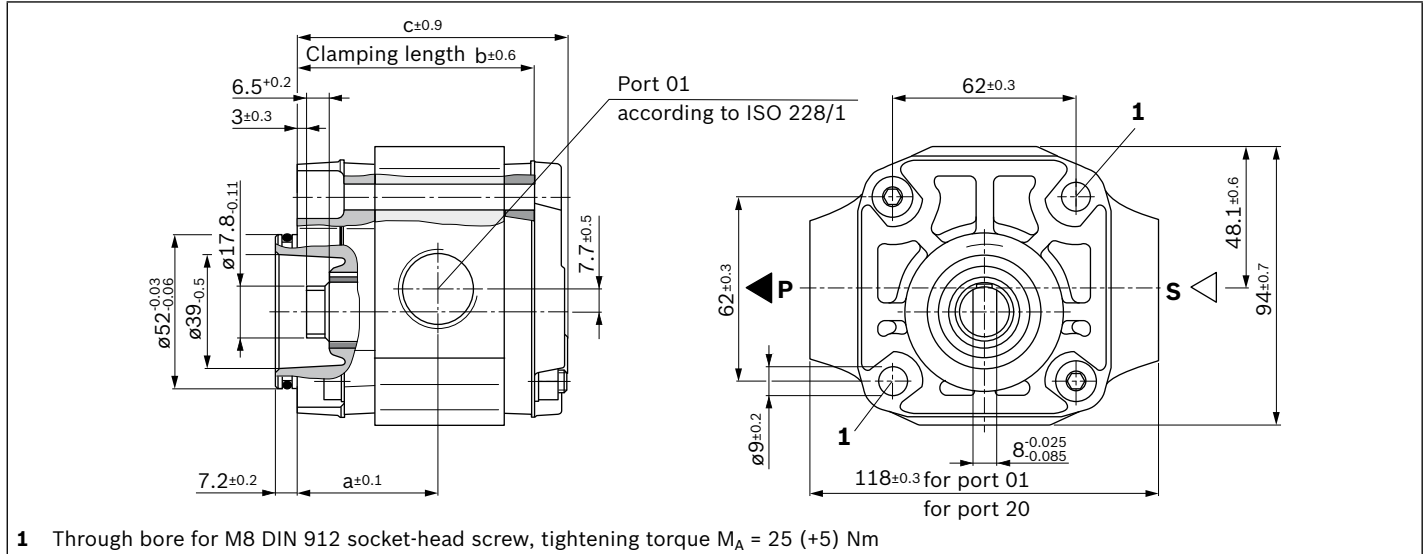

Type	Material numbers	a	b	c	Port standard	Port optional
PGF2-2X/	<b>006 L N</b> 01VM R900563948	46	76	87.2	01	20
	<b>008 L N</b> 01VM R900062364	47.8	79.5	90.7	01	20
	<b>011 L N</b> 01VM R900077364	50.5	85	96.2	01	20
	<b>013 L N</b> 20VM R900034010	53	90	101.2	20	01
	<b>016 L N</b> 20VM R900033354	55.5	95	106.2	20	01
	<b>019 L N</b> 20VM R900932120	58.5	101	112.2	20	01
	<b>022 L N</b> 20VM R900081192	61.5	107	118.2	20	-

#### ▼ Port 01, line thread according to ISO 228-1

NG	Suction port S	Pressure port P
<b>006, 008, 011, 013</b>	G3/4; 16 deep	G1/2; 14 deep
<b>016, 019</b>	G1; 18 deep	G1/2; 14 deep

#### ▼ Driver

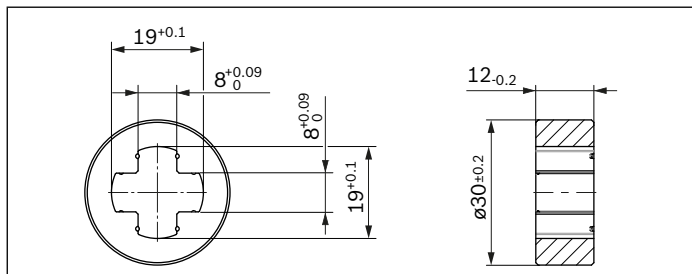

The driver (material number R900981428) is included in the scope of supply.

#### ▼ Port 20, square flange port

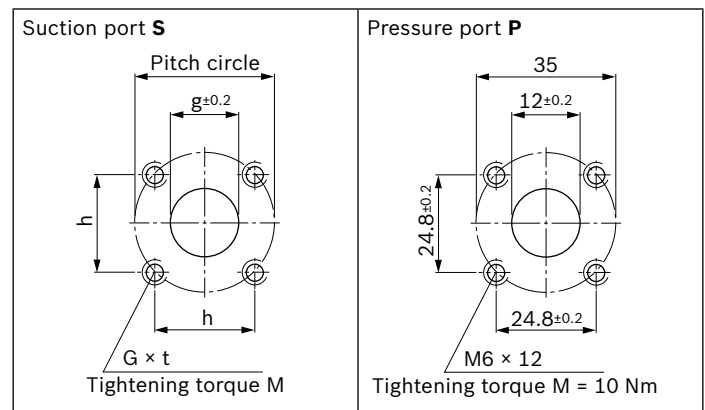

NG	g	h	Pitch circle	G	t	M [Nm]
<b>006, 008, 011, 013, 016</b>	20	28.3±0.2	40	M6	10	10
<b>019, 022</b>	26	38.9±0.3	55	M8	12	25

**Shaft for open-jaw coupling, with through drive, middle or rear pump**

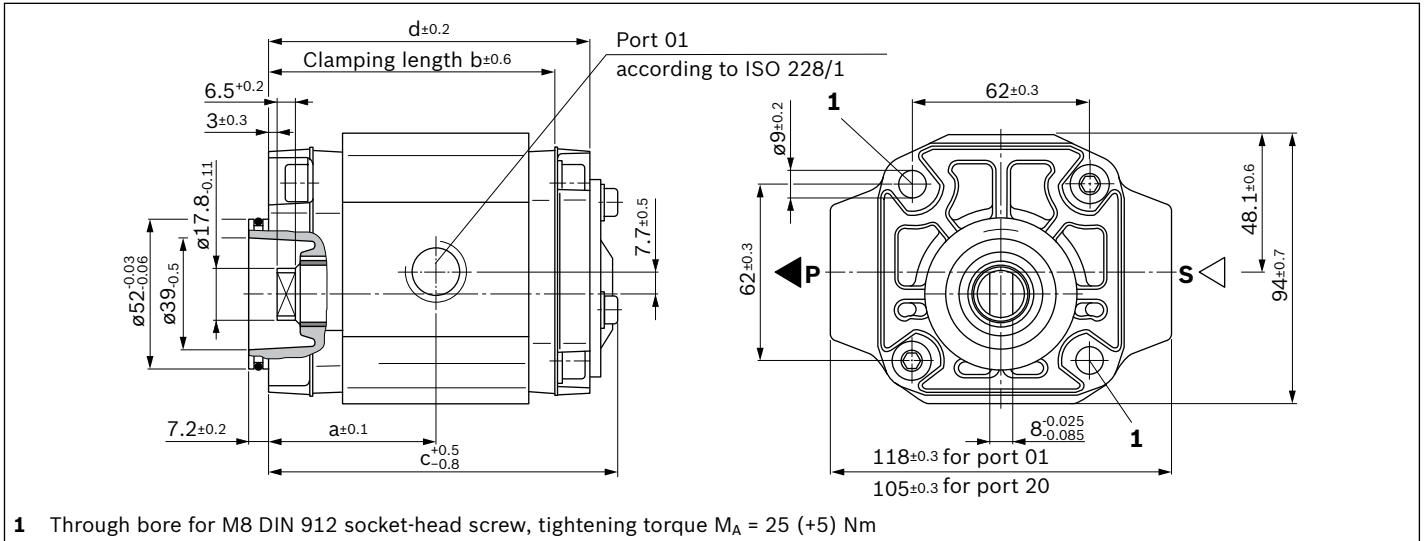

Type			Material numbers	a	b	c	d	Port standard	Port optional
PGF2-2X/ <b>006</b>	R	L	01VM	46	76	98.2	87.1	01	20
		L							
<b>008</b>	R	L	01VM	47.8	79.5	101.7	90.6	01	20
		L							
<b>011</b>	R	L	01VM	50.5	85	107.2	96.1	01	20
		L							
<b>013</b>	R	L	20VM	53	90	112.2	101.1	20	01
		L							
<b>016</b>	R	L	20VM	55.5	95	117.2	106.1	20	01
		L							
<b>019</b>	R	L	20VM	58.5	101	123.2	112.1	20	01
		L							
<b>022</b>	R	L	20VM	61.5	107	129.2	118.1	20	-
		L							

▼ Port 01, line thread according to ISO 228-1

NG	Suction port S	Pressure port P
<b>006, 008, 011, 013</b>	G3/4; 16 deep	G1/2; 14 deep
<b>016, 019</b>	G1; 18 deep	G1/2; 14 deep

▼ Driver

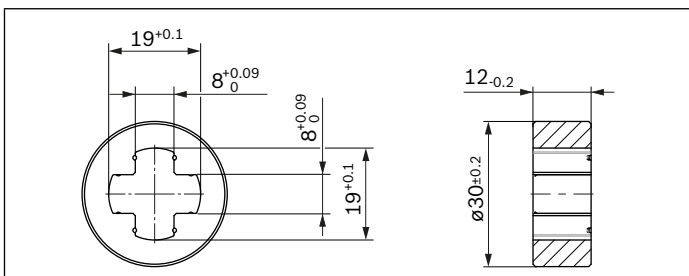

The driver (material number R900981428) is included in the scope of supply.

▼ Port 20, square flange port

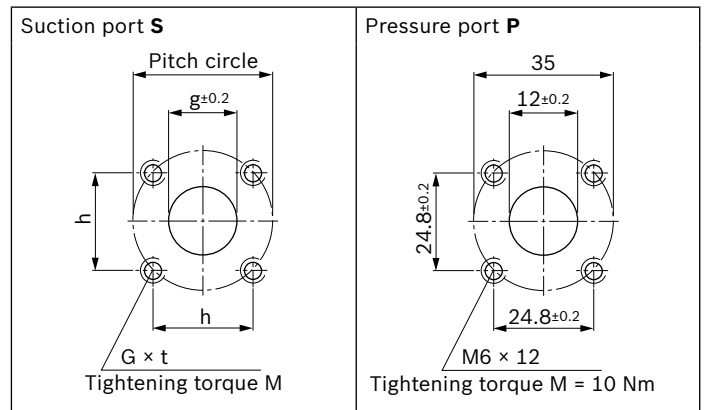

NG	g	h	Pitch circle	G	t	M [Nm]
<b>006, 008, 011, 013, 016</b>	20	28.3±0.2	40	M6	10	10
<b>019, 022</b>	26	38.9±0.3	55	M8	12	25

**Parallel keyed shaft, DIN 6885, without through drive**

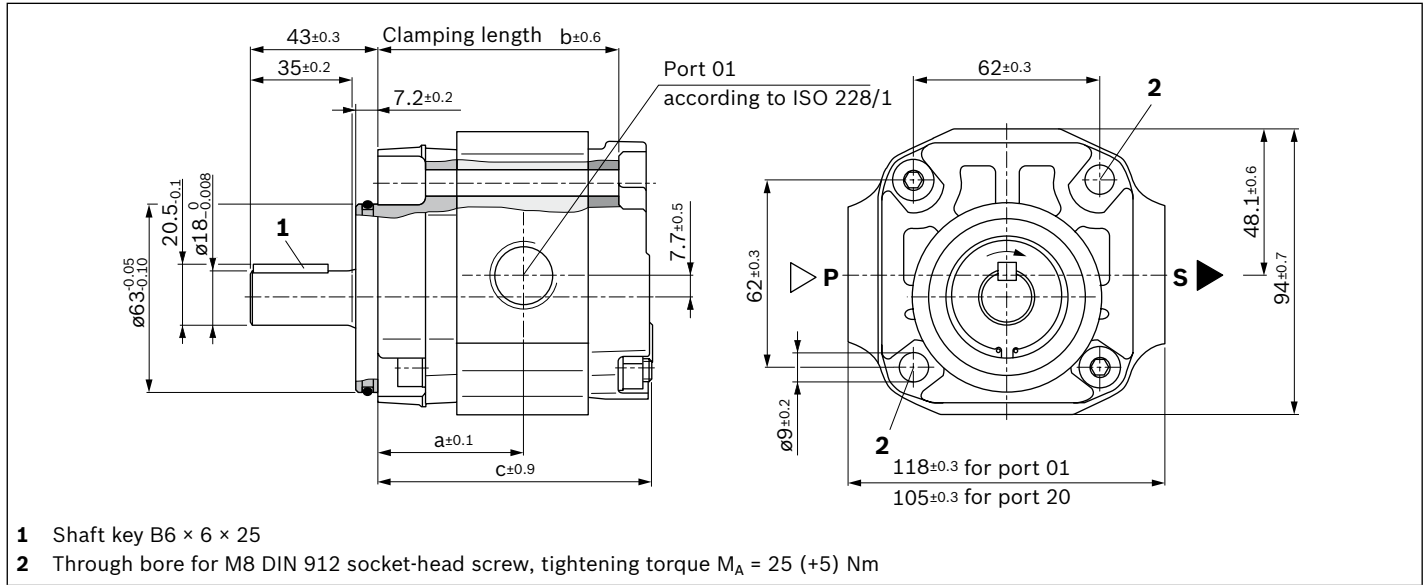

Type	Material numbers	a	b	c	Port standard	Port optional
PGF2-2X/ <b>006 R A</b> 01VP2	R900932272	46	76	87.2	01	20
<b>008 R A</b> 01VP2	R900564037	47.8	79.5	90.7	01	20
<b>011 R A</b> 01VP2	R900568523	50.5	85	96.2	01	20
<b>013 R A</b> 20VP2	R900032712	53	90	101.2	20	01
<b>016 R A</b> 20VP2	R900932275	55.5	95	106.2	20	01
<b>019 R A</b> 20VP2	R900571401	58.5	101	112.2	20	01

▼ **Port 01, line thread according to ISO 228-1**

NG	Suction port S	Pressure port P
<b>006, 008, 011, 013</b>	G3/4; 16 deep	G1/2; 14 deep
<b>016, 019</b>	G1; 18 deep	G1/2; 14 deep

▼ **Port 20, square flange port**

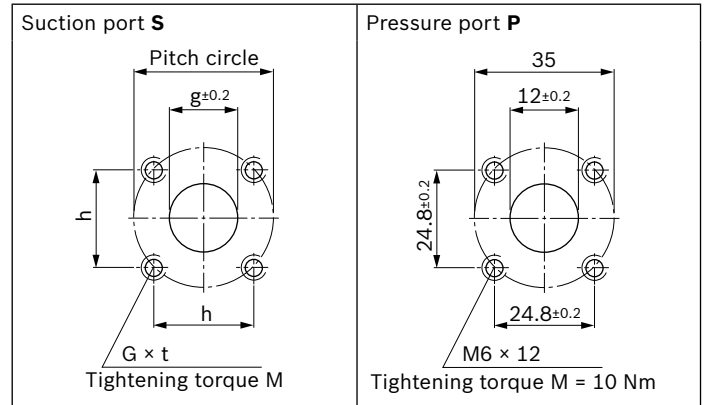

NG	g	h	Pitch circle	G	t	M [Nm]
<b>006, 008, 011, 013, 016</b>	20	$28.3 \pm 0.2$	40	M6	10	10
<b>019, 022</b>	26	$38.9 \pm 0.3$	55	M8	12	25

**Parallel keyed shaft, DIN 6885, with through drive**

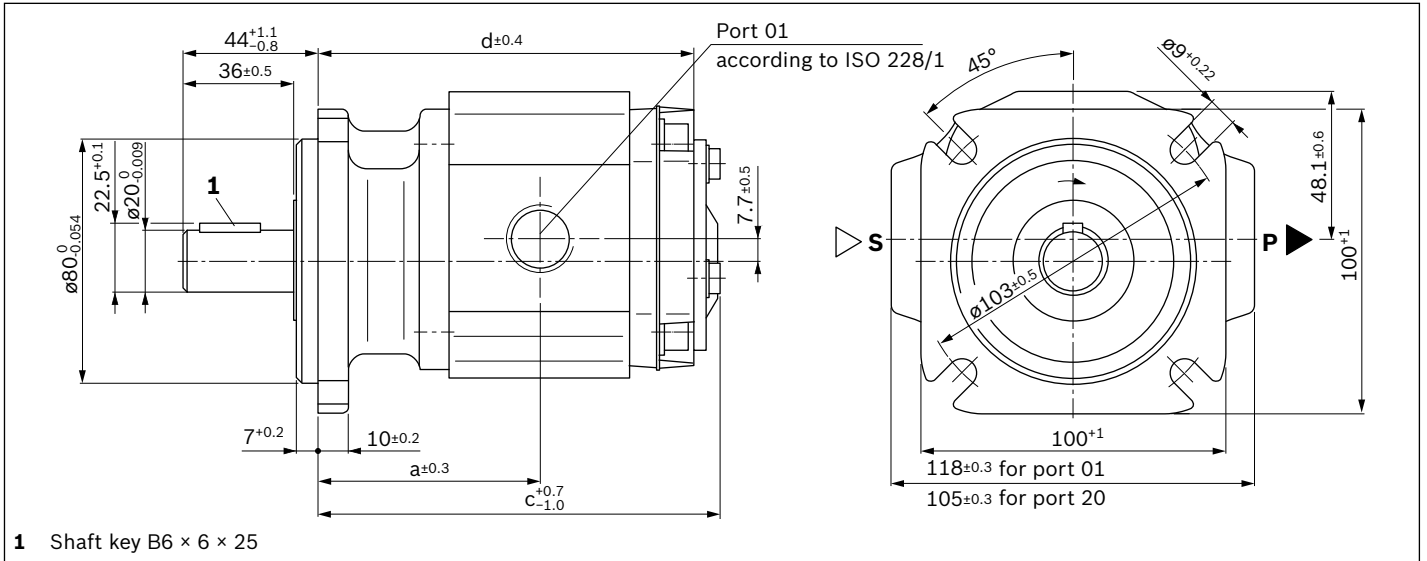

Type	Material numbers	a	c	d	Port standard	Port optional
PGF2-2X/ <b>006</b> R E 01VE4	R900932265	63	115.2	104.1	01	20
<b>008</b> R E 01VE4	R900932266	64.8	118.7	107.6	01	20
<b>011</b> R E 01VE4	R900932271	67.5	124.2	113.1	01	20
<b>013</b> R E 20VE4	R900943181	70	129.2	118.1	20	01
<b>016</b> R E 20VE4	R900932193	72.5	134.2	123.1	20	01
<b>019</b> R E 20VE4	R900943182	75.5	140.2	129.1	20	01
<b>022</b> R E 20VE4	R900932126	78.5	146.2	135.1	20	-

▼ **Port 01, line thread according to ISO 228-1**

NG	Suction port S	Pressure port P
<b>006, 008, 011, 013</b>	G3/4; 16 deep	G1/2; 14 deep
<b>016, 019</b>	G1; 18 deep	G1/2; 14 deep

▼ **Port 20, square flange port**

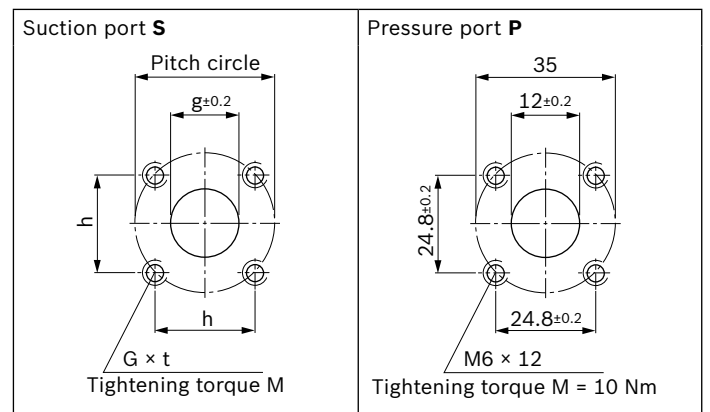

NG	g	h	Pitch circle	G	t	M [Nm]
<b>006, 008, 011, 013, 016</b>	20	28.3±0.2	40	M6	10	10
<b>019, 022</b>	26	38.9±0.3	55	M8	12	25

**Splined shaft, with through drive**

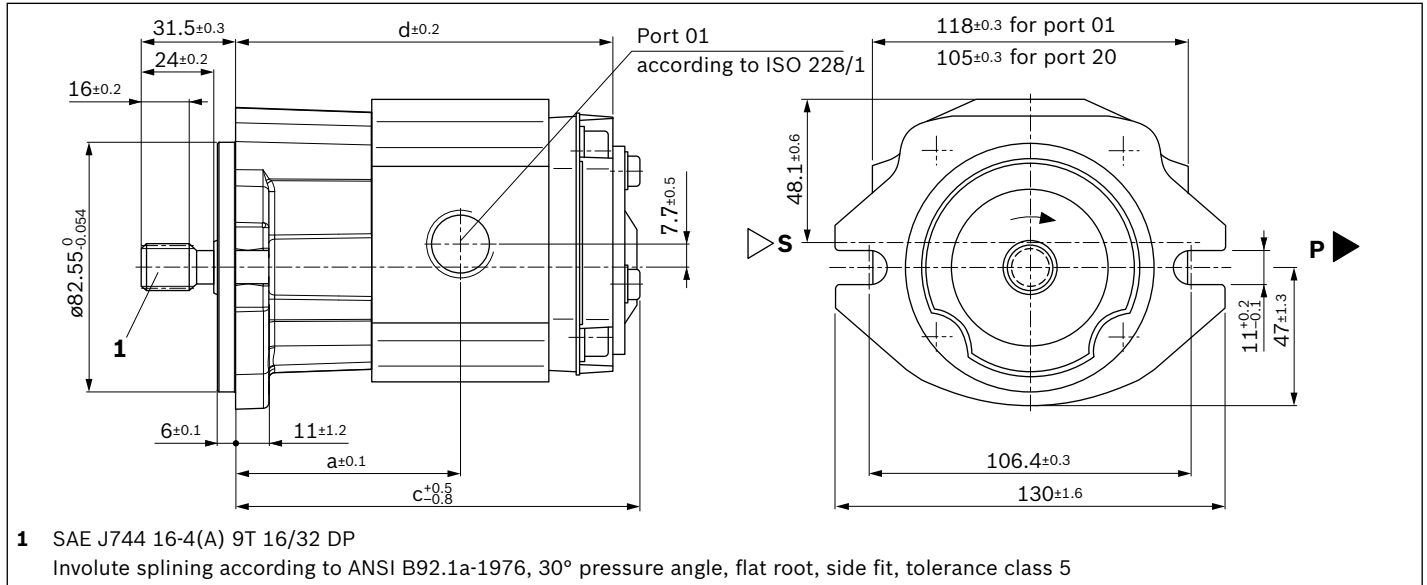

Type	Material numbers	a	c	d	Port standard	Port optional	
PGF2-2X/006	R J 01VU2	R900931660	65	117.2	106.1	01	20
	L	R900247697					
008	R J 01VU2	R900953363	66.8	120.7	109.6	01	20
	L	R900247698					
011	R J 01VU2	R900938281	69.5	126.2	115.1	01	20
	L	R900247699					
013	R J 20VU2	R900932264	72	131.2	120.1	20	01
	L	R900969259					
016	R J 20VU2	R900932085	74.5	136.2	125.1	20	01
	L	R900936173					
019	R J 20VU2	R900022882	77.5	142.2	131.1	20	01
	L	R900984300					
022	R J 20VU2	R900054053	80.5	148.2	137.1	20	-
	L	R900935718					

▼ **Port 01, line thread according to ISO 228-1**

NG	Suction port S	Pressure port P
006, 008, 011, 013	G3/4; 16 deep	G1/2; 14 deep
016, 019	G1; 18 deep	G1/2; 14 deep

▼ **Port 20, square flange port**

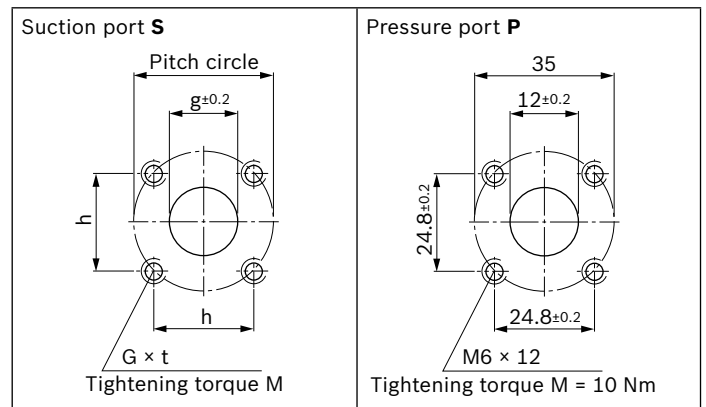

NG	g	h	Pitch circle	G	t	M [Nm]
006, 008, 011, 013, 016	20	28.3±0.2	40	M6	10	10
019, 022	26	38.9±0.3	55	M8	12	25



### Dimensions frame size 3

#### Splined shaft, with through drive

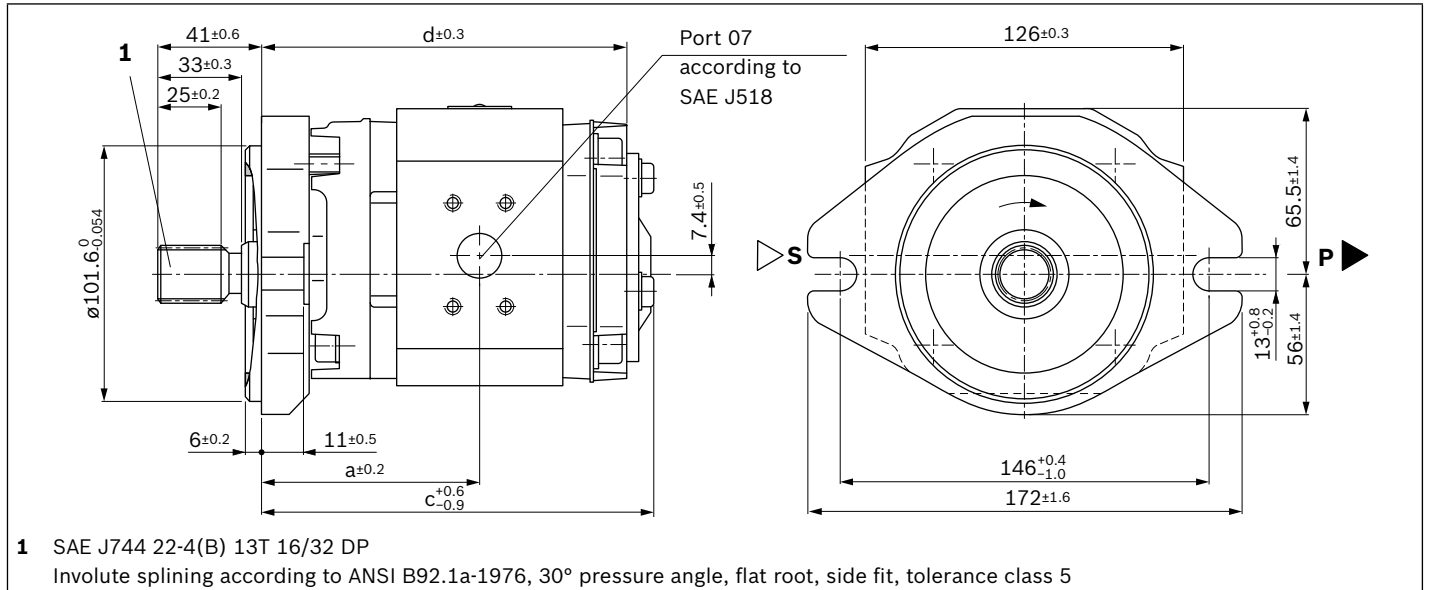

Type	Material numbers	a	c	d	Port standard	Port optional
PGF3-3X/ <b>020</b>	R J 07VU2	R900983792	79.5	145.6	07	20
	L	R900948466				
<b>025</b>	R J 07VU2	R900029617	82.5	151.6	07	20
	L	R900950057				
<b>032</b>	R J 07VU2	R900029561	87	160.6	07	20
	L	R900984213				
<b>040</b>	R J 07VU2	R900931426	92	170.6	07	-
	L	R900969266				

#### ▼ Port 07, suction and pressure port according to SAE J518

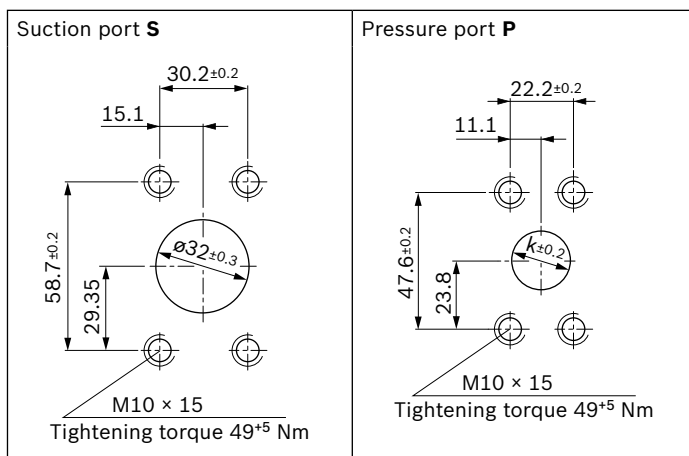

NG	k	Suction port S	Pressure port P
<b>020, 025</b>	16	1 1/4 in	3/4 in
<b>032, 040</b>	20	1 1/4 in	3/4 in

#### ▼ Port 20, square flange port

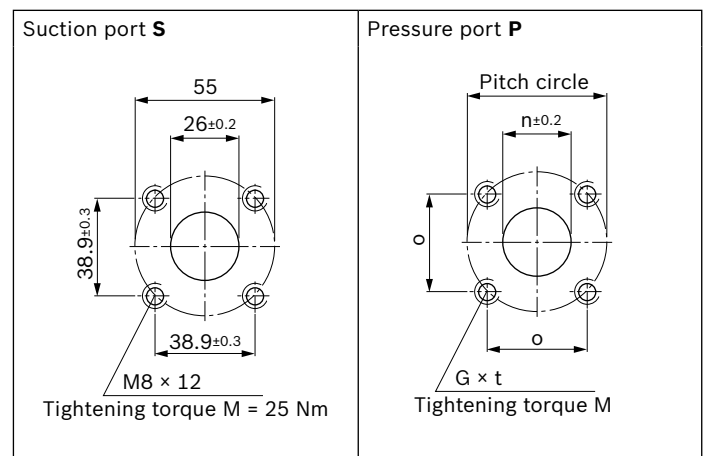

NG	n	o	Pitch circle	G	t	M [Nm]
<b>020, 025</b>	12	24.8±0.2	35	M6	10	10
<b>032</b>	20	38.9±0.3	55	M8	12	25

**Parallel keyed shaft, DIN 6885, without through drive**

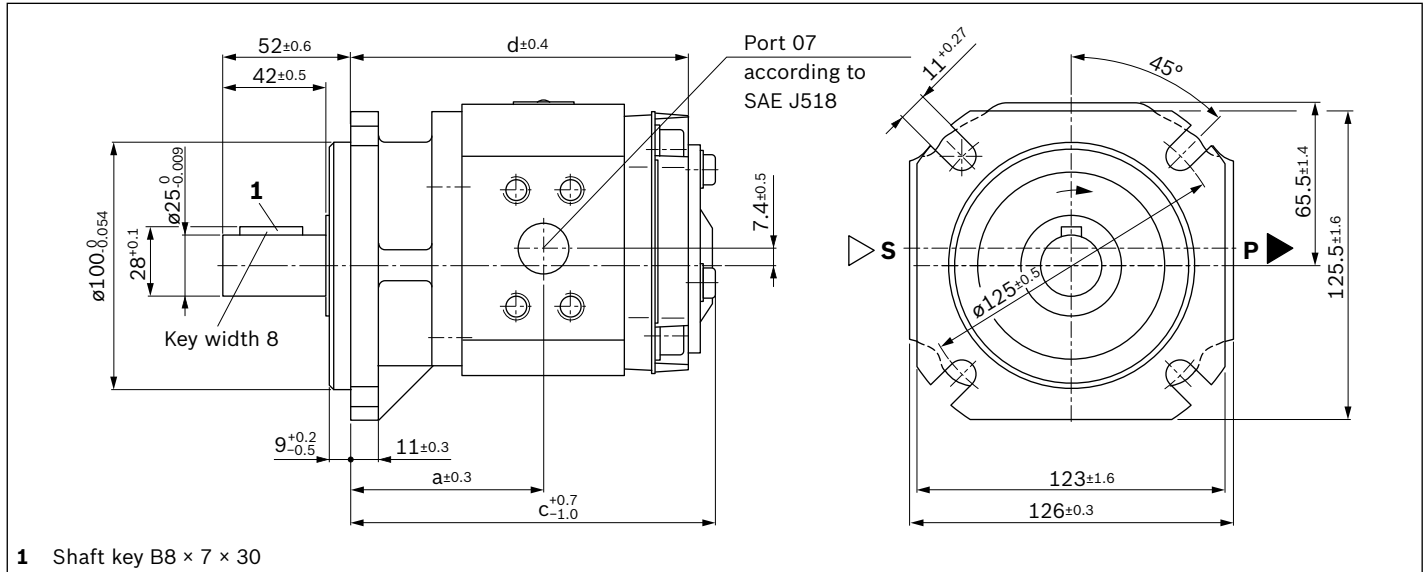

Type	Material numbers	a	c	d	Port standard	Port optional
PGF3-3X/ <b>020 R E</b> 07VE4	R900063299	71	137.1	126	07	20
<b>025 R E</b> 07VE4	R900932088	74	143.1	132	07	20
<b>032 R E</b> 07VE4	R900932112	78.5	152.1	141	07	20
<b>040 R E</b> 07VE4	R900932111	83.5	162.1	151	07	-

▼ **Port 07, suction and pressure port according to SAE J518**

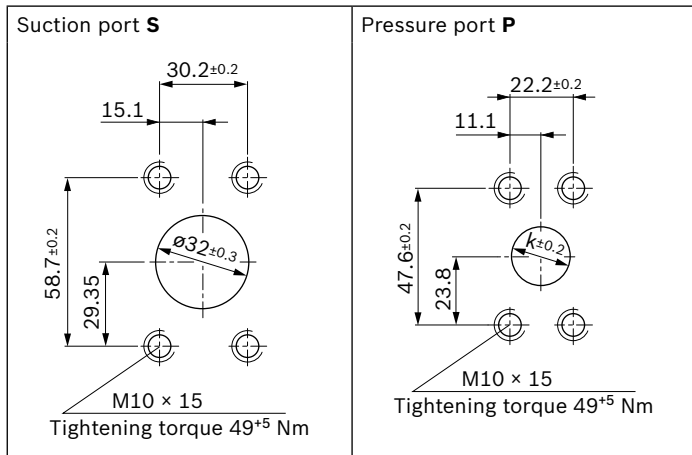

NG	k	Suction port S	Pressure port P
<b>020, 025</b>	16	1 1/4 in	3/4 in
<b>032, 040</b>	20	1 1/4 in	3/4 in

▼ **Port 20, square flange port**

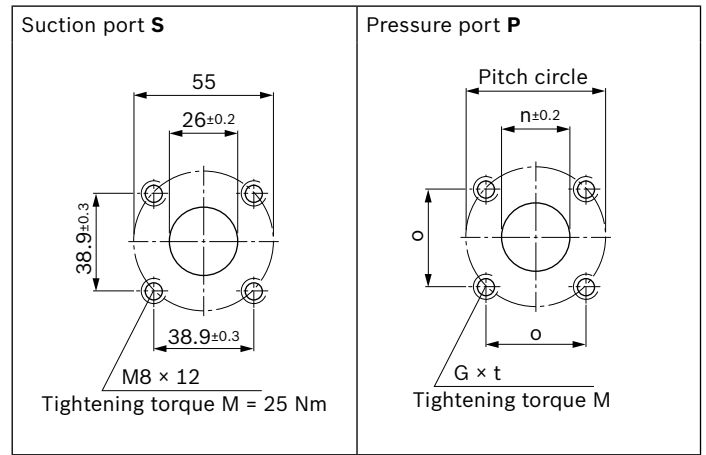

NG	n	o	Pitch circle	G	t	M [Nm]
<b>020, 025</b>	12	24.8±0.2	35	M6	10	10
<b>032</b>	20	38.9±0.3	55	M8	12	25

**Shaft for open-jaw coupling, with through drive, middle or rear pump**

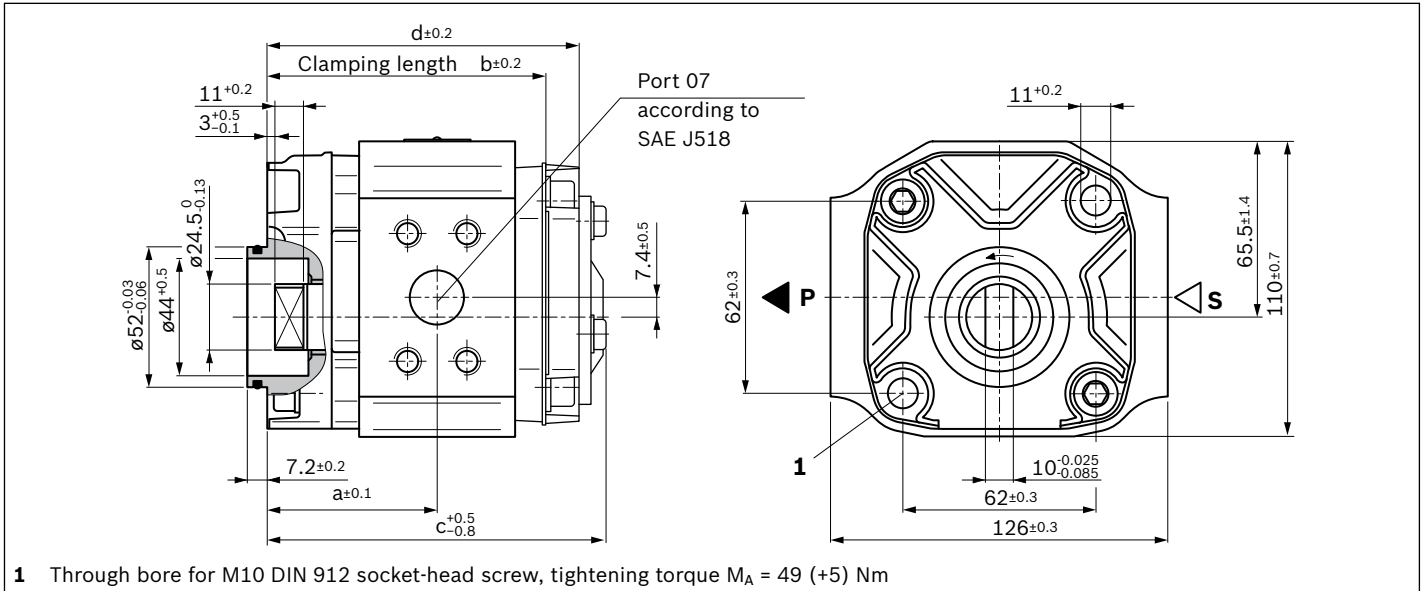

1 Through bore for M10 DIN 912 socket-head screw, tightening torque  $M_A = 49 (+5)$  Nm

Type	Material numbers	a	b	c	d	Port standard	Port optional	
PGF3-3X/ <b>020</b>	R L 07VM	R900073539	60.5	99.5	126.6	115.5	07	20
	L	R900758721						
<b>025</b>	R L 07VM	R900932121	63.5	105.5	132.6	121.5	07	20
	L	R900960119						
<b>032</b>	R L 07VM	R900074369	68	114.5	141.6	130.5	07	20
	L	R900034370						
<b>040</b>	R L 07VM	R900083281	73	124.5	151.6	140.5	07	-
	L	R900058224						

▼ **Port 07, suction and pressure port according to SAE J518**

▼ **Port 20, square flange port**

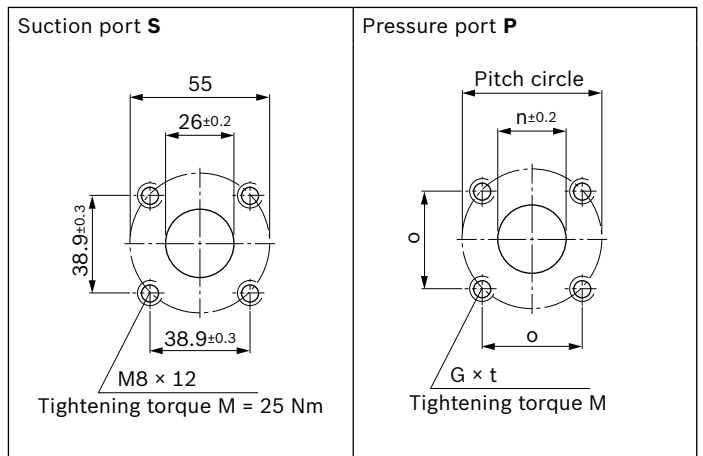
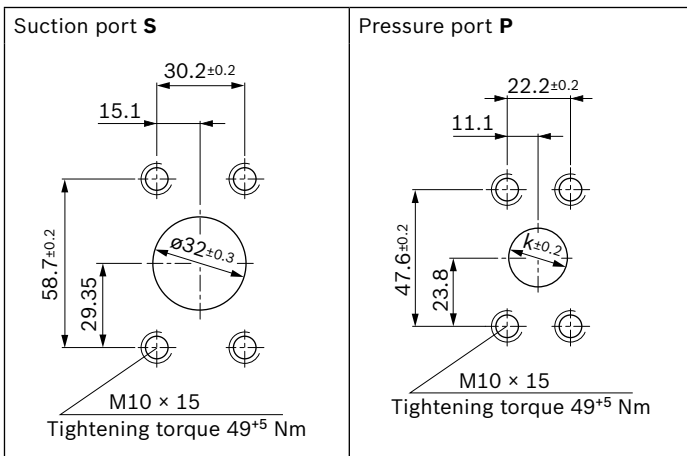

NG	k	Suction port S	Pressure port P
<b>020, 025</b>	16	1 1/4 in	3/4 in
<b>032, 040</b>	20	1 1/4 in	3/4 in

NG	n	o	Pitch circle	G	t	M [Nm]
<b>020, 025</b>	12	24.8±0.2	35	M6	10	10
<b>032</b>	20	38.9±0.3	55	M8	12	25

Driver see page 20

▼ **Driver**

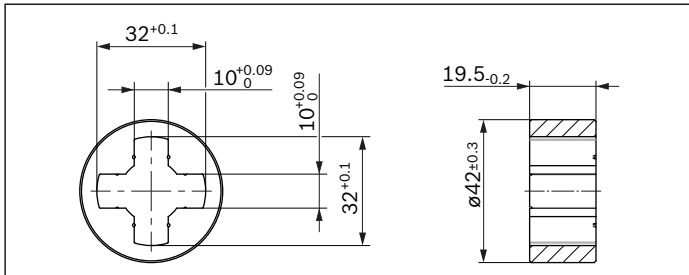

The driver (material number R900983603) is included in the scope of supply.

**Tapered shaft, with through drive**

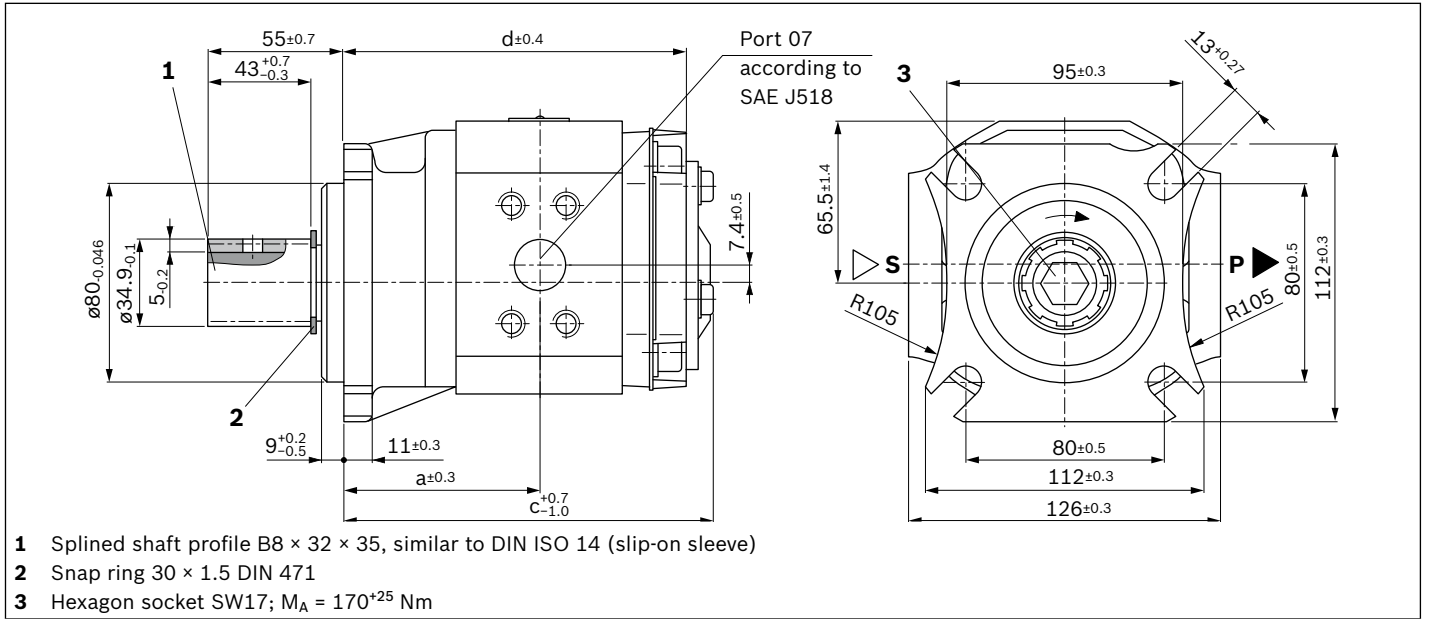

Type	Material numbers	a	c	d	Port standard	Port optional	
PGF3-3X/ <b>020</b>	R <b>07VK4</b>	R900969302	71	137.1	126	07	20
	L	R900619706					
<b>025</b>	R <b>07VK4</b>	R900943169	74	143.1	132	07	20
	L	R900619710					
<b>032</b>	R <b>07VK4</b>	R900943168	78.5	152.1	141	07	20
	L	R900943167					

▼ **Port 07, suction and pressure port according to SAE J518**

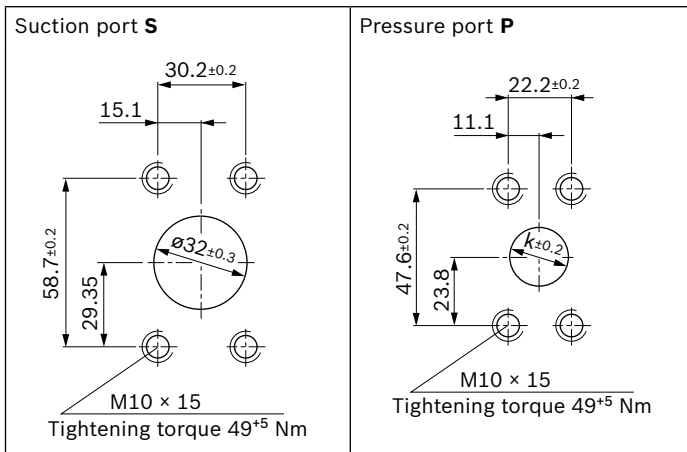

▼ **Port 20, square flange port**

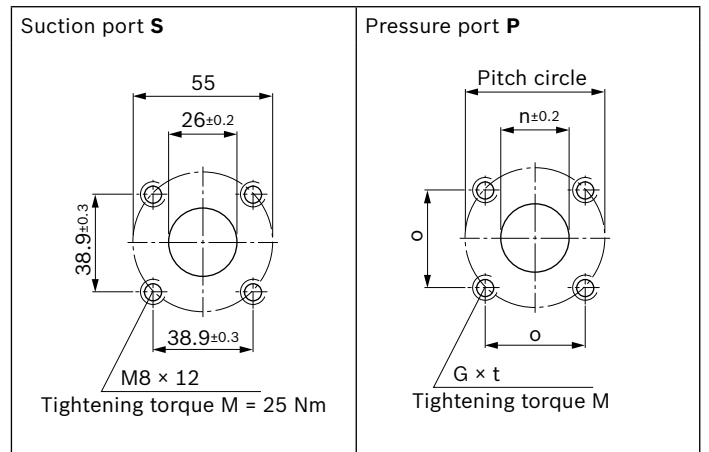

NG	k	Suction port S	Pressure port P
<b>020, 025</b>	16	1 1/4 in	3/4 in
<b>032</b>	20	1 1/4 in	3/4 in

NG	n	o	Pitch circle	G	t	M [Nm]
<b>020, 025</b>	12	24.8±0.2	35	M6	10	10
<b>032</b>	20	38.9±0.3	55	M8	12	25

## Multiple pump units

### Ordering code

01	02	03	04	05	06	07	08	09	10	11	12	13								
<b>P3</b>	<b>GF2</b>	<b>/</b>	<b>022</b>	<b>+</b>	<b>GF2</b>	<b>/</b>	<b>011</b>	<b>+</b>	<b>GF1</b>	<b>/</b>	<b>2.8</b>				<b>+</b>		<b>+</b>			

### Type

01	2-fold	<b>P2</b>
	3-fold	<b>P3</b>

02	Series of the first pump <sup>1)</sup>	
----	--	--

03	Size of the first pump <sup>1)</sup>	
----	--------------------------------------	--

04	Series of the second pump <sup>1)</sup>	
----	---	--

05	Size of the second pump <sup>1)</sup>	
----	---------------------------------------	--

06	Series of the third pump <sup>1)</sup>	
----	--	--

07	Size of the third pump <sup>1)</sup>	
----	--------------------------------------	--

### Direction of rotation

08	Viewed on drive shaft	clockwise	<b>R</b>
		counter-clockwise	<b>L</b>

### Drive shaft of the first pump

09	Parallel keyed shaft, ISO 3019-2 with through drive	<b>E</b>
	Splined shaft to SAE J744 with involute tooth system according to ANSI B92.1a	<b>J</b>
	Two surfaces for open-jaw coupling with through drive	<b>L</b>

### Wire connections for the first pump

10	Pipe thread according to ISO 228-1	<b>01</b>
	Suction and pressure port according to SAE J518	<b>07</b>
	Square flange port, metric fastening thread	<b>20</b>

### Wire connections for the second pump

11	Pipe thread according to ISO 228-1	<b>01</b>
	Suction and pressure port according to SAE J518	<b>07</b>
	Square flange port, metric fastening thread	<b>20</b>

### Wire connections for the third pump

12	Pipe thread according to ISO 228-1	<b>01</b>
	Suction and pressure port according to SAE J518	<b>07</b>
	Square flange port, metric fastening thread	<b>20</b>

### Mounting flange of the first pump

13	Special flange according to ISO 7653-1985 (for truck power take-off)	<b>K4</b>
	4-hole mounting flange according to ISO 3019-2 and VDMA 24560 Part 1	<b>E4</b>
	2-hole mounting flange according to ISO 3019-1	<b>U2</b>
	2-hole mounting flange, spigot diameter 32 mm (BG1), spigot diameter 52 mm (BG2 and BG3)	<b>M</b>
	2-hole mounting flange, spigot diameter 50 mm	<b>P</b>

1) Detailed information see ordering code page 2

## General project planning notes

### Intended use

Internal gear pumps are intended for the assembly of hydraulic drive systems in machine and system construction.

### Technical data

The system or machine manufacturer must ensure compliance with the permissible technical data and operating conditions. The pump itself does not contain a device to prevent operation outside the permissible data. It is possible to operate the pump outside of the permissible technical data to a certain extent; the express written consent from Bosch Rexroth is, however, required.

All specified technical performance features are median values and apply with the specified general conditions. In case of modifications to the general conditions (e.g., viscosity), the technical data may change as well. Scatter corresponding to the relevant state of technology is possible.

## Hydraulic project planning

### Air bleeding option for commissioning

For Rexroth PGF.-2/3X internal gear pumps, a manual or switchable air bleeding option for the initial commissioning or any recommissioning after maintenance and repair work is to be provided. The air bleeding point is to be set in the pressure line before the first valve or check valve. Air bleeding may be performed with a maximum counter pressure of 0.2 bar.

### Examples of air bleeding circuits

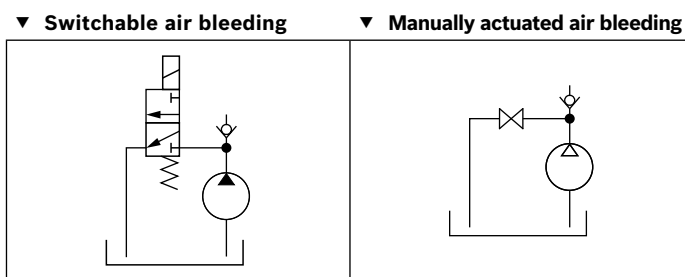

### Suction line

The line cross sections are to be dimensioned for the specified flows such that an ideal suction speed of 0.6 to 1.2 m/s is achieved on average. The suction speed should not exceed a maximum value of 2 m/s.

The suction cross sections at the pump itself are designed for the maximum flow and therefore serve only as reference. In case of continuous operation at rotational speeds lower than the permissible maximum speed, the suction tube diameter is also to be dimensioned smaller than the suction port of the pump depending on the actual suction speed.

Overall, the suction line is to be designed so that the permissible inlet operating pressure is maintained. Bends and a combination of suction lines from several pumps are to be avoided. If the use of a suction filter is unavoidable, it must be ensured on the system side that the lowest permissible inlet operating pressure is not exceeded even if the filter is contaminated.

Ensure the air tightness of the transitions and the pressure resistance of the suction hose with respect to the external air pressure.

The immersion depth of the suction pipe should be selected as large as possible (at least 100 mm at the lowest fluid level). Depending on the internal reservoir pressure, the viscosity of the operating medium and the flow conditions within the reservoir, no vortex may form even at maximum flow. There is otherwise a risk of air being drawn in. Return fluid and case drain fluid must not be immediately be drawn in again.

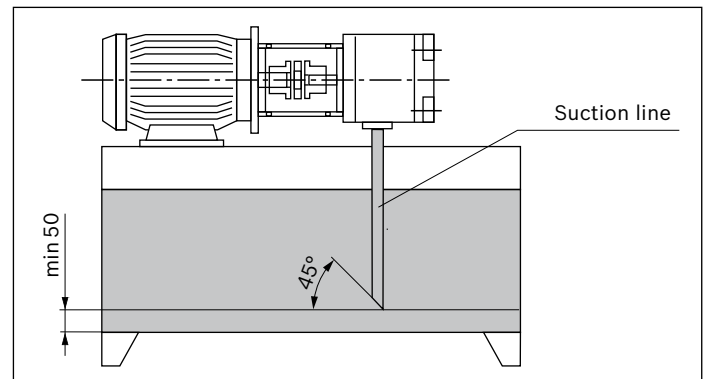

### **Pressure line**

Sufficient burst resistance of the pipes, hoses and connecting elements must be ensured for pressure lines. The cross sections should be based on the maximum flow in order to avoid additional excessive loading of the pump due to back-pressure. Here, you must also take into account the pipe losses over the entire pressure line length and other line resistances (e.g., bends, pressure filters).

### **Pressure safeguarding**

The PGF internal gear pump does not include any devices for adherence to the maximum operating pressure. The setting and safeguarding of the permissible operating pressure must be ensured on the system side.

The pressure-relief valves necessary for this purpose are to be designed with consideration given to the maximum flow and the rate of pressure increase that will occur such that the permissible intermittent operating pressure is not exceeded.

### **Pressure holding function**

In the variable-speed drive, the pump can also be temporarily operated in the pressure holding function below the specified minimum rotational speed. The holding time and the rotational speed necessary for this purpose are a function of the operating viscosity and the pressure level. For the design, please contact Bosch Rexroth's technical sales department.

In the deactivated state (rotational speed = 0), a leakage flow flows through the pump back into the reservoir, depending on the load pressure. If this is to be prevented, a check valve is to be used.

When using a check valve, please observe the note on the air bleeding option for commissioning, page 23.



## Mechanical project planning

### Mounting

On the machine side, the screws are to be accessible in such a way that the required tightening torque can be applied. The screw tightening torque is oriented towards the operating conditions and elements involved in the screw connection and is to be specified by the manufacturer during project planning of the power unit, the machine, or the system.

### Reservoir

When designing the reservoir or selecting a suitable standard reservoir, the following requirements are to be observed:

- ▶ Select the largest possible reservoir volume, depending on the continuous or average flow, which is needed in order to allow separation of air bubbles by means of sufficient dwell time of the medium in the reservoir. The air separation ability of the used hydraulic fluid is also of importance here.
- ▶ Provide settling zones for the hydraulic fluid in the reservoir in order to allow for air separation.
- ▶ Provide guiding plates in order to allow contamination at the reservoir bottom to be deposited outside the pump suction area.
- ▶ Generously dimension the reservoir surfaces depending on the heat output to be dissipated via the reservoir walls.

### Required power unit functions

At a minimum, the hydraulic power units should be equipped with the following features:

- ▶ Reservoirs that are designed so that the internal pressure corresponds to the ambient pressure should be equipped with ventilation filters for pressure compensation purposes.
- ▶ The hydraulic fluid should only be filled using filling nozzles that eliminate the possibility of filling with unfiltered fluid.
- ▶ The ingress of contamination or moisture must be avoided. If used in highly contaminated environments, the reservoir must, for this purpose, be precharged by means of air pressure. If cleaning of the reservoir exterior is planned or anticipated during the period of use, reservoir bushings for pipes, lines, or hoses are to be selected so that a secure seal is ensured against external pressurization with a water jet.

### Place of installation and ambient conditions

With places of installation at a geodetic height of more than 1000 m, the pump is to be arranged in or below the reservoir or the reservoir is to be precharged by means of compressed air in order to ensure the permissible minimum inlet pressure. A short suction line with large cross section is to be selected; bends should not be used.

When installing the pump more than 10 m below the reservoir, the reduction of the inlet pressure to the maximum permissible value must be ensured by means of additional measures.

If operating the pump in salt-containing or corrosive environments or if there is a possibility of pressurization with strongly abrasive substances, it must be ensured on the system side that the shaft seal ring and the sealing area of the shaft do not make direct contact with the environment.

### Drive

Electric motor + pump support + coupling + pump

- ▶ No radial or axial forces permissible on the pump drive shaft!
- ▶ Motor and pump must be exactly aligned!
- ▶ Always use a coupling that is suitable for compensating for shaft offsets!

### Installation positions

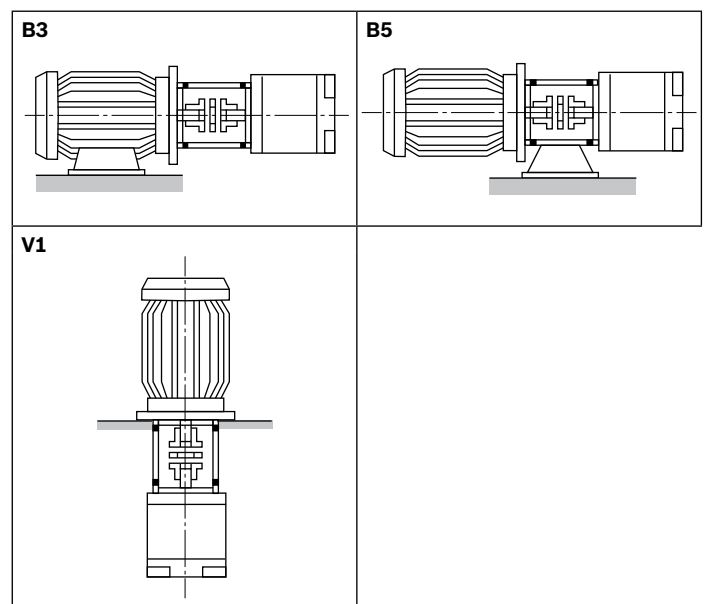

### Pump combinations

- ▶ With pump combinations, make sure that the operating data approved for the pump type concerned can be complied with in every step.
- ▶ Combined pumps must all have the same direction of rotation.
- ▶ The pump with the highest torque, variable pumps or pumps with intermittent pressure loading should be specified as the first step in the pump combination.
- ▶ The engineer must verify the maximum through-drive torque for every application. This also applies for existing (coded) pump combinations.
- ▶ The sum of all input torques in a pump combination may not exceed the permissible input torque of the first pump.

#### ▼ Maximum input torque [Nm]

Shaft	N	L	A	E	J	O
PGF1	14	14	30	30	–	–
PGF2	70	70	95	140	90	–
PGF3	140	140	–	230	230	260

#### ▼ Formula for input torque

$$T = \frac{\Delta p \times V \times 0.0159}{\eta_{\text{hydr.-mech.}}} \quad [\text{Nm}]$$

Key

- $T$  = Input torque [Nm]
- $\Delta p$  = Operating pressure [bar]
- $V$  = Displacement [cm<sup>3</sup>]
- $\eta$  = Hydraulic mechanical efficiency

#### ▼ Maximum output torque [Nm]

Shaft	L	E	J
PGF1	14	14	–
PGF2	70	70	70
PGF3	140	140	140

- ▶ Common suction is not possible.
- ▶ For reasons of strength and stability, we recommend using ISO 4-hole mounting flanges according to VDMA "E4" for combinations of three or more pumps
- ▶ Before operating pump combinations with different media, please consult Bosch Rexroth.
- ▶ PGF combinations are installed without combination parts and are not sealed against each other.

### Selection

- ▶ The front pump must have shaft version **E, J** or **L**.
- ▶ The middle pump must have shaft version **L**.
- ▶ The rear pump must have shaft version **N**.
- ▶ If a pump of the next smaller frame size is to be mounted, the designation of the first pump must end with "**K**" (e.g., PGF3 + PGF2 ⇒ front pump: PGF3-3X/032RJ07VU2K)

### Dimensions

- ▶ The dimensions of the ports are the same as for single pumps (see page 9 to 20).
- ▶ The total length of the pump combination is calculated by adding up dimensions "d" of the single pumps (see pages 9 to 20)
- ▶ With the combination of PGF2 and PGF1, the installation length of the PGF2 (dimension d) increases by 4.5 mm. With the combination of PGF3 and PGF2, the installation length of the PGF3 (dimension d) increases by 2 mm. With the combination of PGF3 and PGF1, the installation length of the PGF3 (dimension d) increases by 12.5 mm.

## Maintenance schedule and operational safety

For safe operation and a long service life of the pump, a maintenance schedule must be prepared for the power unit, the machine, or the system. The maintenance schedule must ensure that the specified or permissible operating conditions of the pump are complied with over the entire period of use.

In particular, compliance with the following operating parameters is to be ensured:

- ▶ The required oil cleanliness
- ▶ The operating temperature range
- ▶ The filling level of the operating medium

Furthermore, the pump and the system are to be checked for changes to the following parameters on a regular basis:

- ▶ Vibrations
- ▶ Noise
- ▶ Temperature difference between pump – fluid in the reservoir
- ▶ Foaming in the reservoir
- ▶ Leak-proofness

Changes to these parameters indicate component wear (e.g., diesel engine, coupling, pump, etc.). The reason is to be determined and remedied immediately.

In order to achieve high operational safety of the pump in the machine or system, we recommend checking the aforementioned parameters continuously and automatically and the automatic shut-down in case of changes exceeding the usual fluctuations in the specified operating range.

Plastic components of drive couplings should be replaced regularly, though after no more than 5 years. The corresponding manufacturer's specifications are paramount.

For preventive maintenance of the pump, we recommend having the seals replaced after an operating period of no more than 5 years by an authorized Bosch Rexroth service company.

## Accessories

### Pump safety block

For limiting the operating pressure and for the pump circulation at zero pressure, we recommend our pump safety blocks of type DBA... according to data sheet 25890.

Automatic air bleeding during commissioning is, however, not possible via DBA blocks. In this case, we recommend separate, manual air bleeding.

**Bosch Rexroth AG**

Mobile Applications  
Zum Eisengießer 1  
97816 Lohr am Main, Germany  
Tel. +49 9352 18-0  
info.ma@boschrexroth.de  
www.boschrexroth.com

© This document, as well as the data, specifications and other information set forth in it, are the exclusive property of Bosch Rexroth AG. It may not be reproduced or given to third parties without its consent. The data specified above only serve to describe the product. No statements concerning a certain condition or suitability for a certain application can be derived from our information. The information given does not release the user from the obligation of own judgment and verification. It must be remembered that our products are subject to a natural process of wear and aging.