

Axial Piston Variable Pump A4VBO

RE 92122/04.12 1/28
Replaces: 06.10

Data sheet

Series 10, 30
Size 71, 125, 450
Nominal pressure 450 bar
Maximum pressure 500 bar
Open circuit



Contents

| | |
|------------------------------------|----|
| Ordering code for standard program | 2 |
| Technical data | 4 |
| Characteristics | 9 |
| Control devices | 11 |
| Dimensions size 71 | 13 |
| Dimensions size 125 | 16 |
| Dimensions size 450 | 20 |
| Overview of attachments | 22 |
| Through drive dimensions | 23 |
| Installation instructions | 26 |
| General instructions | 28 |

Features

- Axial piston variable pump in swash plate design for hydrostatic drives in open circuit as well as operation with boosted inlet
- The flow is proportional to the input drive speed and displacement. By adjusting the swash plate angle it is possible to infinitely vary the output flow.
- Slot-controlled swash plate design
- Infinitely variable displacement
- Low noise level
- Long service life
- Axial and radial loading on the drive shaft
- Excellent power to weight ratio
- Modular design
- Short response times
- Visual swivel angle indicator
- Bearing flushing

Ordering code for standard program

| | | | | | | | | | | | | |
|-------------|----------|----|----|----------|----|----|----------|----|----------|----|-----------|----|
| A4VB | O | | | / | | | V | | - | | 25 | |
| 01 | 02 | 03 | 04 | | 05 | 06 | 07 | 08 | | 09 | 10 | 11 |

Axial piston unit

| | | | | | | | | | | | |
|----|--|--|--|--|--|--|--|--|--|--|-------------|
| 01 | Swash plate design, variable, nominal pressure 450 bar, maximum pressure 500 bar | | | | | | | | | | A4VB |
|----|--|--|--|--|--|--|--|--|--|--|-------------|

Type of operation

| | | | | | | | | | | | |
|----|--------------------|--|--|--|--|--|--|--|--|--|----------|
| 02 | Pump, open circuit | | | | | | | | | | O |
|----|--------------------|--|--|--|--|--|--|--|--|--|----------|

Size

| | | | | | | | | | | |
|----|---|--|--|--|--|--|--|------------|------------|------------|
| 03 | ≈ Displacement V_g max in cm^3 | | | | | | | 071 | 125 | 450 |
|----|---|--|--|--|--|--|--|------------|------------|------------|

Control devices

| | | | | | | | | | | | |
|----|--|--|--|--|--|--|------------|------------|------------|---|-------------|
| | | | | | | | 071 | 125 | 450 | | |
| 04 | Hydraulic control with proportional valve (see RE 92076) | | | | | | | ● | ● | ● | HS4 |
| | Electro-hydraulic control system DFE1 (see RE 92088) | | | | | | | ● | ● | - | DFE1 |

Series

| | | | | | | | | | | | |
|----|-------------------|--|--|--|--|--|------------|------------|------------|---|-----------|
| | | | | | | | 071 | 125 | 450 | | |
| 05 | Series 1, Index 0 | | | | | | | ● | - | - | 10 |
| | Series 3, Index 0 | | | | | | | - | ● | ● | 30 |

Direction of rotation

| | | | | | | | | | | |
|----|-------------------------|--|--|--|--|--|--|-------------------|--|----------|
| 06 | Viewed from drive shaft | | | | | | | clockwise | | R |
| | | | | | | | | counter clockwise | | L |

Seals

| | | | | | | | | | | | |
|----|------------------------|--|--|--|--|--|--|--|--|--|----------|
| 07 | FKM (fluor-caoutchouc) | | | | | | | | | | V |
|----|------------------------|--|--|--|--|--|--|--|--|--|----------|

Drive shaft

| | | | | | | | | | | | |
|----|---|--|--|--|--|--|------------|------------|------------|---|----------|
| | | | | | | | 071 | 125 | 450 | | |
| 08 | Splined shaft DIN 5480 without clearance groove | | | | | | | - | - | ● | R |
| | Splined shaft DIN 5480 | | | | | | | ● | ● | - | Z |

Mounting flange

| | | | | | | | | | | | | | |
|----|------------------------------|--|--|--|--|--|------------|------------|------------|---|---|---|----------|
| | | | | | | | 071 | 125 | 450 | | | | |
| 09 | Similar to ISO 3019-2 metric | | | | | | | 4-Loch | | ● | ● | - | B |
| | | | | | | | | 8-Loch | | - | - | ● | H |

Service line connections

| | | | | | | | | | | | |
|----|---|--|--|--|--|--|--|--|--|--|-----------|
| 10 | Port B and S on side 90° off set, fixing thread metric, 2. outlet port B1 opposite B - closed with blind plate on delivery | | | | | | | | | | 25 |
|----|---|--|--|--|--|--|--|--|--|--|-----------|

● = Available

○ = On request

- = Not available

□ = Preferred program

Ordering code for standard program

| | | | | | | | | | | | | |
|-------------|----------|----|----|----------|----|----|----------|----|----------|----|-----------|----|
| A4VB | O | | | / | | | V | | - | | 25 | |
| 01 | 02 | 03 | 04 | | 05 | 06 | 07 | 08 | | 09 | 10 | 11 |

| Through drive | | | 071 | 125 | 450 | | |
|---------------|--|---------------------------|--|-----|-----|---|------|
| 11 | With through drive for mounting an axial piston pump or gear unit | | | ● | ● | ● | K... |
| | Flange | Coupler for splined shaft | to mount | | | | |
| | 140, 4-bolt (ISO ¹⁾) | 40x2x18x9g | A4VBO, A4VSO, A4VSG 71 | | | | 33 |
| | 160, 4-bolt (ISO ¹⁾) | 50x2x24x9g | A4VBO, A4VSO, A4VSG 125; A4VSO, A4VSG 180 | | | | 34 |
| | 315, 8-bolt (ISO ¹⁾) | 80x3x25x9g | A4VBO 450 | | | | 97 |
| | 82-2 (SAE A) | 5/8in 16-4 (SAE A) | AZ-PF-1X-004...022 | | | | 01 |
| | 101-2 (SAE B) | 7/8in 22-4 (SAE B) | A10V(S)O 28/31(2)/52(3), AZ-PN-1X-020...032 | | | | 68 |
| | 101-2 (SAE B) | 1in 25-4 (SAE B-B) | A10V(S)O 45/31, A10V(S)O 45/52(3), PGH4 | | | | 04 |
| | 127-2 (SAE C) | 1 1/2in 38-4 (SAE C-C) | A10V(S)O 100/31, A10V(S)O 85/52(3), PGH5 | | | | 24 |
| | With through drive shaft, without coupler, without adaptor flange, closed with cover | | | ● | ● | ● | 99 |

1) To ISO 3019-2 metric

● = Available

○ = On request

- = Not available

☐ = Preferred program

Technical data

Hydraulic fluid

For extensive information on the selection of hydraulic fluids and application conditions please consult our data sheet RE 90220 (mineral oils) prior to system design.

The variable pump A4VBO is not suitable for operation on HFA, HFB and HFC fluids. For operation on HFD or ecologically acceptable fluids please consult us.

Operating viscosity range

Within the operating viscosity range between 16...100 mm²/s the unit can be operated without limitations of the technical data.

In order to obtain optimum efficiency and service life, we recommend that the operating viscosity (at operating temperature) lies in the range

$$v_{\text{opt}} = \text{opt. viscosity range } 16 \dots 36 \text{ mm}^2/\text{s}$$

referred to tank temperature (open circuit).

Limit of viscosity range

For critical operating conditions the following values apply:

- $v_{\text{min}} = 10 \text{ mm}^2/\text{s}$
for short periods ($t < 3 \text{ min}$)
at max. permissible case drain temperature
 $t_{\text{max}} = +90^\circ \text{ C}$.
- $v_{\text{max}} = 1000 \text{ mm}^2/\text{s}$
for short periods (on cold start maximum operating
viscosity of $100 \text{ mm}^2/\text{s}$ should be reached within 15
min)
 $t_{\text{min}} = -25^\circ \text{ C}$

For detailed information on operation with low temperatures see RE 90300-03-B.

Selection diagram

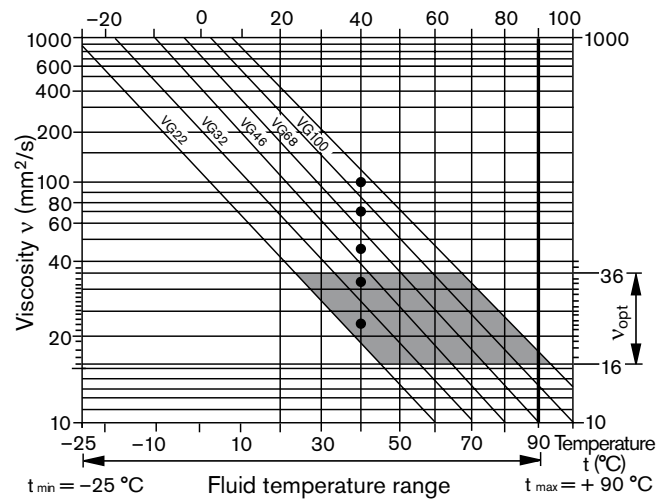

Notes on the selection of hydraulic fluid

In order to select the correct fluid, it is necessary to know the operating temperature in the tank (open circuit) in relation to the ambient temperature.

The hydraulic fluid should be selected so that within the operating temperature range, the viscosity lies within the optimum range (v_{opt}); see shaded section in the selection diagram. We recommend, that the higher viscosity grade is selected in each case.

Temperature range (see selection diagram)

$$t_{\text{min}} = -25^\circ \text{ C}$$

$$t_{\text{max}} = +90^\circ \text{ C}$$

Example: at an ambient temperature of $X^\circ \text{ C}$ the operating temperature in the tank is 60° C . In the optimum viscosity range (v_{opt} ; shaded area), this corresponds to grades VG 46 or VG 68; select: VG 68.

Important: The case drain temperature is influenced by pressure and speed and is always higher than the tank temperature. However the max. temperature at any point in the system may not exceed 90° C .

Technical data

Bearing flushing

For the following operating conditions bearing flushing is required for a safe, continuous operation:

- Operation at critical conditions of temperature and viscosity with mineral oil

Flushing is recommended with vertical mounting (drive shaft facing upwards) in order to ensure lubrication of the front bearing and shaft seal ring.

Flushing is carried out via port U, located in the front flange area of the pump. The flushing fluid flows through the front bearing and leaves the pump together with the case drain flow.

Depending on pump size, the following flushing flows are recommended:

| Size | 71 | 125 | 450 |
|--|----|-----|-----|
| recommended flushing flow q_{Sp} L/min | 4 | 5 | 20 |

These recommended flushing flows will cause a pressure drop of approx. 2 bar (series 10) and approx. 3 bar (series 30) between the entrance to port U and the pump case (including the pipe fittings).

Note regarding size 125

When using external bearing flushing the throttle screw at port U must be turned in to the end stop.

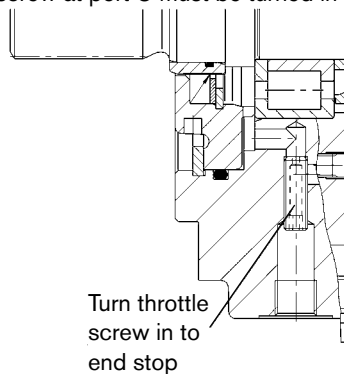

Note regarding size 450

In the size 450, the flushing fluid is taken out of the existing boost pressure source. When using an external flushing flow source, the throttle screw in port U must be turned out to a dimension of 20 mm.

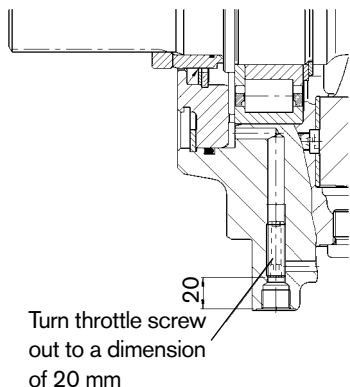

Filtration of the fluid (axial piston unit)

The finer the filtration, the better the achieved cleanliness of the fluid and the longer the life of the axial piston unit.

To ensure a reliable functioning of the axial piston unit, a minimum cleanliness class of 20/18/15 acc. to ISO 4406 is necessary.

Case drain pressure

The permissible case drain pressure (housing pressure) depends on the drive speed (see diagram).

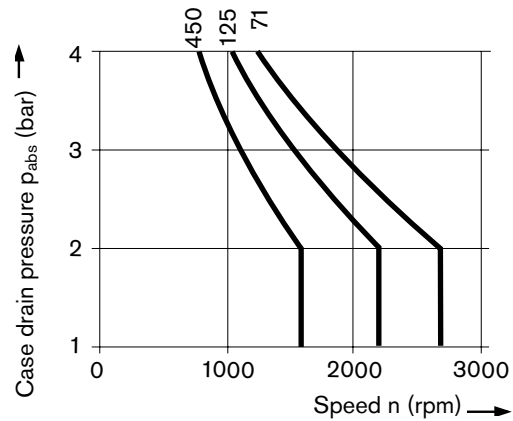

Max. case drain pressure (housing pressure)

$P_{L abs max}$ _____ 4 bar absolute

These figures are approx. values; under special operating conditions restrictions may be necessary.

Flow direction

S to B

Temperature range for the shaft seal ring

The FKM-shaft seal ring is suitable for case drain temperatures between -25 °C to +90 °C.

Hinweis

For applications below -25 °C a NBR-shaft seal ring must be used (permissible temperature range: -40 °C to +90 °C). NBR-shaft seal ring must be stated in clear text when ordering. Please consult us.

Technical data

Operating pressure range

Pressure at service line (pressure port) B

Nominal pressure p_{nom} _____ 450 bar absolute
 Maximum pressure p_{max} _____ 500 bar absolute
 Single operating period _____ 1 s
 Total operating period _____ 300 h

Minimum pressure (high pressure side) _____ 15 bar
 At lower pressures, please consult us.

Rate of pressure change R_A _____ 16000 bar/s

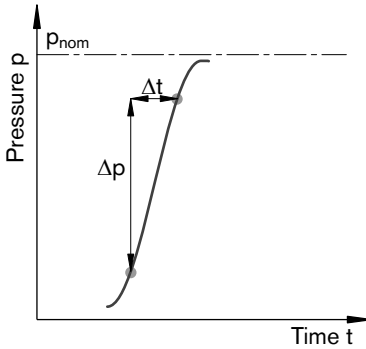

Size 71/125: pressure at suction port S (inlet)

Minimum inlet pressure $p_{S min}$ _____ 0.8 bar absolute
 Maximum inlet pressure $p_{S max}$ _____ 30 bar absolute

Size 71/125: minimum pressure (inlet)

In order to avoid damage to the axial piston unit, a minimum pressure must be ensured at the inlet suction port S (inlet). This minimum pressure is dependent on the speed and displacement of the axial piston unit.

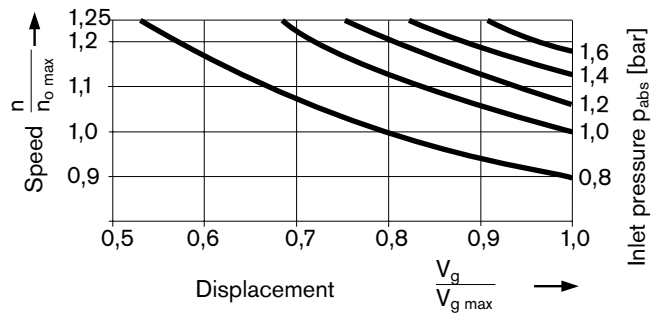

Size 450: pressure at suction port S (inlet)

Minimum suction pressure $p_{S min}$ _____ 5 bar absolute
 Maximum suction pressure $p_{S max}$ _____ 30 bar absolute

Boost pressure (at size 450 compulsory)

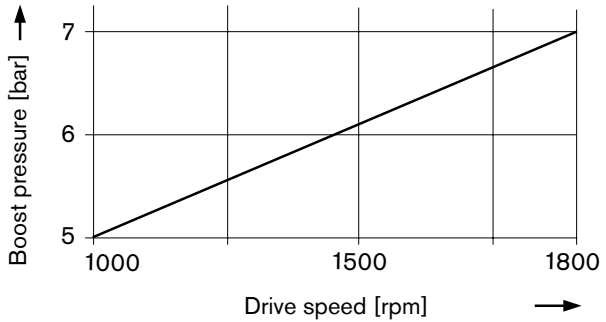

The inlet pressure is the static feed pressure or the minimum dynamic value of the boost pressure.

Please note:
 Max. permissible speed $n_{o max. zul.}$ (speed limit) see page 7

If the above conditions cannot be met, please consult us.

Definition

Nominal pressure p_{nom}

The nominal pressure corresponds to the maximum design pressure.

Maximum pressure p_{max}

The maximum pressure corresponds to the maximum operating pressure within the single operating period. The sum of the single operating periods must not exceed the total operating period.

Minimum pressure (high-pressure side)

Minimum pressure at the high-pressure side (A or B) which is required in order to prevent damage to the axial piston unit.

Rate of pressure change R_A

Maximum permissible rate of pressure build-up and pressure reduction during a pressure change over the entire pressure range.

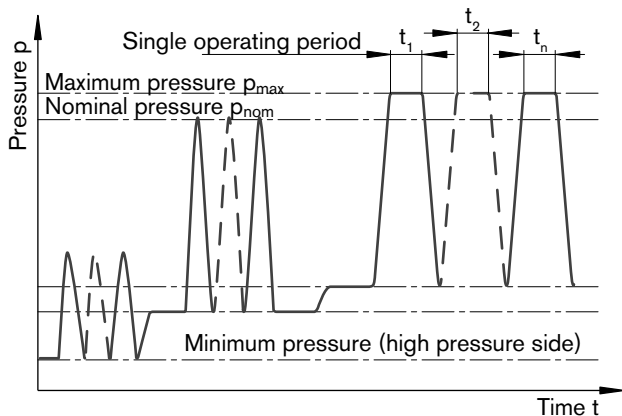

Total operating period = $t_1 + t_2 + \dots + t_n$

Technical data

Table of values (theoretical values, without efficiencies and tolerances; values rounded)

| Size | | | 71 | 125 | 450 |
|--|---------------------------|--------------------|--------|------|--------|
| Displacement | $V_{g \max}$ | cm ³ | 71 | 125 | 450 |
| Speed ¹⁾ | | | | | |
| max. at $V_{g \max}$ | $n_{o \max}$ | min ⁻¹ | 2200 | 1800 | 1800 |
| max. at $V_g \leq V_{g \max}$ (speed limit) | $n_{o \max \text{ zul.}}$ | min ⁻¹ | 2700 | 2200 | 1800 |
| Flow | | | | | |
| at $n_{o \max}$ | $q_{vo \max}$ | L/min | 156 | 225 | 810 |
| at $n_E = 1500$ rpm | $q_{vE \max}$ | L/min | 107 | 188 | 675 |
| Power $\Delta p = 450$ bar | | | | | |
| at $n_{o \max}$ | $P_{o \max}$ | kW | 117 | 169 | 608 |
| at $n_E = 1500$ min ⁻¹ | $P_{E \max}$ | kW | 80 | 141 | 506 |
| Torque | | | | | |
| at $V_{g \max}$ $\Delta p = 450$ bar | T_{\max} | Nm | 508 | 894 | 3220 |
| $\Delta p = 100$ bar | T | Nm | 113 | 199 | 716 |
| Torsional stiffness | | | | | |
| shaft R | c | kNm/rad | - | - | 1234 |
| shaft Z | c | kNm/rad | 146 | 263 | - |
| Moooment of inertia rotary group | J_{TW} | kgm ² | 0.0121 | 0.03 | 0.3325 |
| Angular acceleration max. ²⁾ | α | rad/s ² | 11000 | 8000 | 2800 |
| Filling capacity | V | L | 2.5 | 5 | 14 |
| Weight (with HS4) approx. | m | kg | 65 | 100 | 390 |

1) The values are valid for sizes 71 and 125 with an inlet pressure of $p_{\text{abs}} 1$ bar at suction port S, for increase of speed up to the speed limit observe the diagram on page 6. For the size 450 observe the diagram „Compulsory boost requirements“ on page 6.

2) The range of validity lies between the minimum required and the maximum permissible drive speeds.

Valid for external excitation (eg. diesel engine 2-8 fold rotary frequency, cardan shaft 2 fold rotary frequency).

The limiting value is only valid for a single pump.

The loading capacity of the connecting parts must be considered.

Note

Exceeding the maximum or minimum permissible values can lead to a loss of function, a reduction in operational service life or total destruction of the axial piston unit. The permissible values can be determined through calculation.

Determining the operating characteristics

$$\text{Flow} \quad q_v = \frac{V_g \cdot n \cdot \eta_v}{1000} \quad [\text{L/min}]$$

$$\text{Torque} \quad T = \frac{V_g \cdot \Delta p}{20 \cdot \pi \cdot \eta_{mh}} \quad [\text{Nm}]$$

$$\text{Power} \quad P = \frac{2\pi \cdot T \cdot n}{60000} = \frac{q_v \cdot \Delta p}{600 \cdot \eta_t} \quad [\text{kW}]$$

V_g = Displacement per revolution in cm³

Δp = Differential pressure in bar

n = Speed rpm



η_v = Volumetric efficiency

η_{mh} = Mechanical-hydraulic efficiency

η_t = Total efficiency ($\eta_t = \eta_v \cdot \eta_{mh}$)

Technical data

Permissible radial and axial loading on drive shaft

| Size | NG | 71 | 125 | 450 |
|----------------------|---|------|------|------|
| Radial force maximum |  $F_{q \max}$ N | 1200 | 1600 | 3000 |
| Axial force maximum |  $\pm F_{ax \max}$ N | 800 | 1000 | 2200 |

Note

Special requirements apply in the case of belt drives. Please contact us.

Force transfer direction of the permissible axial force:

+ $F_{ax \max}$ = Increase in service life of bearings

- $F_{ax \max}$ = Reduction in service life of bearings (avoid)

Permissible input and through-drive torques

| Size | NG | 71 | 125 | 450 |
|---|-----------------|-----|------|------|
| Torque at $V_{g \max}$ and $\Delta p = 450 \text{ bar}$ ¹⁾ | T_{\max} Nm | 508 | 894 | 3220 |
| Input torque for shaft end, maximum ²⁾ | | | | |
| R | $T_{E \max}$ Nm | - | - | 6440 |
| Z | $T_{E \max}$ Nm | 790 | 1392 | - |
| Through drive torque maximum | $T_{D \max}$ | 395 | 696 | 3220 |

1) Efficiency not considered

2) For drive shafts with no radial force

Torque distribution

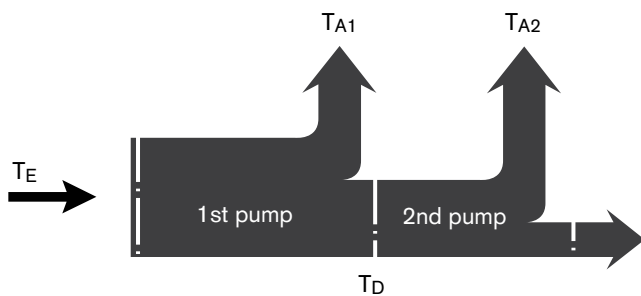

Characteristics

Drive power and flow

(Fluid: hydraulic oil ISO VG 46 DIN 51519, t = 50 °C)

Overall efficiency: $\eta_t = \frac{q_v \cdot p}{P_{qv \max} \cdot 600}$

Volumetric efficiency: $\eta_v = \frac{q_v}{q_{v \text{ theor}}}$

Size 71

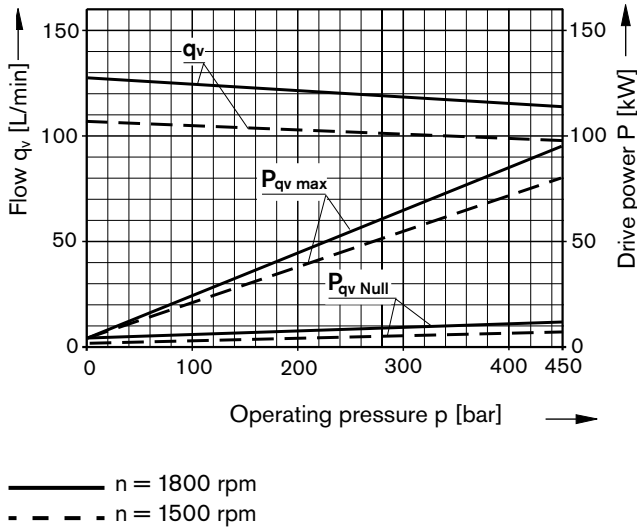

Size 125

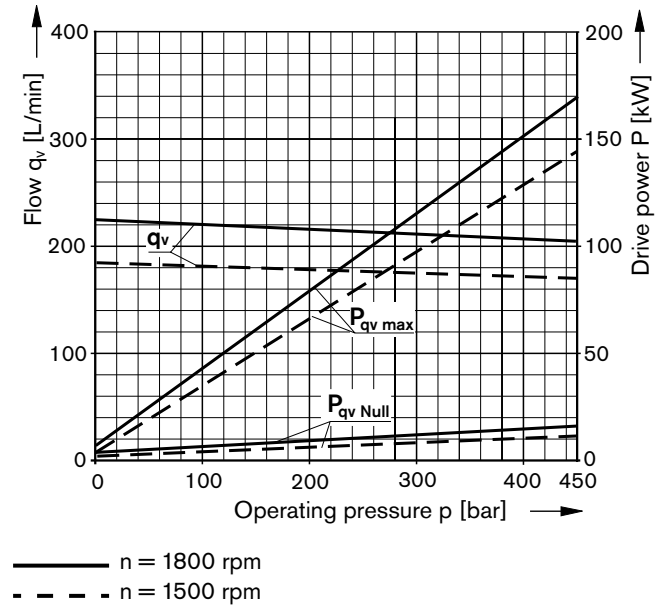

Characteristics

Drive power and flow

(Fluid: hydraulic oil ISO VG 46 DIN 51519, t = 50 °C)

Overall efficiency: $\eta_t = \frac{q_v \cdot p}{P_{qv \max} \cdot 600}$

Volumetric efficiency: $\eta_v = \frac{q_v}{q_{v \text{ theor}}}$

Size 450

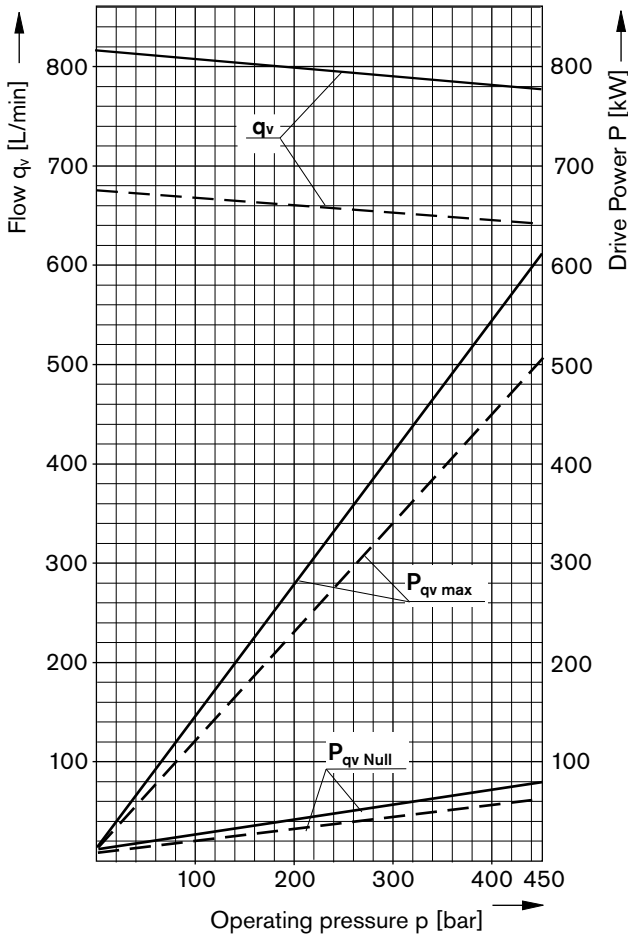

— $n = 1800$ rpm
 - - - $n = 1500$ rpm

Control devices

Control system HS4, with proportional valve (see RE 92076)

The stepless displacement adjustment is achieved with a proportional valve and an electric feedback of the swivel angle. With an external pressure signal, the HS4-control device can be completed into a pressure-power control system.

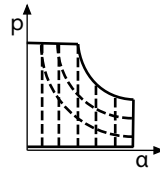

Size 71

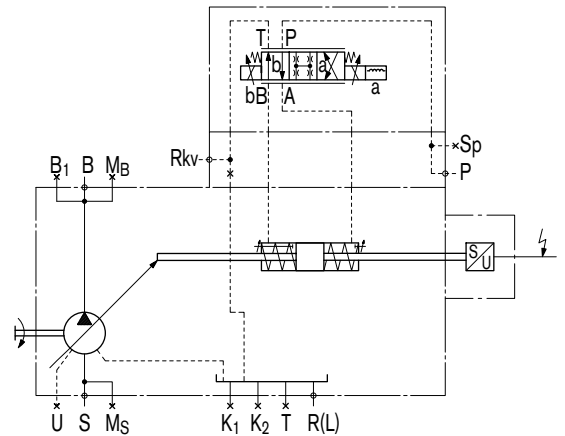

Size 125

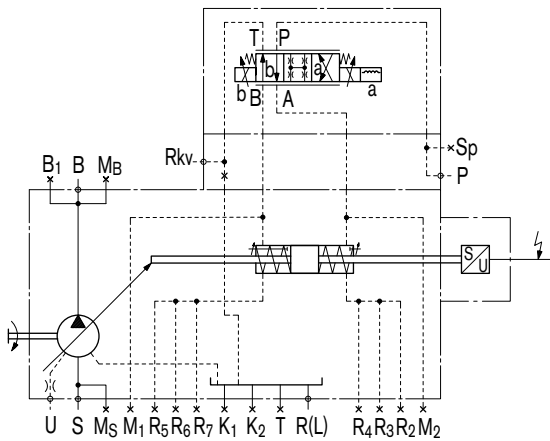

Size 450

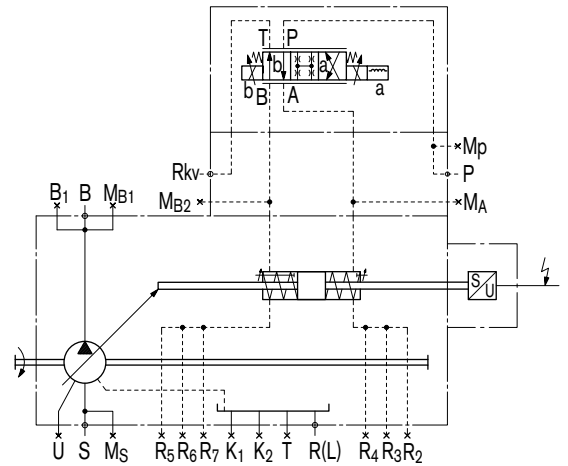

| Size | 71 | 125 | 450 |
|------------------|-----------|-----------|-----------|
| Control pressure | p_{min} | p_{min} | p_{min} |
| | bar | bar | bar |
| | p_{max} | p_{max} | p_{max} |
| | bar | bar | bar |

Control devices

Electro hydraulic control system DFE1 (see RE 92088)

The power, pressure and swivel angle control of the variable displacement pump A4VBO...DFE1 is accomplished with an electrically driven proportional valve. Through a swivel angle feedback the current signal to the proportional valve determines via the control piston the swivel angle and thus the pump displacement.

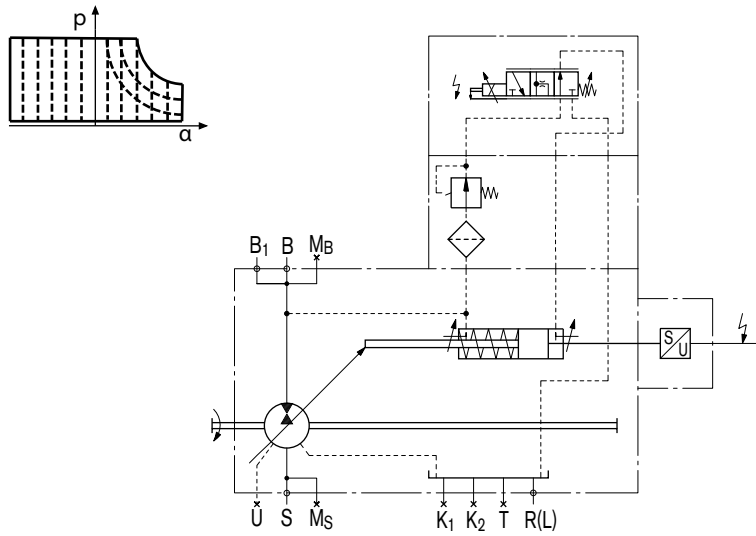

Dimensions size 71

Before finalizing your design, request a binding installation drawing. Dimensions in mm.

HS4 - hydraulic control, with proportional valve

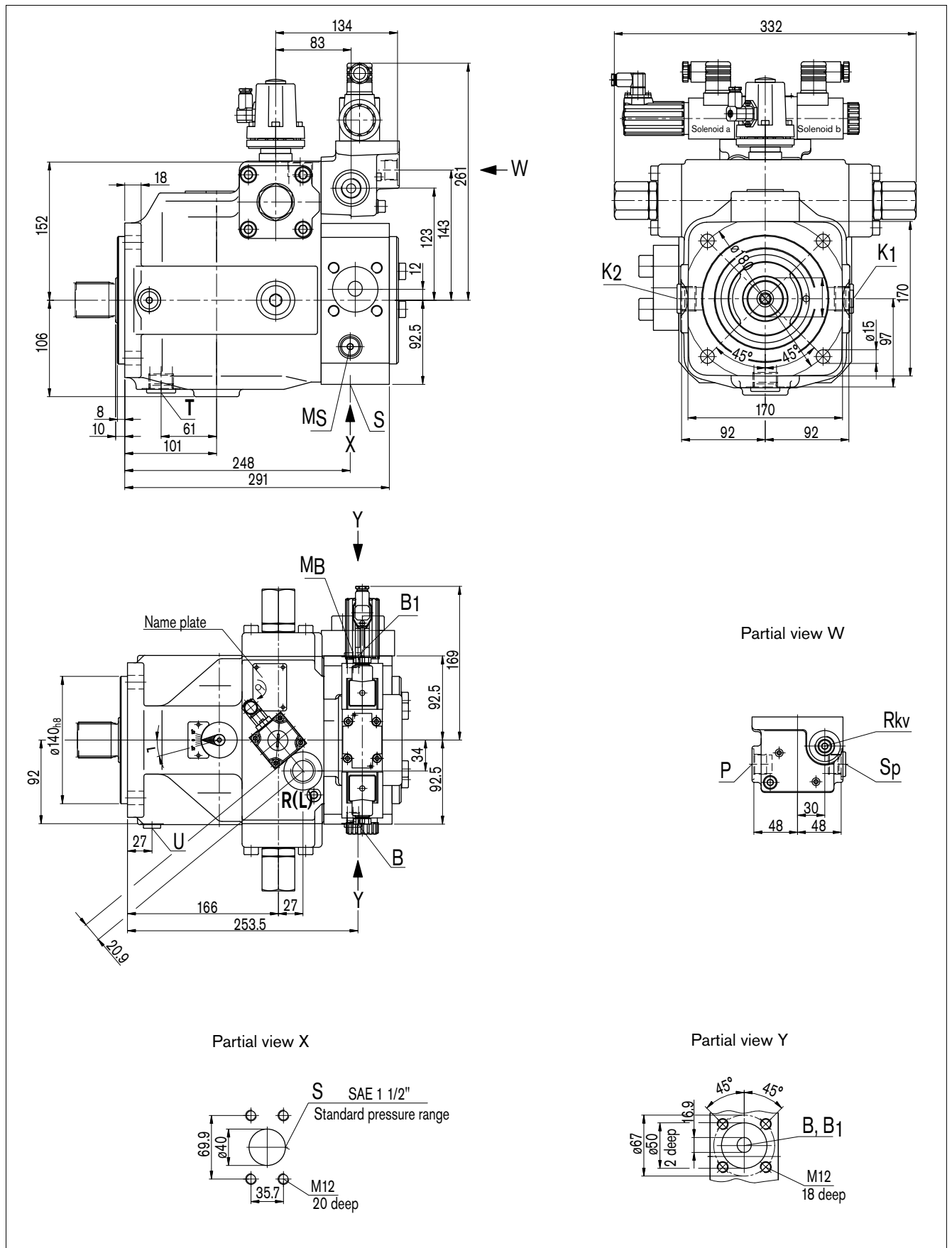

Dimensions size 71

Before finalizing your design, request a binding installation drawing. Dimensions in mm.

DFE1 - Electro hydraulic control system

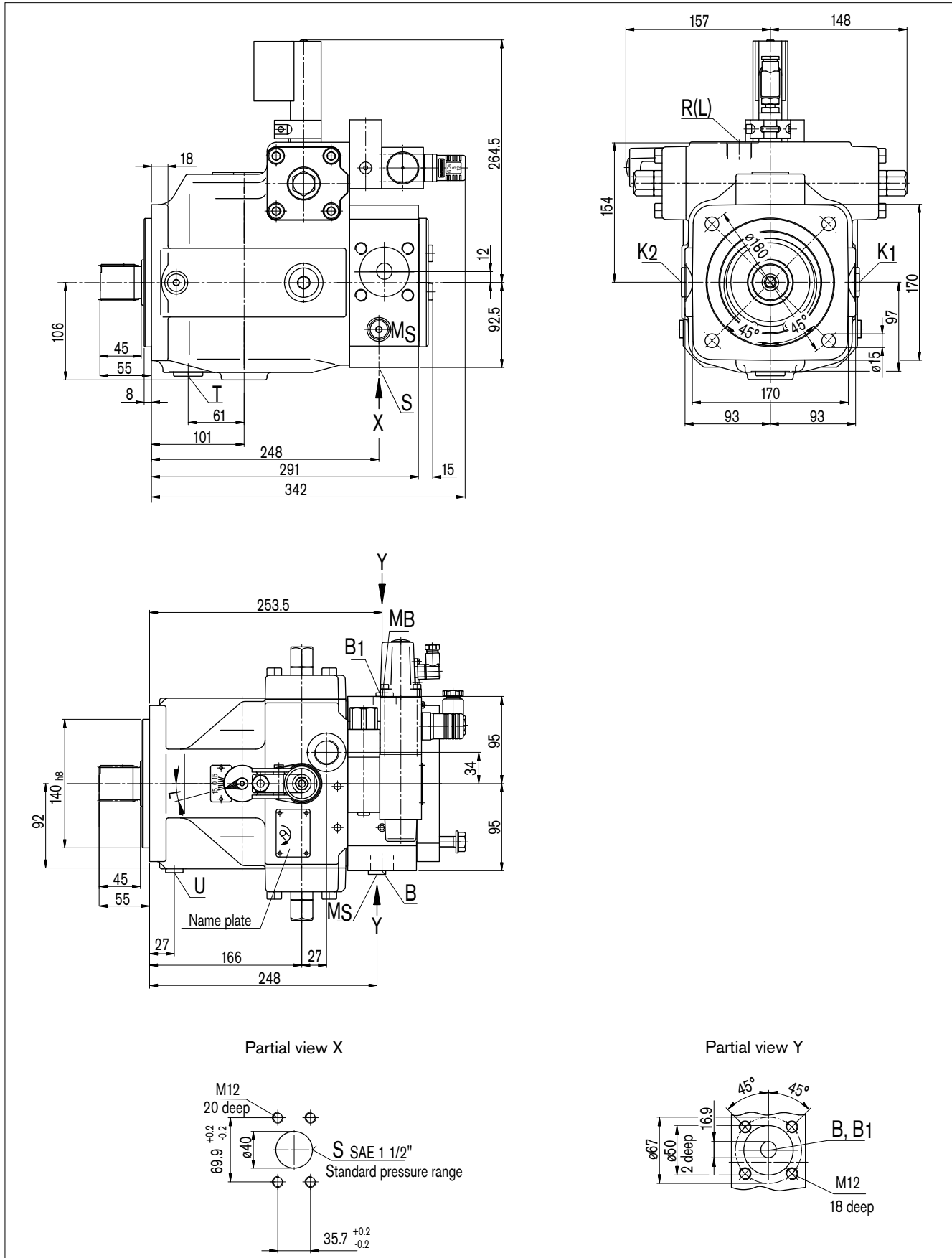

Dimensions size 71

Before finalizing your design, request a binding installation drawing. Dimensions in mm.

Drive shaft

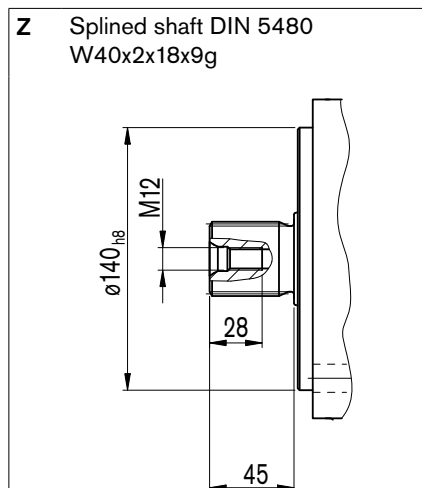

Ports

| Designation | Port for | Standard | Size ¹⁾ | Maximum pressure absolute [bar] ²⁾ | State |
|---------------------------------|---|------------------------|----------------------|---|-------|
| B | Service line | ISO/DIS 6164-3 | DN-16 | 500 | O |
| | Fixing thread B | DIN 13 | M12 x 1.75; 18 deep | | |
| B ₁ | Additional port | ISO/DIS 6164-3 | DN-16 | 500 | X |
| | Fixing thread B ₁ | DIN 13 | M12 x 1.75; 18 deep | | |
| S | Suction port | SAE J518 ³⁾ | SAE 1 1/2 in | 30 | O |
| | Fixing thread S | DIN 13 | M12 x 1.75; 20 deep | | |
| K ₁ , K ₂ | Housing flushing | ISO 6149 ⁴⁾ | M27 x 2; 19 deep | 4 | X |
| M _B | Measuring pressure B | ISO 6149 | M14 x 1.5; 11.5 deep | 500 | X |
| M _S | Measuring suction pressure | ISO 6149 | M14 x 1.5; 11.5 deep | 30 | X |
| P, Sp | Control pressure | DIN 3852 | M22 x 1.5; 15.5 deep | 315 | O |
| Rkv | Return line control fluid | DIN 3852 | M22 x 1.5; 15.5 deep | 210 | O |
| R(L) | Fluid filling and air bleed (case drain port) | ISO 6149 ⁴⁾ | M27 x 2; 19 deep | 4 | O |
| T | Fluid drain | ISO 6149 ⁴⁾ | M27 x 2; 19 deep | 4 | X |
| U | Bearing flushing | ISO 6149 ⁴⁾ | M14 x 1.5; 11.5 deep | 4 | X |

1) Observe the general instructions on page 28 for the maximum tightening torques.

2) Short-term pressure spikes may occur depending on the application. Keep this in mind when selecting measuring devices and fittings.

3) Note: metric thread deviates from standard

4) The spot face can be deeper than specified in the appropriate standard.

O = Must be connected (on delivery closed with a plastic plug or flange cover)

X = Plugged (in normal operation)

Note

The ports and fixing threads are designed for the specified maximum pressure. The machine or system manufacturer must ensure that the connecting elements and lines correspond to the specified operating conditions (pressure, flow, hydraulic fluid, temperature) with the necessary safety factors.

Dimensions size 125

Before finalizing your design, request a binding installation drawing. Dimensions in mm.

HS4 - Hydraulic control, with proportional valve, clockwise rotation

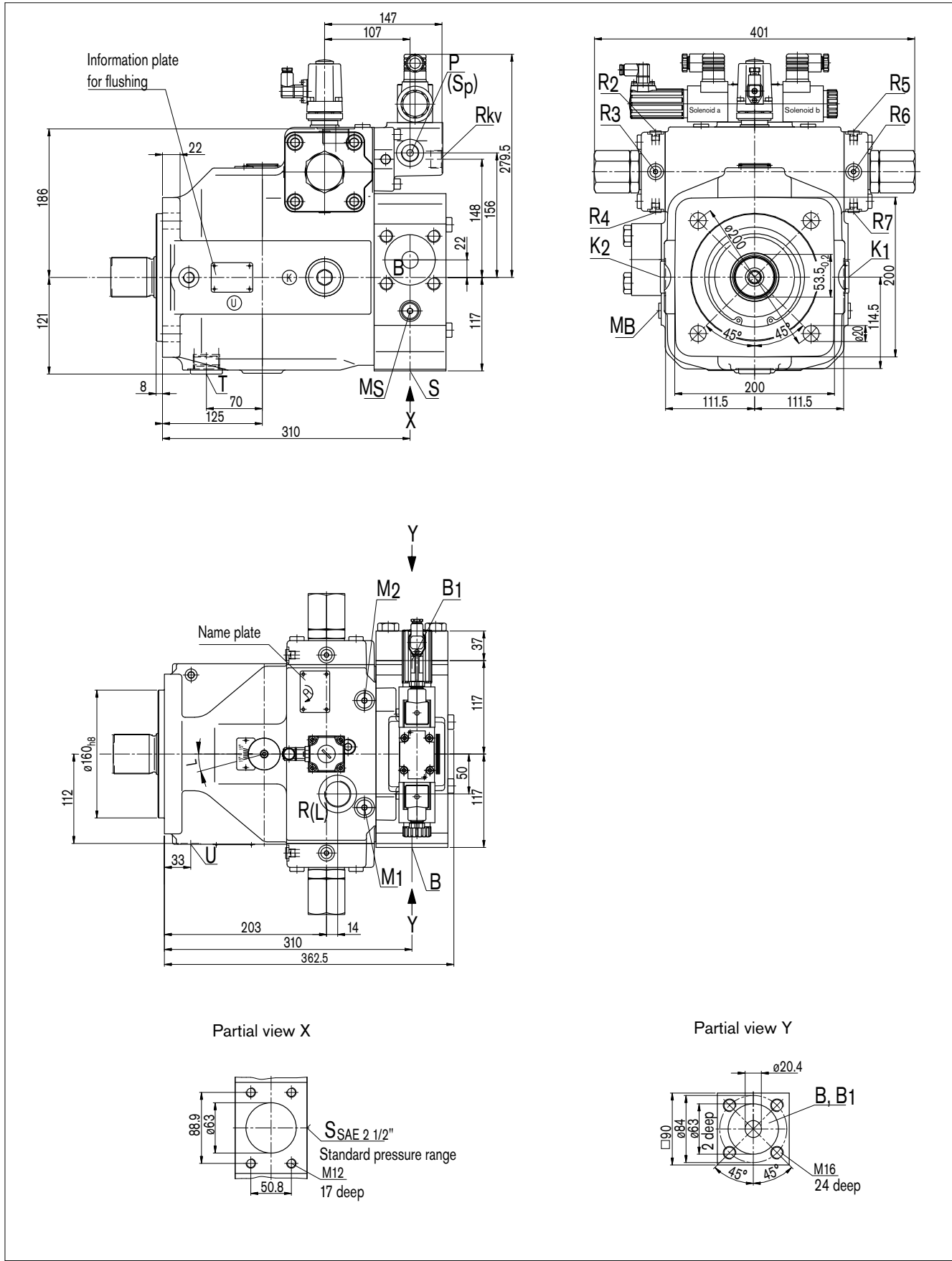

Dimensions size 125

Before finalizing your design, request a binding installation drawing. Dimensions in mm.

DFE1 - Electro hydraulic control system

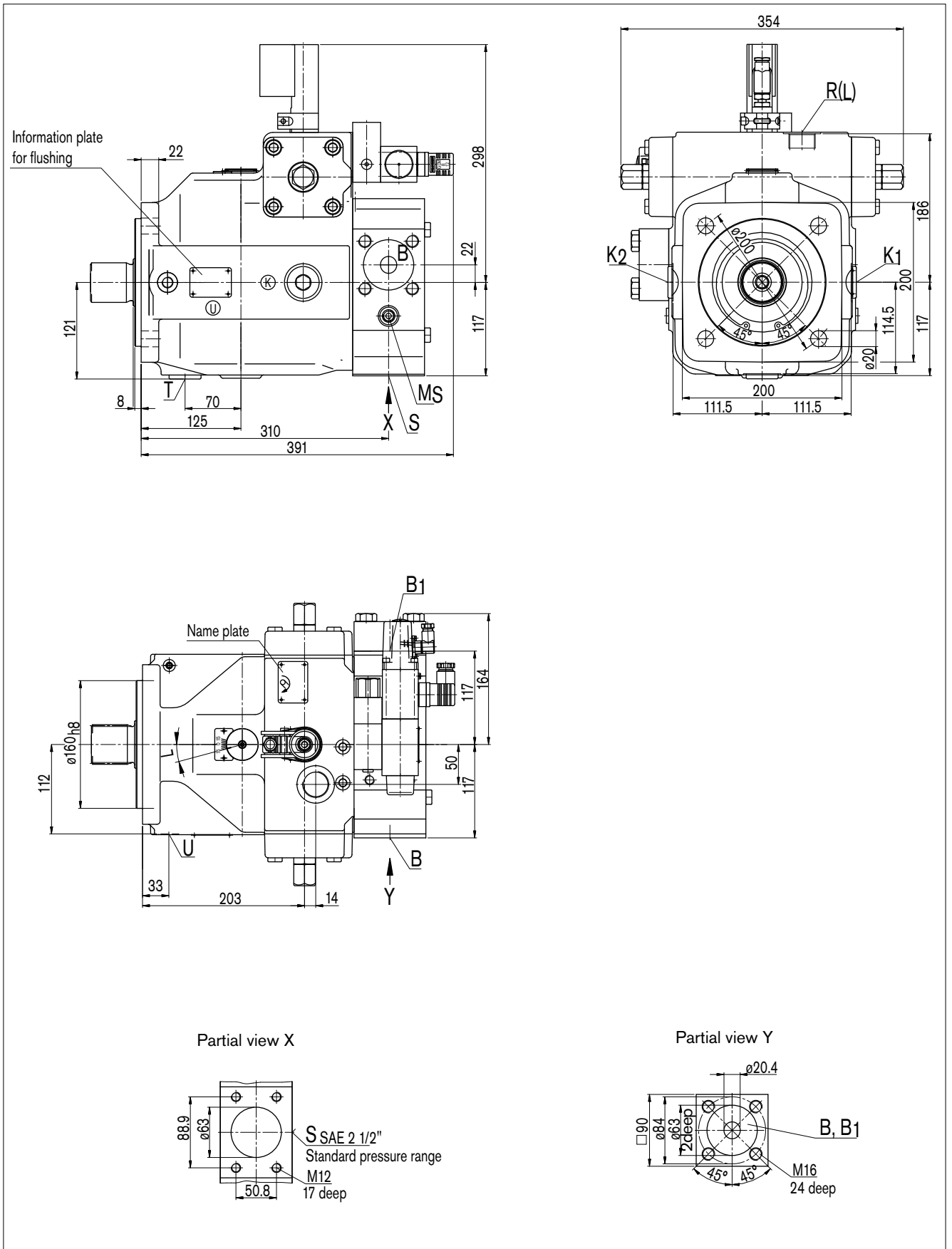

Dimensions size 125

Before finalizing your design, request a binding installation drawing. Dimensions in mm.

Drive shaft

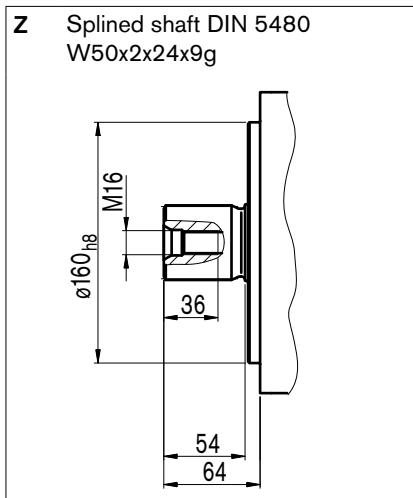

Ports

| Designation | Port for | Standard | Size ¹⁾ | Maximum pressure absolute [bar] ²⁾ | State |
|---------------------------------|---|------------------------|----------------------|---|-------|
| B | Service line | ISO/DIS 6164-3 | DN-20 | 500 | O |
| | Fixing thread B | DIN 13 | M16 x 2; 24 deep | | |
| B ₁ | Additional port | ISO/DIS 6164-3 | DN-20 | 500 | X |
| | Fixing thread B1 | DIN 13 | M16 x 2; 24 deep | | |
| S | Suction line | SAE J518 ³⁾ | SAE 2 1/2" | 30 | O |
| | Fixing thread S | DIN 13 | M12 x 1.75; 18 deep | | |
| K ₁ , K ₂ | Housing flushing | ISO 6149 ⁴⁾ | M33 x 2; 18 deep | 4 | X |
| M _B | Measuring pressure B | ISO 6149 | M14 x 1.5; 11.5 deep | 500 | X |
| M _S | Measuring suction pressure | ISO 6149 | M14 x 1.5; 11.5 deep | 30 | X |
| M ₁ , M ₂ | Measuring control pressure | ISO 6149 ⁴⁾ | M14 x 1.5; 11.5 deep | 315 | X |
| P, Sp | Control pressure | DIN 3852 | M22 x 1.5; 15.5 deep | 315 | O |
| Rkv | Return line control fluid | DIN 3852 | M22 x 1.5; 15.5 deep | 210 | O |
| R(L) | Fluid filling and air bleed (case drain port) | ISO 6149 ⁴⁾ | M33 x 2; 18 deep | 4 | O |
| R ₂ -R ₇ | Air bleed control unit | DIN 3852 | M10 x 1; 10 deep | 315 | X |
| T | Fluid drain | ISO 6149 ⁴⁾ | M33 x 2; 18 deep | 4 | X |
| U | Bearing flushing | ISO 6149 ⁴⁾ | M14 x 1.5; 11.5 deep | 7 | X |

1) Observe the general instructions on page 28 for the maximum tightening torques.

2) Short-term pressure spikes may occur depending on the application. Keep this in mind when selecting measuring devices and fittings.

3) Note: metric thread deviates from standard

4) The spot face can be deeper than specified in the appropriate standard.

O = Must be connected (on delivery closed with a plastic plug or flange cover)

X = Plugged (in normal operation)

Note

The ports and fixing threads are designed for the specified maximum pressure. The machine or system manufacturer must ensure that the connecting elements and lines correspond to the specified operating conditions (pressure, flow, hydraulic fluid, temperature) with the necessary safety factors.

Dimensions size 450

Before finalizing your design, request a binding installation drawing. Dimensions in mm.

Drive shaft

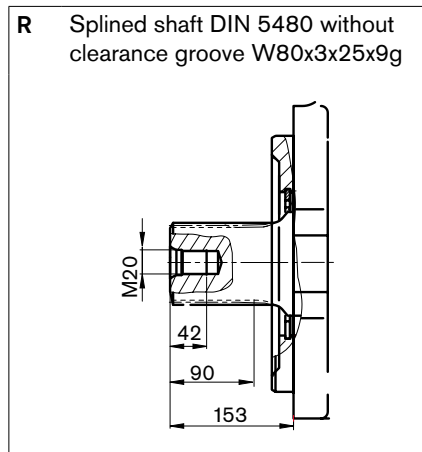

Ports

| Designation | Port for | Standard | Size ¹⁾ | Maximum pressure absolute [bar] ²⁾ | State |
|---|---|------------------------|----------------------|---|-------|
| B | Service line | ISO/DIS 6164-3 | DN-50 | 500 | O |
| | Fixing thread B | DIN 13 | M30 x 3.5; 45 deep | | |
| B ₁ | Additional port | ISO/DIS 6164-3 | DN-50 | 500 | X |
| | Fixing thread B1 | DIN 13 | M30 x 3.5; 45 deep | | |
| S | Suction | SAE J518 ³⁾ | SAE 5 in | 30 | O |
| | Fixing thread S | DIN 13 | M16 x 2; 24 deep | | |
| K ₁ , K ₂ | Housing flushing | DIN 3852 | M48 x 2; 22 deep | 4 | X |
| M _{B1} | Measuring pressure B1 | ISO 6149 | M18 x 1.5; 14.5 deep | 500 | X |
| M _S | Measuring suction pressure | ISO 6149 | M18 x 1.5; 14.5 deep | 30 | X |
| M _A , M _{B2} , M _P | Measuring control pressure | DIN 3852 | M14 x 1.5; 11.5 deep | 315 | X |
| P | Control pressure | DIN 3852 | M27 x 2; 19 deep | 315 | X |
| Rkv | Return line control fluid | DIN 3852 | M27 x 2; 19 deep | 210 | O |
| R (L) | Fluid filling and air bleed (case drain port) | DIN 3852 | M48 x 2; 22 deep | 4 | O |
| R ₂ -R ₇ | Air bleed control device | DIN 3852 | M14 x 1.5; 11.5 deep | 315 | X |
| T | Fluid drain | DIN 3852 | M48 x 2; 22 deep | 4 | X |
| U | Bearing flushing | ISO 6149 ⁴⁾ | M18 x 1.5; 14.5 deep | 8 | X |

1) Observe the general instructions on page 28 for the maximum tightening torques.

2) Short-term pressure spikes may occur depending on the application. Keep this in mind when selecting measuring devices and fittings.

3) Note: metric thread deviates from standard

4) The spot face can be deeper than specified in the appropriate standard.

O = Must be connected (on delivery closed with a plastic plug or flange cover)

X = Plugged (in normal operation)

Note

The ports and fixing threads are designed for the specified maximum pressure. The machine or system manufacturer must ensure that the connecting elements and lines correspond to the specified operating conditions (pressure, flow, hydraulic fluid, temperature) with the necessary safety factors.

Overview of attachments

| Through drive - A4VBO | | | Mounting option 2nd pump | | | | | | Through drive |
|------------------------------|-----------------------------------|------------|--------------------------|-----------------|-----------------|-----------------------------------|--------------------|------------------------------------|-----------------------|
| Flange | Coupler for splined shaft | Code | A4VBO | A4VSO/G | A4CSG | A10V(S) O/31 (2) ¹⁾ | A10V(S) O/52(3) | External/ internal gear pump | Available for size |
| | | | size (shaft) | size (shaft) | size (shaft) | size (shaft) | size (shaft) | | |
| ISO 3019-2 (metric) | | | | | | | | | |
| 140, 4-bolt | W 40x2x18x9g ³⁾ | K33 | 71 (Z) | 71 (Z) | – | – | – | – | 71/In preparation |
| 160, 4-bolt | W 50x2x24x9g ³⁾ | K34 | 125 (Z) | 125 (Z) | – | – | – | – | In preparation |
| | | | – | 180 (Z) | – | – | – | – | In preparation |
| 315, 8-bolt | W 80x3x25x9g ³⁾ | K97 | 450 (R) | – | – | – | – | – | 450 |
| ISO 3019-1 (SAE J744) | | | | | | | | | |
| 82-2 (A) ⁴⁾ | 16-4 (5/8in, 9T) ²⁾ | K01 | – | – | – | – | – | AZ-PF-1X-004...022 ⁵⁾ | In preparation |
| 101-2 (B) ⁴⁾ | 22-4 (7/8in, 13T) ²⁾ | K68 | – | – | – | 28 (S)/31 | 28 (S) | AZ-PN-1X-020...032 ⁵⁾ | 71/In preparation |
| | 25-4 (1in, 15T) ²⁾ | K04 | – | – | – | 45 (S)/31 | 45 (S) | PGH4 | In preparation |
| 127-2 (C) ⁴⁾ | 38-4 (1 1/2in, 17T) ²⁾ | K24 | – | – | – | 100 (S)/31 | 85 (S) | PGH5 | In preparation |

1) If a through drive for an A10V(S)O with R-shaft is desired, please consult us.

2) Allocation of drive shafts to SAEJ744 OCT83

3) Acc. to DIN 5480

4) 2 = 2-bolt, 4 = 4-bolt

5) Rexroth recommends a special execution of the gear pumps. Please consult us.

Through drive dimensions

Before finalizing your design, request a binding installation drawing. Dimensions in mm.

K33 Size 71

Flange ISO 3019-2 140, 4-bolt

Shaft coupler to DIN 5480 N40x2x18x8H

for mounting an A4VSO/G 71 with splined shaft

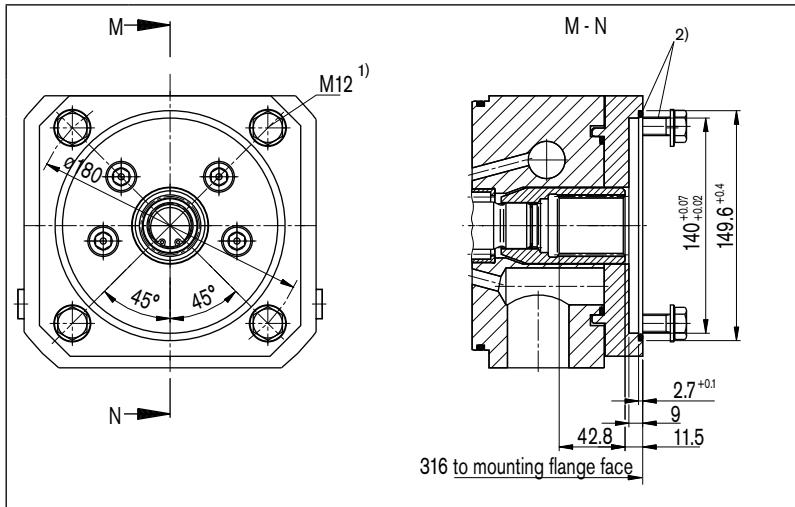

K34 Size 125 and 450

Flange ISO 3019-2 160, 4-bolt

Shaft coupler to DIN 5480 N50x2x24x8H

for mounting an A4VSO/G 125 or 180 with splined shaft

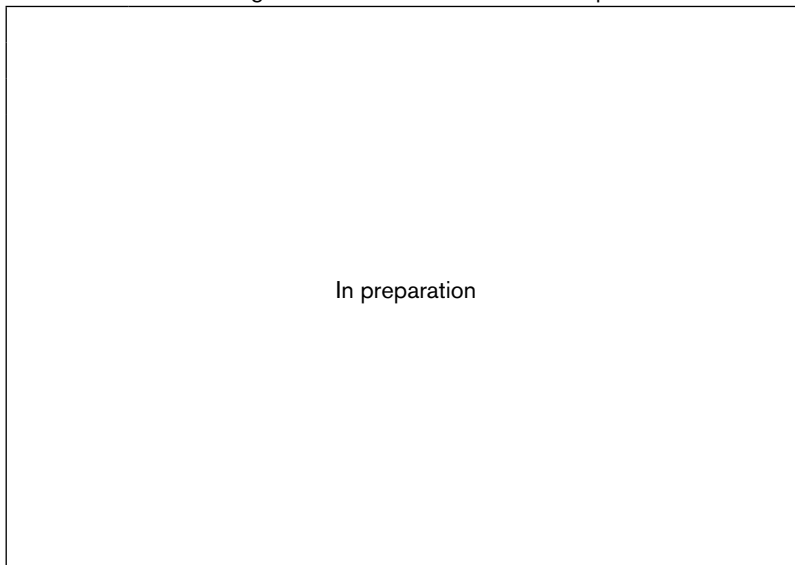

1) Thread according to DIN 13, observe the general instructions on page 28 for the maximum tightening torques.

2) Fixing screws and O-ring seal are included with supply.

Through drive dimensions

Before finalizing your design, request a binding installation drawing. Dimensions in mm.

K97 Size 450
 Flange ISO 3019-2 315-8-bolt
 Shaft coupler to DIN 5480 N80x3x25x8H

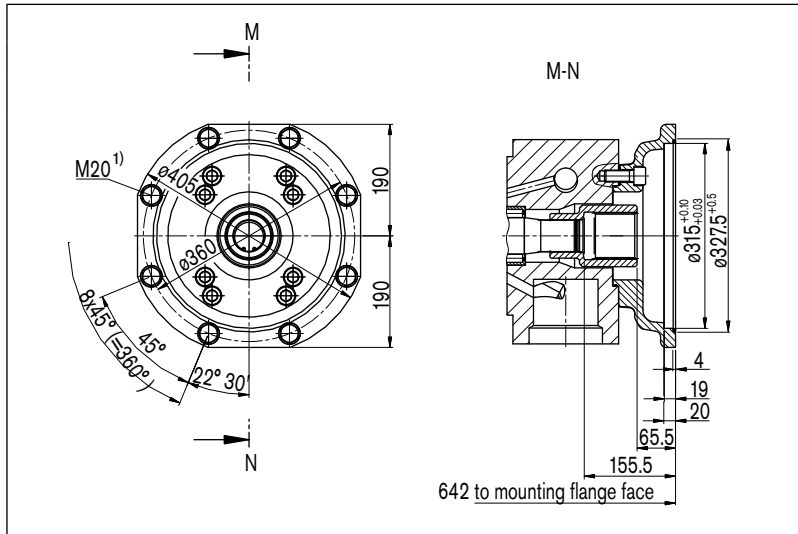

K99 Size 71
 with through drive shaft, without shaft coupler, without adaptor flange, closed with pressure tight cover

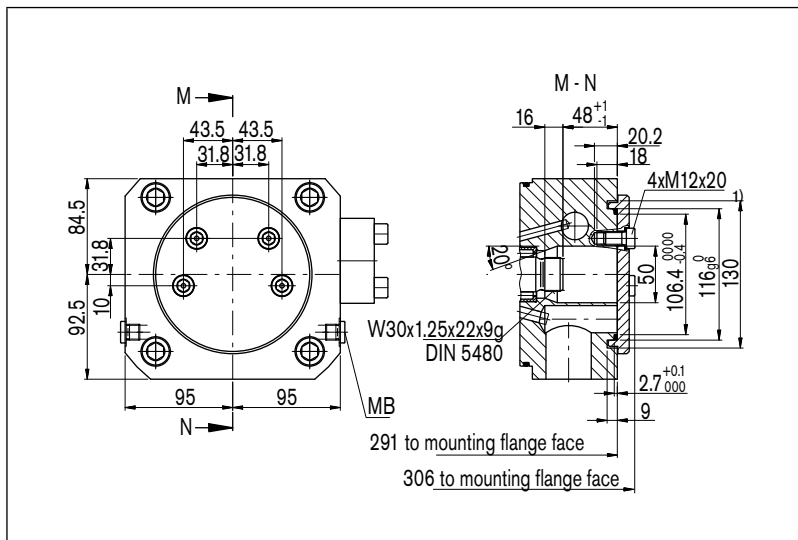

¹⁾ Thread according to DIN 13, observe the general instructions on page 28 for the maximum tightening torques

Through drive dimensions

Before finalizing your design, request a binding installation drawing. Dimensions in mm.

K99 Size 125

with through drive shaft, without shaft coupler, without adaptor flange, closed with pressure tight cover (shown without cover)

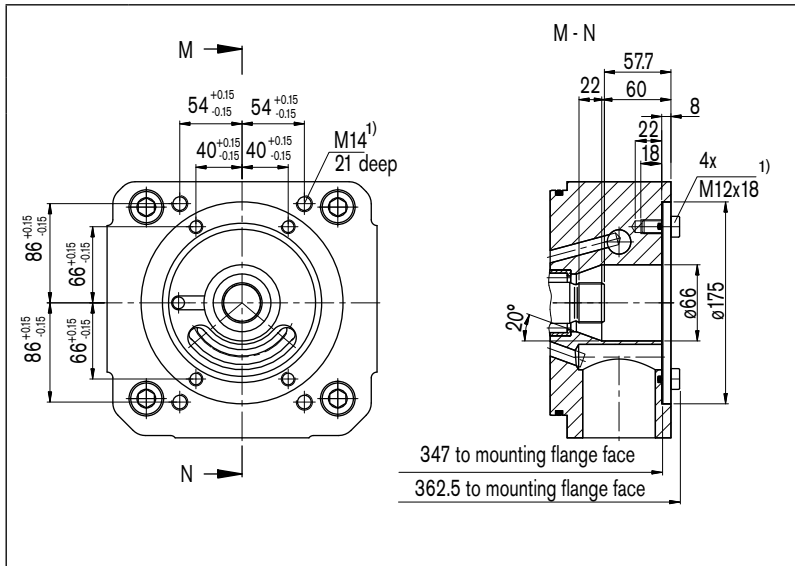

K99 Size 450

with through drive shaft, without shaft coupler, without adaptor flange, closed with pressure tight cover

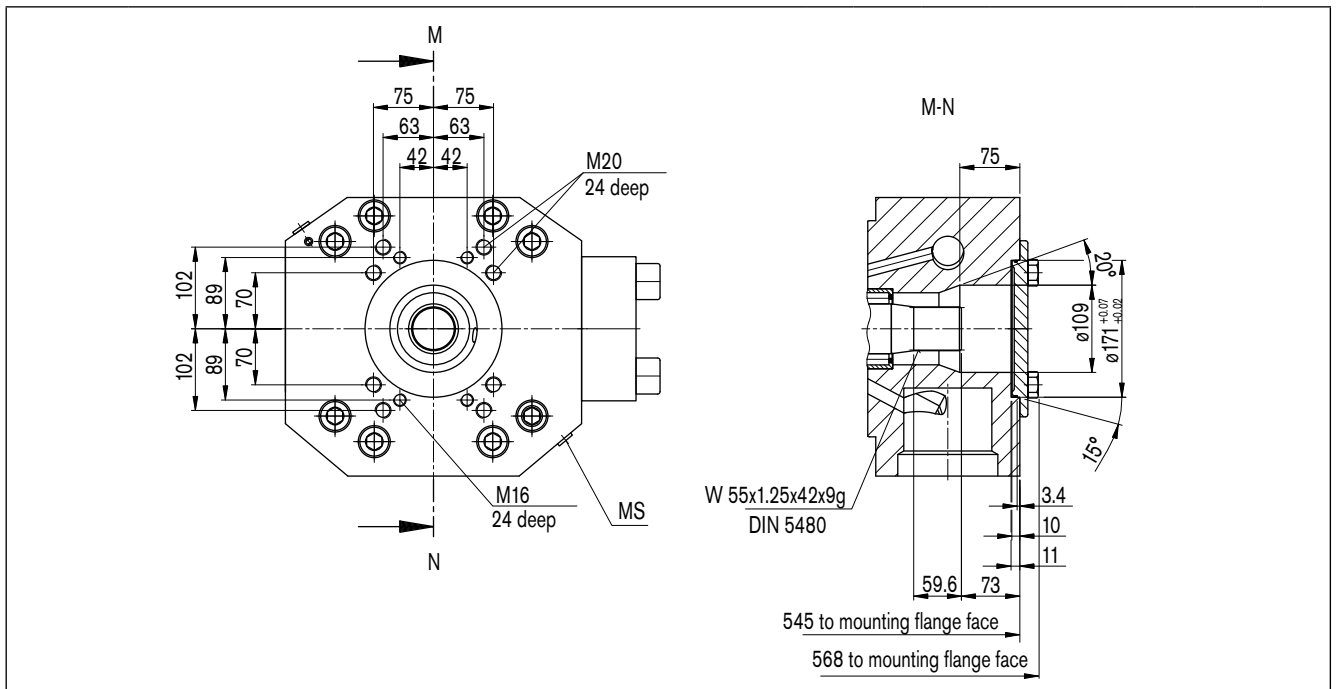

¹⁾ Thread according to DIN 13, observe the general instructions on page 28 for the maximum tightening torques

Installation instructions

Mounting position:

Optional. The pump case must be filled with fluid during commissioning and remain full when operating. In order to reduce the operating noise level, all connecting lines (suction, pressure and case drain lines) must be de-coupled from the tank, using flexible elements. The use of check valves in the case drain line must be avoided. The case drain line must be returned directly to tank without a reduction in cross section. Exceptions maybe possible, please consult us first.

1. Vertical installation (shaft end pointing upwards)
 With a vertical installation, bearing flushing is recommended to provide lubrication for the front bearing, see page 5.

The following installation conditions must be taken into account:

1.1 Installation into the reservoir

a) When the minimum fluid level is equal to or above the pump mounting flange area (**only possible for the sizes 71 and 125**): ports »R/L«, »T« and »S« open (see fig. 1).

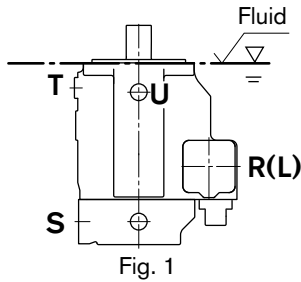

b) When the minimum fluid level is below the mounting flange area: ports »R/L«, »T« and possibly »S« must be piped as shown in fig. 2. Also observe the conditions as shown in point 1.2.

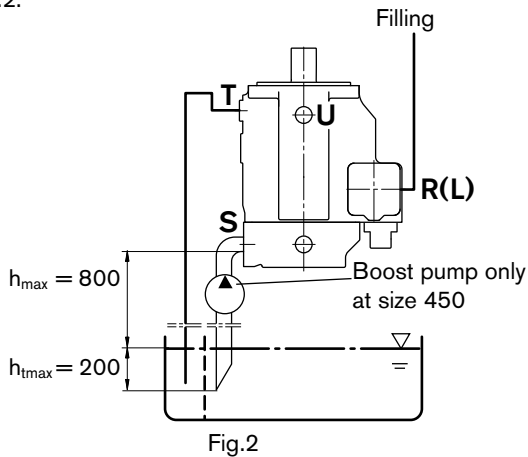

1.2 Installation outside the reservoir

Before installation, fill the pump housing with the pump in a horizontal position. Pipe port »T« to tank, »R/L« plugged. Filling in mounted condition: fill via »R« and bleed via »T«, afterwards plug port »R«.

Conditions: A minimum pump inlet pressure (suction pressure) of 0.8 bar absolute for size 71/125 is necessary (of 5 bar absolute for size 450). Avoid mounting above the reservoir in order to reduce the noise level.

2. Horizontal installation

The highest situated of the ports »T«, »K₁«, »K₂« or »R/L« must be used for filling/bleeding and subsequently to connect the case drain line.

2.1 Installation inside the reservoir

a) When the minimum fluid level is equal to or lies above the upper edge of the pump (only possible for sizes 71 and 125): case drain port and suction port »S« open (see fig. 3).

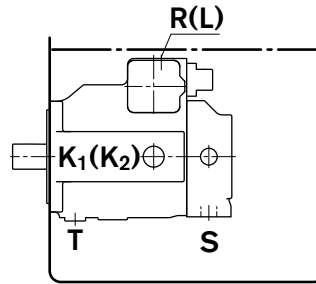

Fig. 3

b) When the minimum fluid level lies below the upper edge of the pump: case drain port and possibly port »S« must be piped, see fig. 4. Observe conditions as shown in point 1.2.

Fill pump housing prior to commissioning.

2.2 Installation outside the reservoir

Fill the pump housing before commissioning.

a) Mounting above the reservoir see fig. 4.

Observe conditions as shown in point 1.2.

b) Mounting below the reservoir

Case drain port and port »S« must be piped (see fig. 5).

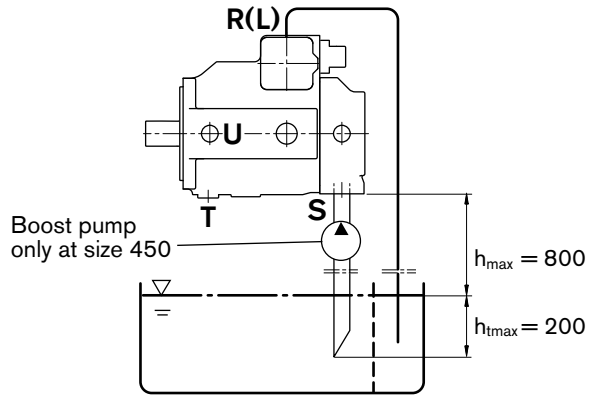

Fig. 4

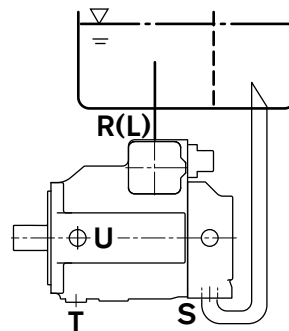

Fig. 5

Notes

General instructions

- The A4VBO pump is designed to be used in open circuit.
- Project planning, assembly and commissioning of the axial piston unit require the involvement of qualified personnel.
- Before operating the axial piston unit, read the appropriate operating instructions thoroughly and completely. If needed, request these from Rexroth.
- The service line ports and function ports are only designed to accommodate hydraulic lines.
- During and shortly after operation, there is a risk of burns on the axial piston unit and especially on the solenoids. Take appropriate safety measures (e. g. by wearing protective clothing).
- Depending on the operating conditions of the axial piston unit (operating pressure, fluid temperature), the characteristics may shift.
- Pressure ports:
The ports and fixing threads are designed for the specified maximum pressure. The machine or system manufacturer must ensure that the connecting elements and lines correspond to the specified operating conditions (pressure, flow, hydraulic fluid, temperature) with the necessary safety factors.
- The data and notes contained herein must be adhered to.
- The following tightening torques apply:
 - Female threads in axial piston unit:
The maximum permissible tightening torques $M_{G \max}$ are maximum values for the female threads and must not be exceeded. For values, see the following table.
 - Fittings:
Observe the manufacturer's instructions regarding the tightening torques of the used fittings.
 - Fixing screws:
For fixing screws according to DIN 13, we recommend checking the tightening torque individually according to VDI 2230.
 - Locking screws:
For the metal locking screws, supplied with the axial piston unit, the required tightening torques of locking screws M_V apply. For values, see the following table.
- The product is not approved as a component for the safety concept of a general machine according to DIN EN ISO 13849.

| Ports | | Maximum permissible tightening torque of the threaded holes $M_{G \max}$ | Required tightening torque of the locking screws M_V | WAF hexagon socket of the locking screws |
|----------|-------------|--|--|--|
| Standard | Thread size | | | |
| ISO 6149 | M14 x 1.5 | 80 Nm | 45 Nm | 6 mm |
| | M18 x 1.5 | 140 Nm | 70 Nm | 8 mm |
| | M27 x 2 | 330 Nm | 170 Nm | 12 mm |
| | M33 x 2 | 540 Nm | 310 Nm | 17 mm |
| DIN 3852 | M10 x 1 | 30 Nm | 15 Nm ¹⁾²⁾ | 5 mm |
| | M14 x 1.5 | 80 Nm | 35 Nm ¹⁾ | 6 mm |
| | M22 x 1.5 | 210 Nm | 80 Nm ¹⁾ | 10 mm |
| | M27 x 2 | 330 Nm | 135 Nm ¹⁾ | 12 mm |
| | M48 x 2 | 900 Nm | 400 Nm ¹⁾ | 24 mm |

1) The tightening torques apply for screws in the „dry“ state as received on delivery and the „lightly oiled“ state for installation.

2) In the „lightly oiled“ state, the M_V is reduced to 10 Nm for M10 x 1.