

Proportional Electro-Hydraulic Pilot Relief Valves

The valve can be used as a pilot valve of the Proportional Electro-Hydraulic Control Valves.

The valve can also be used as a relief valve for the hydraulic system where a small flow rate and continuous pressure control are required.

Specifications

Model Numbers	EHDG-01 *
Description	EHDG-01 *
Max. Operating Pres.	24.5 MPa (3550 PSI)
Max. Flow	2 L/min (.53 U.S.GPM)
Min. Flow	0.3 L/min (.08 U.S.GPM)
Pressure Adjustment Range	Refer to Model Number Designation
Coil Resistance	10 Ω
Hysteresis	3% (1%) * ¹ or less
Repeatability	1% * ² or less
Frequency Response	B: 10 (27) Hz * ¹ C: 10 (27) Hz * ¹ (-90 degree) H: 12 (27) Hz * ¹
Supply Electric Power	24 V DC (21 to 28 V DC Included Ripple)
Power Input (Max.)	28 W
Input Signal	B: 6.9 MPa (1000 PSI) / 5 V DC C: 15.7 MPa (2275 PSI) / 5 V DC H: 24.5 MPa (3550 PSI) / 5 V DC
Input Impedance	10 kΩ
Alarm Signal Output (Open Collector)	Voltage: Max. 30 V DC Current: Max. 40 mA
Pressure Signal Output	B: 5 V DC / 6.9 MPa (1000 PSI) C: 5 V DC / 15.7 MPa (2275 PSI) H: 5 V DC / 24.5 MPa (3550 PSI)
Ambient Temperature	0 - 50°C (32 - 122°F) (With Circulated Air)

★1. The value in () is for the closed-loop type.

★2. The repeatability of the valve is obtained by having it tested independently on the conditions similar to its original testing.

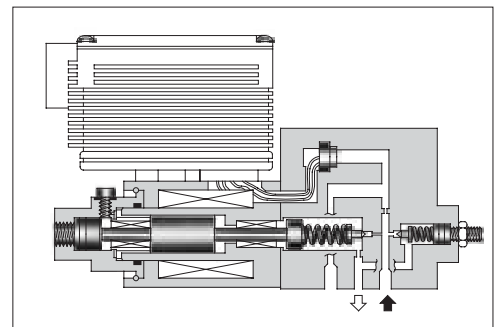

Graphic Symbols

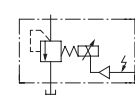

Open-Loop Type

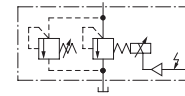

Open-Loop Type with Safety Valve

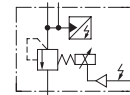

Open-Loop Type with Sensor

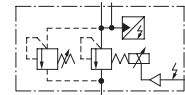

Open-Loop Type with Safety Valve & Sensor

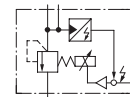

Closed-Loop Type

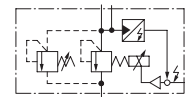

Closed-Loop Type with Safety Valve

Model Number Designation

F-	EHD	G	-01	V	-B	-S	-1	-PN	T15	M10	-50
Special Seals	Series Number	Type of Mounting	Valve Size	Applicable Control	Pres. Adj. Range MPa (PSI)	Control Type	Safety Valve	P-Line Orifice	T-Line Orifice	P-B Line Orifice	Design Number
F: Special Seals for Phosphate Ester Type Fluid (Omit if not required)	EHD: Proportional Electro-Hydraulic Pilot Relief Valve	G: Sub-plate Mounting	01	None: For general use V: Vent Control of Relief Valve (Omit if not required)	B: 0.5 - 6.9 (70 - 1000) C: 1 - 15.7 (145 - 2275) H: 1.2 - 24.5 (175 - 3550)	None: Open-Loop S: Open-Loop with Sensor L: Closed-Loop★1	None: Without Safety Valve 1: With Safety Valve	PN: Without Orifice (Standard)	T15 T13 T11 ★2	M10: Standard Orifice	50

★1. For closed-loop models, specify applicable control code "V" even though the valve may not be used as vent control of relief valve.

★2. Standard of T-line Orifice.
Pres. Adj. Range B:T15, C:T13, H:T11.