

final pump - series XV

SHAPED FINAL PUMP
SHAPED FEMALE $\varnothing 25,4$ FLANGE

X1F-1

X 1 F 25 74 T I I A

Series	X	series XV
Group	1	group 1
Category	F	final pump
Displacement	25	3.8
Flange	74	$\varnothing 25.4$ body-shaped female right rotation 1P+0P
Shaft	T	SCF01 - Final
Body	IN	inlet - $\varnothing 30 \varnothing 12$ M6
	OUT	outlet - $\varnothing 30 \varnothing 12$ M6
Cover	A	standard

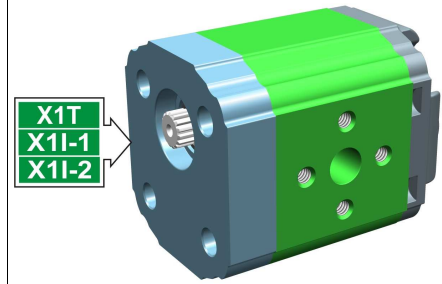

XF102

Technical data table

TYPE	Displacement cm ³ /rev	Max. Pressure		CODE																	
		P1 bar	P3 bar	Left rotation			Right rotation														
X1F-1/0.9	0,91	240	280	X	1	F	16	73	T	I	I	A	X	1	F	16	74	T	I	I	A
X1F-1/1.2	1,17	250	290	X	1	F	17	73	T	I	I	A	X	1	F	17	74	T	I	I	A
X1F-1/1.7	1,56	250	290	X	1	F	18	73	T	I	I	A	X	1	F	18	74	T	I	I	A
X1F-1/2.2	2,08	250	290	X	1	F	20	73	T	I	I	A	X	1	F	20	74	T	I	I	A
X1F-1/2.6	2,60	250	300	X	1	F	21	73	T	I	I	A	X	1	F	21	74	T	I	I	A
X1F-1/3.2	3,12	250	300	X	1	F	23	73	T	I	I	A	X	1	F	23	74	T	I	I	A
X1F-1/3.8	3,64	250	300	X	1	F	25	73	T	I	I	A	X	1	F	25	74	T	I	I	A
X1F-1/4.3	4,16	250	300	X	1	F	27	73	T	I	I	A	X	1	F	27	74	T	I	I	A
X1F-1/4.9	4,94	250	300	X	1	F	29	73	T	I	I	A	X	1	F	29	74	T	I	I	A
X1F-1/5.9	5,85	250	300	X	1	F	31	73	T	I	I	A	X	1	F	31	74	T	I	I	A
X1F-1/6.5	6,50	250	300	X	1	F	32	73	T	I	I	A	X	1	F	32	74	T	I	I	A
X1F-1/7.8	7,54	220	260	X	1	F	34	73	T	I	I	A	X	1	F	34	74	T	I	I	A
X1F-1/9.8	9,88	190	230	X	1	F	36	73	T	I	I	A	X	1	F	36	74	T	I	I	A

P1) Max. working pressure - P3) Max. peak pressure

For heavy-duty applications, it is recommended to check the admissible torque of the shaft

Dimensions table

TYPE	Weight kg	A	B	D	E	F	D	E	F
		mm	mm	IN			OUT		
X1F-1/0.9	0,950	78,0	37,3	$\varnothing 12$	30	M6x1	$\varnothing 12$	30	M6x1
X1F-1/1.2	0,970	79,0	37,8	$\varnothing 12$	30	M6x1	$\varnothing 12$	30	M6x1
X1F-1/1.7	1,010	80,5	38,5	$\varnothing 12$	30	M6x1	$\varnothing 12$	30	M6x1
X1F-1/2.2	1,030	82,5	39,5	$\varnothing 12$	30	M6x1	$\varnothing 12$	30	M6x1
X1F-1/2.6	1,060	84,5	40,5	$\varnothing 12$	30	M6x1	$\varnothing 12$	30	M6x1
X1F-1/3.2	1,090	86,5	41,5	$\varnothing 12$	30	M6x1	$\varnothing 12$	30	M6x1
X1F-1/3.8	1,120	88,5	42,5	$\varnothing 12$	30	M6x1	$\varnothing 12$	30	M6x1
X1F-1/4.3	1,170	90,5	43,5	$\varnothing 12$	30	M6x1	$\varnothing 12$	30	M6x1
X1F-1/4.9	1,200	93,5	45,0	$\varnothing 12$	30	M6x1	$\varnothing 12$	30	M6x1
X1F-1/5.9	1,260	97,0	46,8	$\varnothing 12$	30	M6x1	$\varnothing 12$	30	M6x1
X1F-1/6.5	1,300	99,5	48,0	$\varnothing 12$	30	M6x1	$\varnothing 12$	30	M6x1
X1F-1/7.8	1,360	103,5	50,0	$\varnothing 12$	30	M6x1	$\varnothing 12$	30	M6x1
X1F-1/9.8	1,500	112,5	54,5	$\varnothing 12$	30	M6x1	$\varnothing 12$	30	M6x1

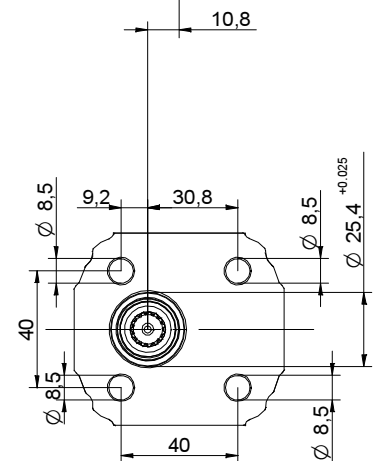
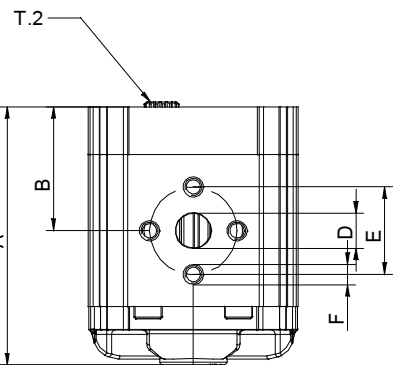
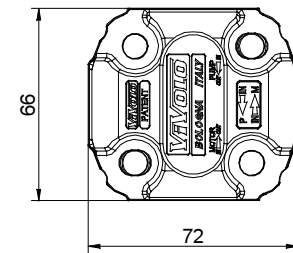

29/04/08 XF2574TIIA.dft



T.2 = 42.8 [Nm] - admissible shaft torque (N.B. When choosing a shaft, always check the admissible torque).

Table of variations

X1F-1

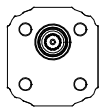
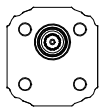
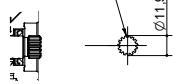
Shaped female $\varnothing 25,4$ FLANGE

Shaped female $\varnothing 25,4$ FLANGE		Shaft	
Left rotation	Right rotation		
	73		74
		SCF01 - Splined T.2 = 42.8 [Nm] m=0,75 Z=15	T
			

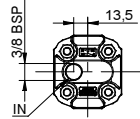
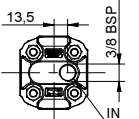
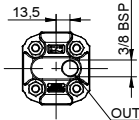
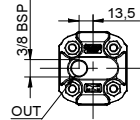
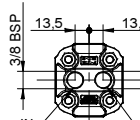
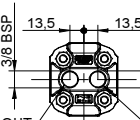
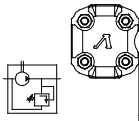
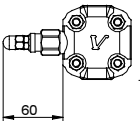
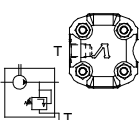
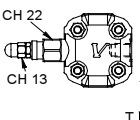
Cover		
Left rotation	Right rotation	
		A
		B
		C
		D
		N
Internal drainage		
		O
External drainage		

Displacement	
TYPE	CODE
X1F-1/0.9	16
X1F-1/1.2	17
X1F-1/1.7	18
X1F-1/2.2	20
X1F-1/2.6	21
X1F-1/3.2	23
X1F-1/3.8	25
X1F-1/4.3	27
X1F-1/4.9	29
X1F-1/5.9	31
X1F-1/6.5	32
X1F-1/7.8	34
X1F-1/9.8	36

Standard bodies							
Displacement cm3/rev	Standard threads						
	0.9	I - I	B - B	J - J	B - Z	Z - Z	G - F
1.2	I - I	B - B	J - J	B - Z	Z - Z	G - F	
1.7	I - I	B - B	J - J	B - Z	Z - Z	G - F	
2.2	I - I	B - B	J - J	B - Z	Z - Z	G - F	
2.6	I - I	B - B	J - J	B - Z	Z - Z	G - F	
3.2	I - I	B - B	J - J	B - Z	Z - Z	G - F	
3.8	I - I	B - B	J - J	B - Z	Z - Z	G - F	
4.3	I - I	B - B	J - J	B - Z	Z - Z	G - F	
4.9	I - I	B - B	J - J	B - Z	Z - Z	G - F	
5.9	I - I	B - B	J - J	B - Z	Z - Z	G - F	
6.5	I - I	B - B	J - J	B - Z	Z - Z	G - F	
7.8	I - I	B - B	J - J	B - Z	Z - Z	G - F	
9.8	I - I	B - B	J - J	B - Z	Z - Z	G - F	

Table showing standard flange and thread combinations available in stock

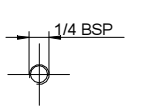
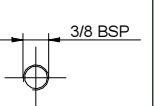
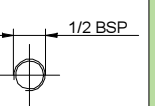
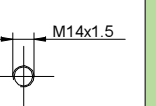
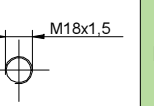
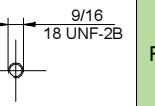
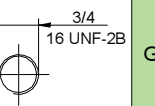
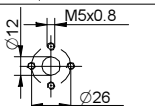
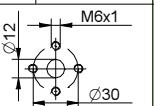
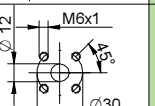
Body (threads/flanges)													
	A		B		C		D		E		F		G
	H		I		J	Closed Body	Z						