

# reversible motor - series XV

# XV-2M

STANDARD GERMAN MOTOR  
ø80 FLANGE - TAPER SHAFT

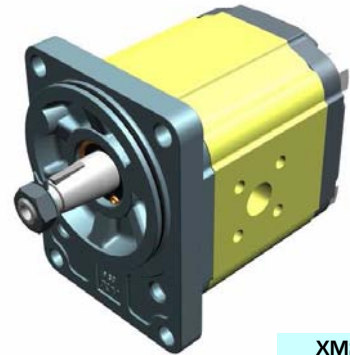

XM217

**X 2 M 51 25 F R R E**

Series	X	series XV
Group	2	group 2
Category	M	reversible motor
Displacement	51	17
Flange	25	Ø80 GERMAN STANDARDIZED reversible rotation (with OR)
Shaft	F	CO002 - Tapered 1:5 - ø17.4 - M12x1.5 - key thk.3
Body	IN	inlet - Ø35 a 45° Ø15 M6
	OUT	outlet - Ø35 a 45° Ø15 M6
Cover	E	with external drainage

Technical data table

TYPE	Displacement cm3/rev	Max. Pressure		CODE	
		P1 bar	P3 bar	External drainage	Internal drainage
XV-2M/04	4,20	260	300	X 2 M 41 25 F R R E	X 2 M 41 25 F R R F
XV-2M/06	6,00	260	300	X 2 M 43 25 F R R E	X 2 M 43 25 F R R F
XV-2M/09	8,40	260	300	X 2 M 45 25 F R R E	X 2 M 45 25 F R R F
XV-2M/11	10,80	260	300	X 2 M 47 25 F R R E	X 2 M 47 25 F R R F
XV-2M/14	14,40	250	290	X 2 M 49 25 F R R E	X 2 M 49 25 F R R F
XV-2M/17	16,80	230	270	X 2 M 51 25 F R R E	X 2 M 51 25 F R R F
XV-2M/19	19,20	210	250	X 2 M 53 25 F R R E	X 2 M 53 25 F R R F
XV-2M/22	22,80	200	240	X 2 M 55 25 F R R E	X 2 M 55 25 F R R F
XV-2M/26	26,20	170	210	X 2 M 57 25 F S S E	X 2 M 57 25 F S S F
XV-2M/30	30,00	160	200	X 2 M 59 25 F S S E	X 2 M 59 25 F S S F
XV-2M/34	34,20	150	190	X 2 M 61 25 F S S E	X 2 M 61 25 F S S F
XV-2M/40	39,60	140	180	X 2 M 63 25 F S S E	X 2 M 63 25 F S S F

P1) Max. working pressure - P3) Max. peak pressure

For heavy-duty applications, it is recommended to check the admissible torque of the shaft

Dimensions table

TYPE	Weight kg	A	B	C	D	E	F	D	E	F
		mm	mm	mm	IN			OUT		
XV-2M/04	2,330	89,7	41,1	79,7	ø15	35	M6x1	ø15	35	M6x1
XV-2M/06	2,430	92,7	41,1	82,7	ø15	35	M6x1	ø15	35	M6x1
XV-2M/09	2,530	96,7	43,1	86,7	ø15	35	M6x1	ø15	35	M6x1
XV-2M/11	2,630	100,7	47,5	90,7	ø15	35	M6x1	ø15	35	M6x1
XV-2M/14	2,730	106,7	47,5	96,7	ø15	35	M6x1	ø15	35	M6x1
XV-2M/17	2,830	110,7	47,5	100,7	ø15	35	M6x1	ø15	35	M6x1
XV-2M/19	2,930	114,7	47,5	104,7	ø15	35	M6x1	ø15	35	M6x1
XV-2M/22	3,180	120,7	55,0	110,7	ø15	35	M6x1	ø15	35	M6x1
XV-2M/26	3,280	124,7	55,0	114,7	ø20	40	M6x1	ø20	40	M6x1
XV-2M/30	3,530	132,7	63,2	122,7	ø20	40	M6x1	ø20	40	M6x1
XV-2M/34	3,730	139,7	63,2	129,7	ø20	40	M6x1	ø20	40	M6x1
XV-2M/40	3,930	148,7	63,2	138,7	ø20	40	M6x1	ø20	40	M6x1

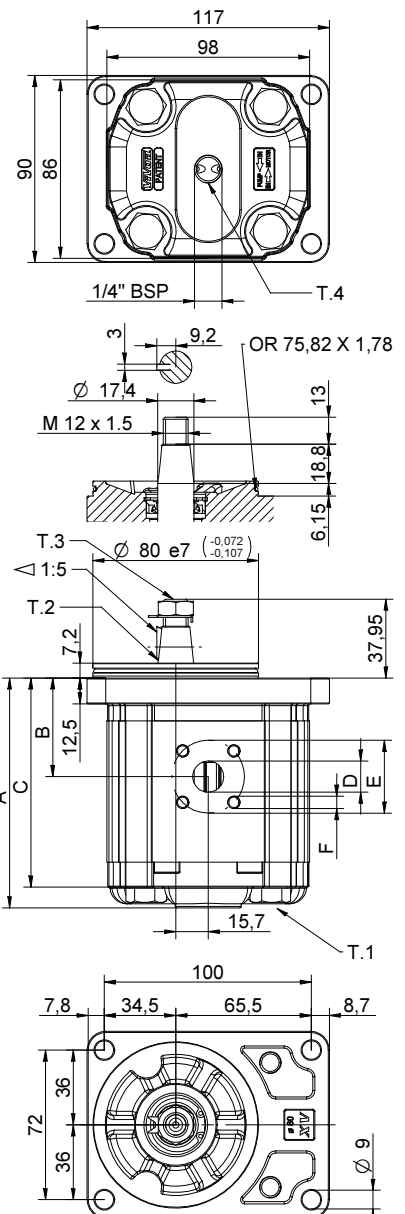

26/08/04 X2R5125FRRE.dft

T.1 = 54÷58.9 [Nm] - screw tightening torque M10

T.3 = 40 [Nm] - torque wrench setting 19

T.2 = 233.2 [Nm] - admissible shaft torque (N.B. When choosing a shaft, always check the admissible torque).

T.4 = 0.3÷0.5 bar - max. drainage pressure

# Table of variations

# XV-2M

## ø80 FLANGE

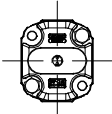
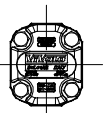
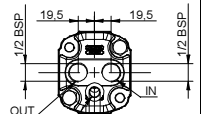
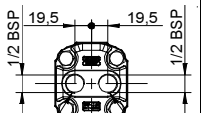
ø80 FLANGE		Shaft		Cover			
	25	CI001 - Parallel T.2 = 44.1 [Nm]	A	CI002 - Parallel T.2 = 67.5 [Nm]	B	 External drainage	E
		CO001 - Tapered T.2 = 233.2 [Nm]	E	CO002 - Tapered T.2 = 233.2 [Nm]	F	 Internal drainage	F
		SCF03 - Splined T.2 = 86.1 [Nm]	H			 IN + OUT + external	K
						 IN + OUT + internal	L

Displacement	
TYPE	CODE
XV-2M/04	41
XV-2M/06	43
XV-2M/09	45
XV-2M/11	47
XV-2M/14	49
XV-2M/17	51
XV-2M/19	53
XV-2M/22	55
XV-2M/26	57
XV-2M/30	59
XV-2M/34	61
XV-2M/40	63

Standard bodies					
Displacement cm3/rev	Standard threads				
	4	O - O	R - R	B - B	Z - Z
6	O - O	R - R	B - B	Z - Z	
9	O - O	R - R	B - B	Z - Z	
11	O - O	R - R	B - B	Z - Z	
14	P - P	R - R	C - C	Z - Z	
17	P - P	R - R	C - C	Z - Z	
19	P - P	R - R	C - C	Z - Z	
22	P - P	R - R	C - C	Z - Z	
26	Q - P	S - S	D - D	Z - Z	
30	Q - P	S - S	D - D	Z - Z	
34	Q - P	S - S	D - D	Z - Z	
40	Q - P	S - S	D - D	Z - Z	

Table showing standard flange and thread combinations available in stock

Body (threads/flanges)													
	A		B		C		D		E		F		G
	H		I		L		M		N			O	P
	Q		R		S		T		U			V	Z